

Good Practice Guide on Workers Health Protection through the Good Handling and Use of Crystalline Silica and Products Containing it



This document was issued by the signatories of the *Social Dialogue Agreement on Workers' Health Protection through the Good Handling and Use of Crystalline Silica and Products Containing it*, in the framework of art. 139 of the Treaty on European Union and with the support of the European Commission.

Good Practice Guide on Workers Health Protection through the Good Handling and Use of Crystalline Silica and Products containing it

Table of Contents

Preamble	2
Note to Users	3
Part 1: Respirable crystalline silica essentials	4
1. Introduction	4
1.1 What is silica?	4
1.2 Respirable crystalline silica	5
1.3 Occupational exposure to respirable crystalline silica	5
2. Silica and the silica industry	6
2.1 Where silica occurs	6
2.2 Activities involving use of crystalline silica containing materials	6
3. Respirable crystalline silica and its health effects	10
3.1 Respirable crystalline silica	10
3.2 Health effects of respirable crystalline silica	14
4. Risk Management – What do I need to do?	16
Bibliography	24
Glossary	25
Annex 1: Table of Occupational Exposure Limit Values	27
Annex 2: Tables of processes generating fine particles which could result in respirable crystalline silica exposure	28
Part 2: Task Manual	33
Task Guidance Sheets: Table of Contents	35

Good Practice Guide on Workers Health Protection through the Good Handling and Use of Crystalline Silica and Products containing it

Preamble

1. Why this guide

This guide is the result of an assembly of existing knowledge and information within sectors, which produce and/or use products or raw materials containing crystalline silica about the management of respirable crystalline silica. The publication of this guide is a contribution of the industry (employers and employees) towards the protection of workers from possible exposure to respirable crystalline silica in the workplace.

2. Objective of this Good Practice Guide

The objective of this guide is to give producers and users of products and materials that contain crystalline silica guidance on the practical application of a programme to manage respirable crystalline silica and guidance on the safe use of crystalline silica containing products in the workplace.

The silica producing and using industries stress that employees should be protected against potential health effects caused by occupational exposure to respirable crystalline silica in the workplace. Therefore efforts should be focused on minimising potential personal exposure to respirable crystalline silica in the workplace.

This is a dynamic guide, which concentrates on the aspects that are considered the most significant. Although comprehensive, it has not been possible to cover in detail all areas of concern. Users, customers, workers, and readers are advised to consult occupational health professionals and other experts concerning all matters regarding control of respirable crystalline silica in each specific workplace.

This Good Practice Guide is an Annex to the Agreement on Workers Health Protection Through the Good Handling and Use of Crystalline Silica and Products Containing it, based on certain principles: The Parties agree that crystalline silica and materials / products / raw materials containing crystalline silica are, as further described in Annex 5 hereto, basic, useful and often indispensable components / ingredients for a large number of industrial and other professional activities contributing to protecting jobs, and securing the economic future of the sectors and companies, and that their production and wide-range use should therefore continue

Note to users

This guide represents a summary of information collected from a number of sources, including existing documents providing information on the respirable crystalline silica issue, legal documents and expertise of people working in the industry.

In this short document it is not possible to cover all of the topics mentioned comprehensively, nor is it possible to cover in detail all areas of concern regarding respirable crystalline silica in the workplace. Users, customers, workers, and readers are advised to consult occupational health professionals and other experts concerning all matters regarding control of respirable crystalline silica in each specific workplace.

Part 1: Respirable crystalline silica essentials.

1. Introduction

Crystalline silica is an essential component of materials which have an abundance of uses in industry and are a vital component in many things used in our everyday lives. It is impossible to imagine houses without bricks, mortar or windows, cars without engines or windscreens, or life without roads or other transport infrastructures, and everyday items made of glass or pottery.

For many years, it has been known that the inhalation of fine dust containing a proportion of crystalline silica can cause lung damage (silicosis). In fact, silicosis is the world's oldest known occupational disease. However, the health risks associated with exposure to crystalline silica dust can be controlled and, by using appropriate measures, reduced or eliminated completely. It is just a matter of assessing the risk and taking appropriate action.

The first part of this Good Practice Guide is aimed primarily at employers. It is designed to help them decide whether the health of their employees, or others present in the workplace, is at risk from exposure to respirable crystalline silica. This booklet will guide them through the process of risk assessment and provide them with some general guidance on methods for controlling exposure to respirable crystalline silica in the workplace. It also stresses the importance of continual improvement.

At the end of Part 1, there is a glossary, which defines some of the more technical terms that are used in the document.

The second part of this guide is aimed at both employers and those who actually work with materials containing crystalline silica. It provides detailed guidance on methods for safe production, handling and use of these materials.

1.1 What is silica?

Silica is the name given to a group of minerals composed of silicon and oxygen, the two most abundant elements in the earth's crust. In spite of its simple chemical formula, SiO₂, silica exists in many different forms. Silica is found commonly in the crystalline state but occurs also in an amorphous (non-crystalline) state. Crystalline silica is hard, chemically inert and has a high melting point. These are prized qualities in various industrial uses.

This Good Practices Guide only covers three of the different forms of crystalline silica, i.e. the minerals quartz, cristobalite and tridymite. It does not cover amorphous silica, fused silica or other silicate minerals. Quartz, cristobalite and tridymite are often referred to as types of "free" crystalline silica because the crystalline silica is not chemically combined.

Quartz is by far the most common form of crystalline silica. It is the second most common mineral on the earth's surface and it is found in almost every type of rock i.e. igneous, metamorphic and sedimentary. Since it is so abundant, quartz is present in

nearly all mining operations. Irrespective of industrial activities, respirable crystalline silica is present in the environment.

Cristobalite and tridymite are not abundant in nature. However they are found in some igneous rocks. In industrial circumstances, cristobalite is also obtained when quartz is heated (to temperatures in excess of 1400°C), for example during the production and use of refractory materials. Cristobalite is also formed when amorphous silica or vitreous silica is heated at high temperature.

1.2 Respirable crystalline silica

Not all dust is the same! For any kind of dust, there are different particle sizes, often referred to as dust fractions. When dust is inhaled, its point of deposition within the human respiratory system is very much dependent upon the range of particle sizes present in the dust.

Three dust fractions are of main concern: the inhalable, thoracic and respirable dust fractions, which are defined in the European standard EN481. Information on this standard is given in section 3.1. In the case of crystalline silica, it is the respirable fraction of the dust that is of concern for its health effects.

Respirable dust can penetrate deep into the lungs. The body's natural defence mechanisms may eliminate much of the respirable dust inhaled. However, in case of prolonged exposure to excessive levels of this dust, it becomes difficult to clear the respirable dust from the lungs and an accumulation of dust can, in the long term, lead to irreversible health effects. Due to the fact that the health effects of crystalline silica are related to the respirable dust fraction, this Good Practices Guide will focus on the control of respirable crystalline silica.

1.3 Occupational exposure to respirable crystalline silica

Occupational exposure to respirable crystalline silica can occur in any workplace situation where airborne dust, containing a proportion of respirable crystalline silica, is generated.

Respirable dust particles are so small that they cannot be seen with the naked eye. Once airborne, respirable dust takes a very long time to settle. A single release of dust into the workplace air can lead to significant occupational exposure. In fact, in situations where the air is constantly stirred-up and where no fresh air is being introduced, respirable dust may remain airborne in the workplace for days.

Occupational exposure to respirable crystalline silica occurs in many industries including quarrying, mining, mineral processing (eg drying, grinding, bagging and handling), slate working, stone crushing and dressing, foundry work, brick and tile making, some refractory processes, construction work, including work with stone, concrete, brick and some insulation boards, tunnelling, building restoration and in the pottery and ceramic industries.

2. Silica and the silica industry

2.1 Where silica occurs

Crystalline silica, in the form of the mineral quartz, is found in many different materials – with sandstone being almost pure quartz. Other forms of silica occur but are of little importance occupationally. The table below gives an indication of typical levels of “free” crystalline silica in certain mineral sources, but it must be noted that these figures do vary.

Mineral sources	Percentage of crystalline silica
Ball clay	5 – 50%
Basalt	Up to 5%
Natural Diatomite	5-30%
Dolerite	Up to 15%
Flint	Greater than 90%
Granite	Up to 30%
Gritstone	Greater than 80%
Iron ores	7 – 15%
Limestone	Usually less than 1%
Quartzite	Greater than 95%
Sand	Greater than 90%
Sandstone	Greater than 90%
Shale	40 – 60%
Slate	Up to 40%

Source: HSE brochure, Control of respirable crystalline silica in quarries.

2.2 Activities involving use of crystalline silica containing materials.

Aggregates

Aggregates are a granular material used in construction. Nearly 3 billion tonnes of aggregates are produced and used in Europe annually. However, a majority of operators in the sector are small and medium sized enterprises. A typical small site provides direct employment for 7 to 10 persons. The aggregates industry consists of around 25,000 extraction sites across Europe, with 250,000 employees in the EU.

The most common natural aggregates are sand, gravel and crushed rock with a wide range of free silica content (from 0% to 100%). Subject to the individual risk assessments to be carried out under this Agreement, only the deposits with a high content of silica are relevant. But even in such cases, the risks of Respirable crystalline silica exposure for workers are normally low. Aggregates produced from rocks containing a small percentage of silica are, without prejudice to individual risk assessment, likely to be negligible in terms of their impact on worker’s health.

Ceramics industry

The ceramics industry uses silica principally as a structural ingredient of clay bodies and as a major constituent of ceramic glazes. The principal ceramic products containing silica include tableware and ornamental ware, sanitary ware, wall and floor tiles, bricks and roof tiles, refractories etc.

Around 2,000 companies produce ceramics in the EU. The number of employees in the EU ceramics industry is estimated at around 234,000. The ceramic industry is present in virtually all EU Member States.

Foundries

The foundry industry's products are ferrous, steel or non-ferrous metal castings produced by pouring molten metal into moulds which are typically, in total or in parts, made of bonded silica sand. The foundry industry is an important supplier to the automotive industry, mechanical engineering and other industries. It is a branch of mostly small and medium sized companies: roughly 4,000 foundries with 300,000 employees are situated in the EU Member States.

Glass Industry

Silicon dioxide is the principal glass forming oxide and thus silica sand is the major ingredient in all types of glass. The main glass products include packaging glass (bottles, jars etc.), flat glass (for buildings, mirrors, cars, etc.), domestic glass (tableware: drinking glasses, bowls; decoration, etc.), glass fibre (for reinforcement, insulation) and special glass (for tv, laboratory, optics etc.).

More than 1,000 companies produce glass in the EU. The glass industry is present in all European countries and employs more than 230,000 people in the EU.

After melting the raw material, there is no crystalline silica any more. Glass is an amorphous material.

Industrial Minerals and Metalliferous Minerals industries

Industrial Minerals:

A number of industrial minerals products are composed of silica. Silica is found commonly in the crystalline state but occurs also in an amorphous (non-crystalline) state. Crystalline silica is hard, chemically inert and has a high melting point. These are prized qualities in various industrial uses, mainly in the glass, foundry, construction, ceramic and chemicals industries. 145 million tons of industrial minerals (e.g. bentonite, borate, calcium carbonate, diatomite, feldspar, gypsum, kaolin & plastic clay, talc, etc) are extracted every year in Europe. Although not all do, industrial minerals may contain variable amounts of crystalline silica.

Those industrial minerals are produced by 300 companies or groups operating about 810 mines and quarries and 830 plants in 18 EU Member States, and in Switzerland, Norway, Turkey, Bulgaria, Romania and Croatia. The industrial minerals industry employs about 100,000 persons in the EU.

Metal ores:

A wide range of metal ores are extracted within the EU and for some, such as mercury, silver, lead, tungsten, zinc, chromium, copper, iron, gold, cobalt, bauxite, antimony, manganese, nickel, titanium, the EU is a relatively significant producer. In some cases, the European producers rank amongst the first ten producers in the world.

Metal ores are produced in 12 EU Member States as well as in Norway, Turkey, Bulgaria, Romania, Kosovo and Serbia. In the EU, this section of the mining and minerals industry employs directly about 23,000 people.

Although not all do, metal ores may contain variable amounts of crystalline silica.

Cement Industry

Cement is a powdered substance mainly used as the binding agent in the making of concrete. It is produced through several stages, basically made up of the two following essential phases:

- manufacture of a semi-finished product, so-called "clinker", obtained from the calcination in a high-temperature kiln (1 450°C) of a "raw mix" made up of a mixture of clay, limestone, and several other additives.

- manufacture of cement as a finished product, obtained by the homogeneous mixture of the ground clinker and calcium sulphate (gypsum) with or without - depending on the type of cement - one or more additional components: slag, fly ash, pozzolana, limestone, etc.

In 2004, the cement production of the current 25 Member States of the EU has reached 233 million tons, about 11% of the total world production (2,1 billion tons).

There are nearly 340 plants in the EU. Four of the five largest cement companies in the world are European. The cement industry employs about 55,000 persons in the EU.

Mineral Wool

Mineral wool has a unique range of properties, combining high thermal resistance with long-term stability. It is made from molten glass, stone or slag that is spun into a fibre-like structure which creates a combination of thermal, fire and acoustic properties, essential to the thermal and acoustic insulation as well as to the fire protection of domestic and commercial buildings or industrial facilities.

These properties derive from its structure, a mat of fibres which prevent the movement of air, and from its chemical composition.

Insulation manufacturers are developing to meet the growing environmental concerns of society, improving standards and regulations for the use of insulation materials.

Among mineral wools, only glass wool is of concern with regard to crystalline silica as glass wool is manufactured using sand, whilst stone wool is not. After melting the raw material for glass wool, there is no crystalline silica any more, as it becomes an amorphous material.

The mineral wool industry is present in all European countries and employs over 20,000 people across the EU.

Natural Stone Industry

Dimension stone exists in nature as an almost ready-made building material. Few realize, however, that it takes millions of years for this material to get to the point at which it can be easily produced and processed.

The industry consists only of small and medium sized companies of between 5 to 100 employees and is an essential supplier of the building industry. More than 40,000 companies exist in the EU, employing around 420,000 persons in the EU. Work with natural stones not only covers the production of stone in quarries, much more important is the processing of stones and the implementation of stones. Restoration and high-tech applications need qualified education and training which starts with stone workers up to high-tech stone engineers.

Mortar Industry

Mortar is defined as a mixture of aggregates, generally with a grain size of less than 4 mm (sometimes less than 8 mm, e.g. mortar for special decorative renders or floor screed mortar) and one or more binders and possibly additives and/or added mixtures.

Mortar with inorganic binders contains in addition water. The application and use of mortar is not limited to masonry constructions. The field of floor screed mortar is growing. There are many special kinds of mortar which are used for concrete repair, for tile fixing, for roofs, for the anchoring of bolts and for many other applications.

In addition the external thermal insulating composite systems (ETICS) are also a product of the mortar industry playing an important role in energy saving measures. More than 1,300 companies produce mortar in the EU. The EU mortar industry has more than 34,400 employees.

Precast Concrete Industry

Precast concrete is a factory-made building material widely used worldwide and available in all sizes and forms, from very small paving units to more than 50 meters long bridge elements.

Its production process consists in mixing cement, aggregates, water, additives and admixtures in different proportions, pouring them in moulds and let them harden. The products are supplied to the market in a dust-free hardened state. Dust generation can mainly occur in raw material handling and post-manufacturing mechanical treatments.

The industry is composed of small to medium-size enterprises, spread all over Europe. Estimated figures for the EU are: 10,000 production units, 250,000 workers and 300 to 400 million tons of products.

3. Respirable crystalline silica and its health effects

3.1 Respirable crystalline silica

When considering dust, three dust fractions are of main concern: the inhalable, thoracic and respirable dust fractions. However, for crystalline silica, the respirable dust fraction is the most important due to its potential health effects in humans.

It is also important to note that national occupational exposure limit values for crystalline silica apply to the respirable dust fraction. This dust fraction corresponds to the proportion of an airborne contaminant, which penetrates to the pulmonary alveolar (gas exchange) region of the lungs. This fraction normally represents 10 to 20% of the inhalable dust fraction, but the proportion can vary considerably.

The following diagram explains the difference between the various dust fractions:

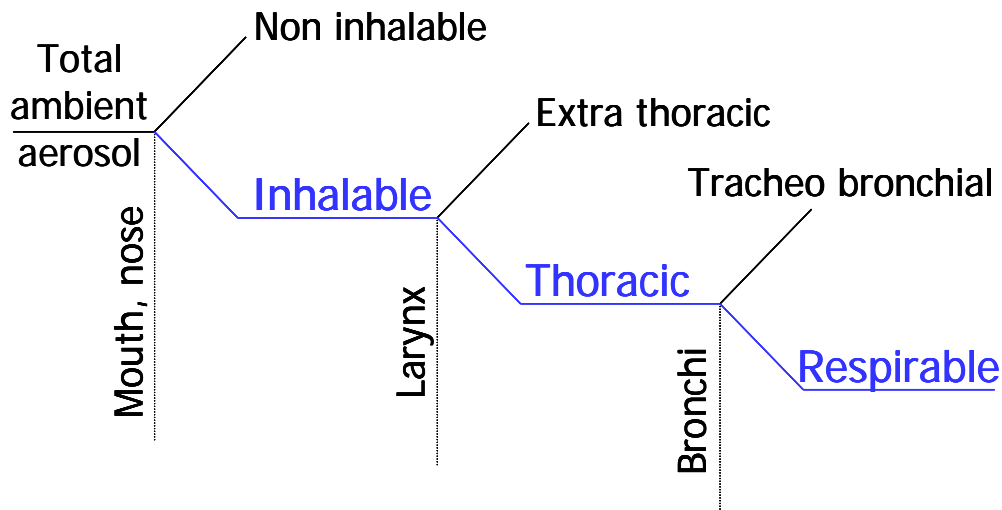

Source: Dichotomous model of aerosol fractionation according to Görner P. and Fabriès J.F.

The illustration overleaf identifies the different sections of the lung. The larynx (mentioned in the diagram above) lies between the pharynx (upper part of the airway) and the trachea (windpipe). The pulmonary alveolar region is made up of approximately 300 million alveoli, or air sacs.

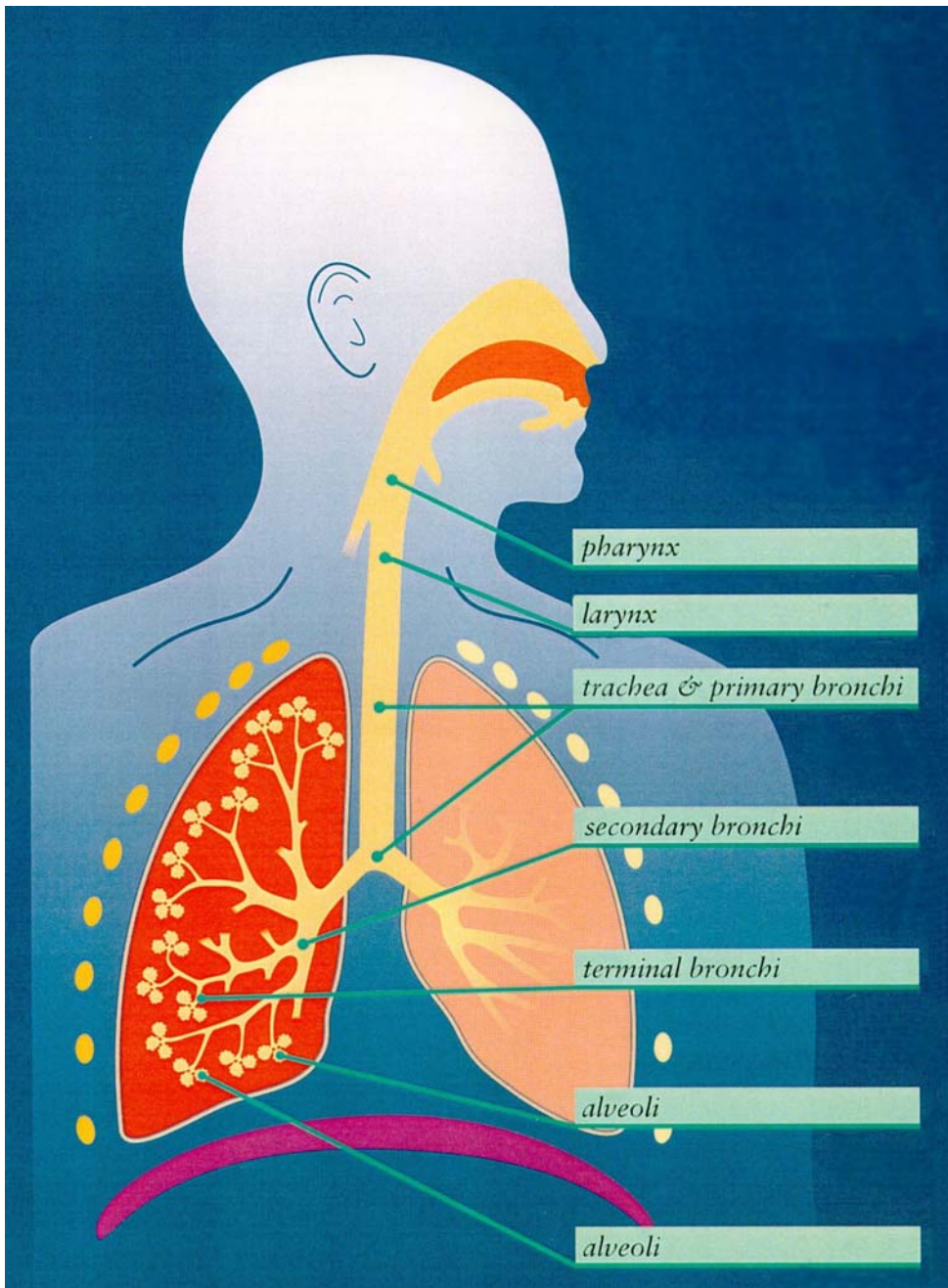
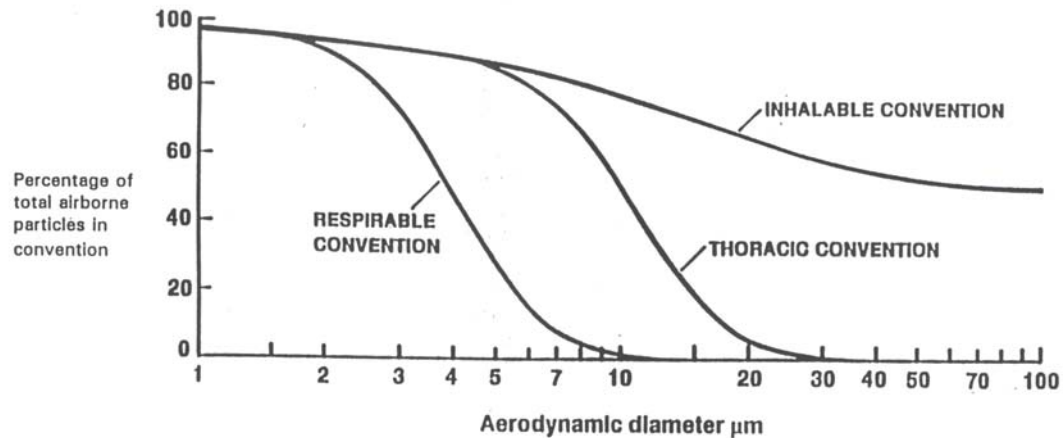

Diagram showing the different parts of the lung.

The European Standards Organisation (CEN) and the International Standards Organisation (ISO) have agreed standardised conventions for the health-related sampling of dusts or aerosols in workplaces (EN 481, ISO 7708).

These conventions represent target specifications for instruments used to assess the possible health effects due to inhalation of aerosols.

The following figure illustrates the sampling conventions:



The inhalable, thoracic and respirable conventions as percentages of total airborne particles, from EN 481.

The graph shows the probability that a particle of a specific aerodynamic diameter will penetrate the different parts of the human respiratory system.

For example, following the respirable convention, there is a 50% chance (or a probability of 0.5) that a particle of aerodynamic diameter 4 µm will penetrate the pulmonary alveolar region of the lung. Similarly, there is a 30% chance (probability of 0.3) that a particle of aerodynamic diameter 5 µm will penetrate this region of the lung.

The following table shows numerical values of the conventions in percentage terms.

As percentage of total airborne particles			
Aerodynamic Diameter µm	Inhalable Convention %	Thoracic Convention %	Respirable Convention %
0	100	100	100
1	97.1	97.1	97.1
2	94.3	94.3	91.4
3	91.7	91.7	73.9
4	89.3	89.0	50.0
5	87.0	85.4	30.0
6	84.9	80.5	16.8
7	82.9	74.2	9.0
8	80.9	66.6	4.8
9	79.1	58.3	2.5
10	77.4	50.0	1.3
11	75.8	42.1	0.7
12	74.3	34.9	0.4
13	72.9	28.6	0.2
14	71.6	23.2	0.2
15	70.3	18.7	0.1
16	69.1	15.0	0
18	67.0	9.5	
20	65.1	5.9	
25	61.2	1.8	
30	58.3	0.6	
35	56.1	0.2	
40	54.5	0.1	
50	52.5	0	
60	51.4		
80	50.4		
100	50.1		

Source: EN 481. Numerical values of the conventions, as percentages of total airborne particles

3.2 Health effects of respirable crystalline silica

People at work are rarely exposed to pure crystalline silica. The dust they breathe in at the workplace is usually composed of a mixture of crystalline silica and other materials.

The response of an individual is likely to depend on:

- the nature (e.g. particle size and surface chemistry) and crystalline silica content of the dust
- the dust fraction
- the extent and nature of personal exposure (duration, frequency and intensity, which may be influenced by the working methods)
- personal physiological characteristics
- smoking habits

Silicosis

Silicosis is a commonly known health hazard, which has been associated historically with the inhalation of silica-containing dust (Fubini 1998).

Silicosis is one of the most common types of pneumoconiosis. It is a nodular progressive fibrosis caused by the deposition in the lungs of fine respirable particles of crystalline silica. The resulting scarring of the innermost parts of the lungs can lead to breathing difficulties and, in some cases, death. Larger (non-respirable) particles are more likely to settle in the main airways of the respiratory system and may be cleared by mucus action (HSE 1998).

Silicosis is one of the world's oldest known occupational diseases and is caused by the inhalation of respirable crystalline silica (Stacey P. 2005).

Silicosis can vary greatly in its severity, from "simple silicosis" to "progressive massive fibrosis". Generally, three types of silicosis are described in literature (EUR 14768; INRS 1997):

- Acute silicosis occurs as a result of extremely high exposure to respirable crystalline silica over a relatively short period of time (within 5 years). The condition causes rapidly progressive breathlessness and death, usually within months of onset
- Accelerated silicosis can develop within 5 to 10 years of exposure to high levels of respirable crystalline silica
- Chronic silicosis is often described as the result of exposure to lower levels of respirable crystalline silica, occurring over longer periods of time (exposure duration greater than 10 years)

Future cases of silicosis can be reduced by implementing appropriate measures to reduce exposure to silica-containing dusts. Such measures include improved work practices, engineering controls, respiratory protective equipment and training programmes.

Silica and cancer risk

In 1997, a working group of the International Agency for Research on Cancer (IARC), which has no regulatory power in the European Union but which is an authority in the field of Cancer Research, concluded on the basis of literature review that inhaled respirable crystalline silica from occupational sources is carcinogenic to humans.

In making this evaluation, the IARC working group noted also that carcinogenicity was not detected in all industrial circumstances studied and may be dependent on inherent characteristics of the crystalline silica or on external factors affecting its biological activity.

A recommendation (SUM DOC 94 final) from the EU Scientific Committee for Occupational Exposure Limits (SCOEL) was adopted in June 2003. The main conclusions were as follows:

The main effect in humans of the inhalation of respirable silica dust is silicosis. There is sufficient information to conclude that the relative lung cancer risk is increased in persons with silicosis (and, apparently, not in employees without silicosis exposed to silica dust in quarries and in the ceramic industry). Therefore preventing the onset of silicosis will also reduce the cancer risk. Since a clear threshold for silicosis development cannot be identified, any reduction of exposure will reduce the risk of silicosis.

Other health effects

In scientific literature, papers are published about the possible association between silica exposure and scleroderma (an autoimmune disorder) and increased risk of kidney disease. Further information on this can be found in specialised literature on the relationship between silica exposure and health effects (Fubini 1998).

4. Risk Management – What do I need to do?

The aim of this section is to provide advice to the reader on when and how to apply the advice given in this Good Practice Guide to their specific circumstances.

Using a simple question and answer format, it will introduce basic risk management techniques that should be applied to workplace situations where persons may be exposed to respirable crystalline silica.

The advice given on the following pages will help the reader to decide to what extent this Good Practice Guide applies to their circumstances.

Guidance will be given on:

Assessment	How to assess whether there is a significant risk from exposure to respirable crystalline silica.
Control	How to decide what type of control and prevention measures should be put in place to treat the risks that are identified - ie to eliminate them, or to reduce them to an acceptable level.
Monitoring	How to monitor the effectiveness of the control measures in place. How to monitor workers' health.
Education	What information, instruction and training should be provided to the workforce in order to educate them about the risks to which they may be exposed.

The risk management processes of **Assessment, Control, Monitoring and Education** make up the foundation of all European health and safety legislation.

Question 1: How do I determine whether people are exposed to respirable crystalline silica in my workplace?

Answer: Respirable crystalline silica enters the body when dust containing a proportion of crystalline silica is inhaled. When the particle size range of the dust is sufficiently small (such that the particles fall within the respirable fraction), the dust will travel deep into the lungs. It is at this point that respirable crystalline silica can cause health effects. Occupational exposure to respirable crystalline silica can occur in any workplace situation where airborne dust is generated, which contains a proportion of respirable crystalline silica. Occupational exposure to respirable crystalline silica occurs in many industries.

Use the simple flow chart below to carry out an initial assessment to determine whether there is any significant risk of exposure to respirable crystalline silica. The possible presence of fine particles of crystalline silica means that there may be a risk. If there is no foreseeable risk, then you don't need to take any specific measures. However, you should always obey the general principles of prevention.

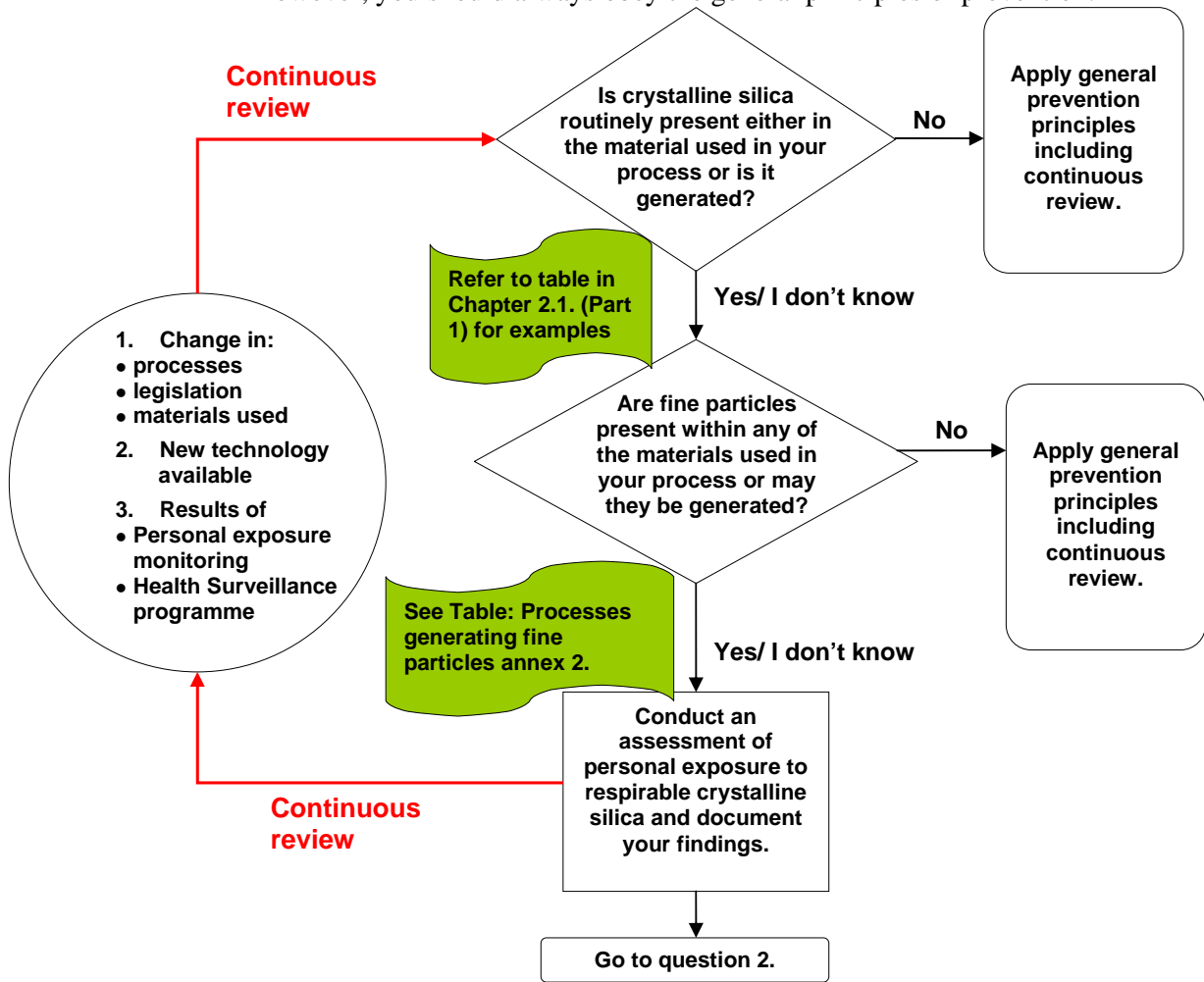

Figure: Initial assessment procedure.

The following table, taken from the Mining/Quarrying industry, is an example and may be helpful when assessing whether the processes in your specific workplace may cause the generation of fine particles which, if airborne, could lead to personal exposure to respirable crystalline silica.

Table: Processes generating fine particles which could result in respirable crystalline silica exposure:

MINE/QUARRY PROCESS	Where may fine particles be generated? (Non exhaustive list)
EXTRACTION (Mining and quarrying)	<ul style="list-style-type: none"> • Wind blown dust • Blasting • Ripping / bulldozing • Vehicle movements • Conveyor transport • Loading and unloading • Drilling
CRUSHING and MILLING	<ul style="list-style-type: none"> • All dry processes • Low risk in wet milling process
WASHING CHEMICAL TREATMENT SEPARATION	Low risk of airborne dust generation
DRYING AND CALCINING	All drying and calcining processes
DRY SCREENING DRY GRINDING	<ul style="list-style-type: none"> • All dry screening processes • All dry grinding processes
PACKAGING	<ul style="list-style-type: none"> • Bagging • Palletising • Vehicle Movements
STOCKPILING	<ul style="list-style-type: none"> • Wind blown dust from stockpiles • Vehicle Movements around stockpiles
LOADING and TRANSPORT	<ul style="list-style-type: none"> • Vehicle loading (free-fall of materials) • Vehicle movement • Conveyor transport
MAINTENANCE	Activities requiring dismantling/opening/access to equipment, or entry into dusty process areas listed above.
CLEANING	Cleaning activities involving entry into dusty process areas listed above and/or done using a dry brush or compressed air.

Other examples are given in annex 2.

Question 2: How do I conduct an assessment of personal exposure to respirable crystalline silica?

Answer: Use the simple flow chart below to help you to carry out your assessment of personal exposure levels. It's a good idea at this stage to make detailed notes of the dust control measures that are already in place in your workplace. You will need this information later, in order to assess whether you are complying with the general principles of prevention.

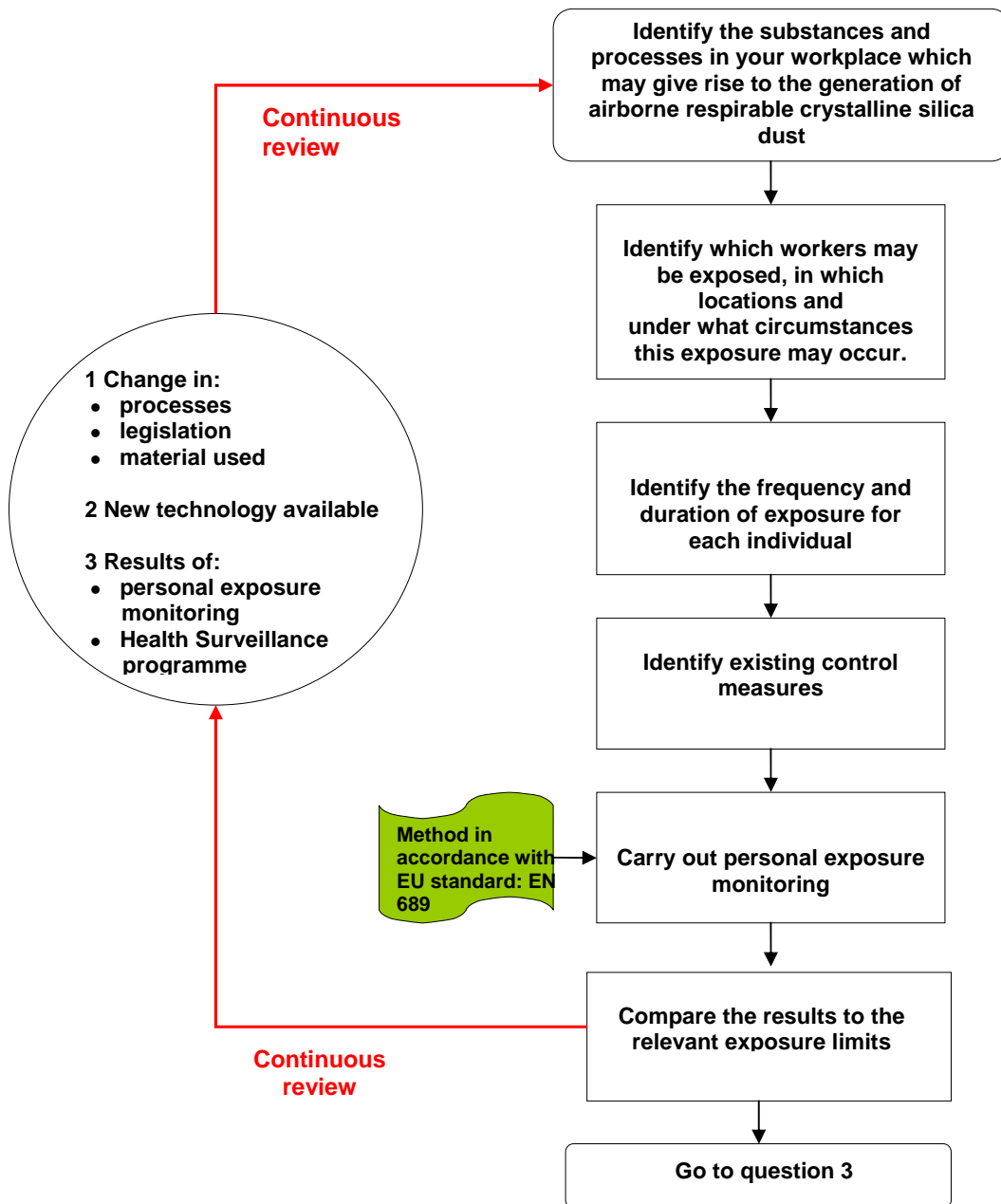

Figure: Assessment of personal exposure levels to respirable crystalline silica.

Personal Exposure Monitoring

The only way to quantify the amount of respirable crystalline silica present in the workplace atmosphere is to perform sampling of the air and analysis of the dust collected. Occupational exposure assessment is the process of measuring or estimating the intensity, frequency and duration of human contact with such contaminants.

There are two types of measurements commonly used:

- Personal;
- Static.

Both types of measurement can be used jointly as they are complementary.

It is up to the experts designated by the employers and the employees' representatives to opt for the most adequate solutions, while respecting the national and European provisions.

General requirements for dust monitoring (taken from the European Standards EN 689 and EN 1232) are provided in the "Dust Monitoring Protocol", **Annex 2** of the *Agreement on Workers Health Protection through the Good Handling and Use of Crystalline Silica and Products Containing it*. Producers and end users of products and raw materials containing crystalline silica are encouraged to adopt this protocol.

Advice on organising a dust-monitoring programme can be sought from a competent occupational hygienist.

Occupational Exposure Limits

An occupational exposure limit value represents the maximum time-weighted average concentration of an airborne contaminant to which a worker can be exposed, measured in relation to a specified reference period, normally eight hours.

Currently there are many different types of occupational exposure limit value, defined by individual Member States of the European Union (see annex). These limits are all different and, in addition, cannot be compared directly.

There is currently no European Union occupational exposure limit for respirable crystalline silica.

Question 3: I have done my exposure assessment, but I'm not sure how to interpret the results. What do I need to do now?

Answer: You need to compare the results of your assessment against the occupational exposure limit for respirable crystalline silica that applies in your country and you need to check that you are complying with the general principles of prevention.

It may be necessary for you to implement additional control measures (following the general principles of prevention) to eliminate, or reduce, exposure to respirable crystalline silica so that you meet the relevant occupational exposure limit.

In any case, you will need to provide training to your workforce on the risks to their health, which may arise from exposure to respirable crystalline silica and how to use the control measures provided.

The following flow chart will guide you through the process.

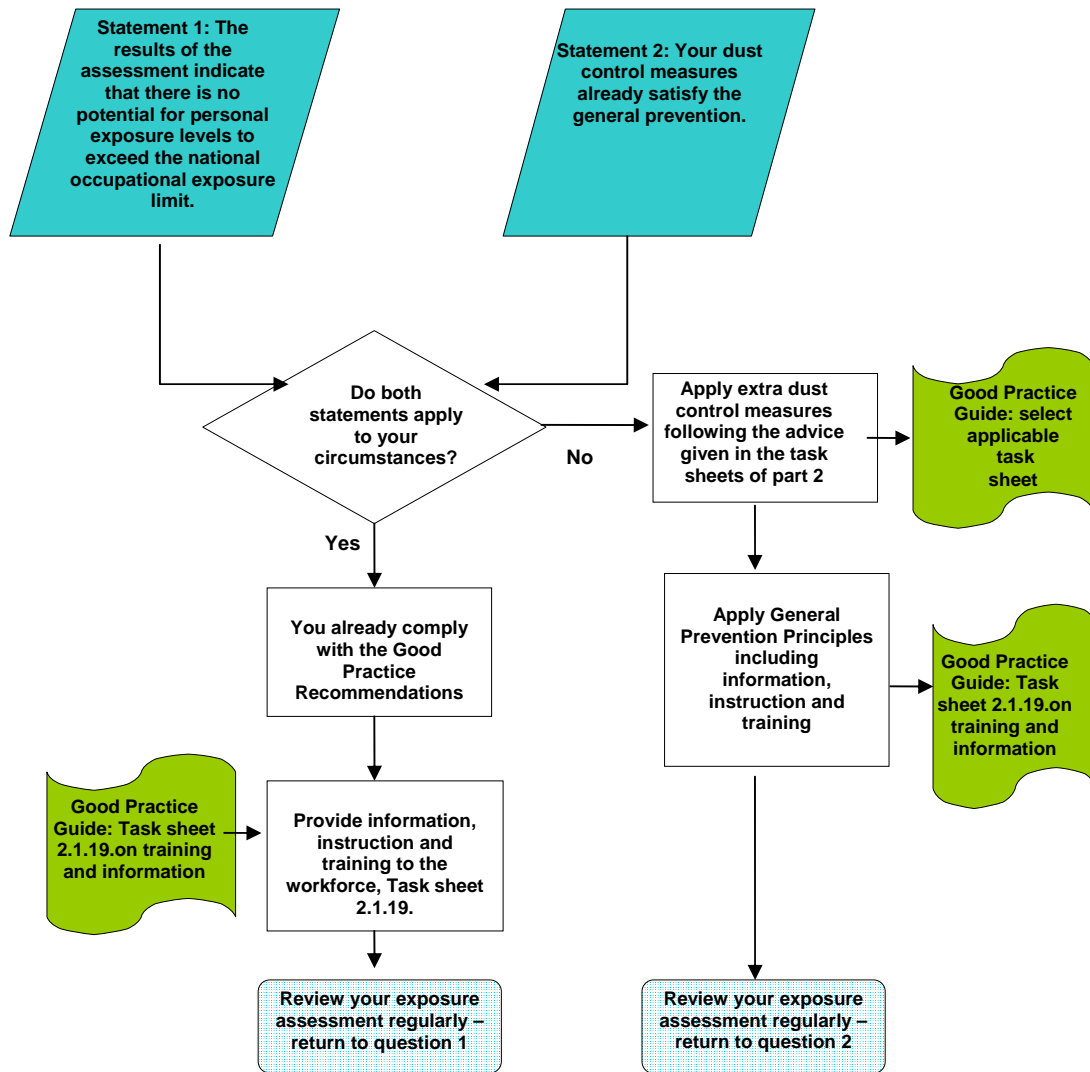

Figure: Simple decision flow chart for control of exposure to respirable crystalline silica.

General prevention principles

In the development of this Good Practices guide, the authors respected the prevention strategy, which is described in Council Directive 89/391/EEC and in its transposition in the national laws.

Nine prevention principles are described and one must consider the following hierarchy in the preventive measures to be taken:

- avoiding risks
- evaluating the risks which cannot be avoided
- combating the risks at source
- adapting the work to the individual
- adapting to technical progress
- replacing the dangerous by the non dangerous or the less dangerous
- developing a coherent overall prevention policy (including the provision of health surveillance of workers)
- giving collective protective measures priority over individual protective measures
- giving appropriate information, instruction and training to the workers

In the context where crystalline silica is handled in the workplace, examples of practical applications of the above principles are:

- **Substitution:** taking into account economic, technical and scientific criteria, replace a dust-generating process with a process generating less dust (e.g. use of a wet process instead of a dry process, or an automated process instead of a manual process).
- **Provision of engineering controls:** de-dusting systems (dust suppression¹, collection² and containment³) and isolation techniques⁴.
- **Good housekeeping practices.**
- **Work pattern:** establish safe working procedures, job rotation.
- **Personal protective equipment:** provide protective clothing and respiratory protective equipment.
- **Education:** provide adequate health and safety training to the workers, information and instructions specific to their workstation or job.

Compliance with Member State Occupational Exposure Limits is just one part of the Risk Management process. You should additionally always ensure that you comply with the General Principles of Prevention, as defined in Council Directive 89/391/EEC.

¹ e.g. water, steam, mist or fog sprays.

² e.g. cyclones, scrubbers, bag filters, electrostatic precipitators and vacuum cleaners.

³ e.g. encapsulation

⁴ e.g. control room with a clean air supply

Training for the Workers

One of the task sheets in Part 2 of this guide gives detailed guidance on the format and content of training, which should be provided to workers to inform them of the risks to their health that may arise from the handling and use of substances containing crystalline silica.

Risk Management - Summary

The following diagram summarises the risk management process, from the perspective of both employer and employee, when applied to control of respirable crystalline silica.

The health and safety systems implemented in the companies must be respected by both employer and employee.

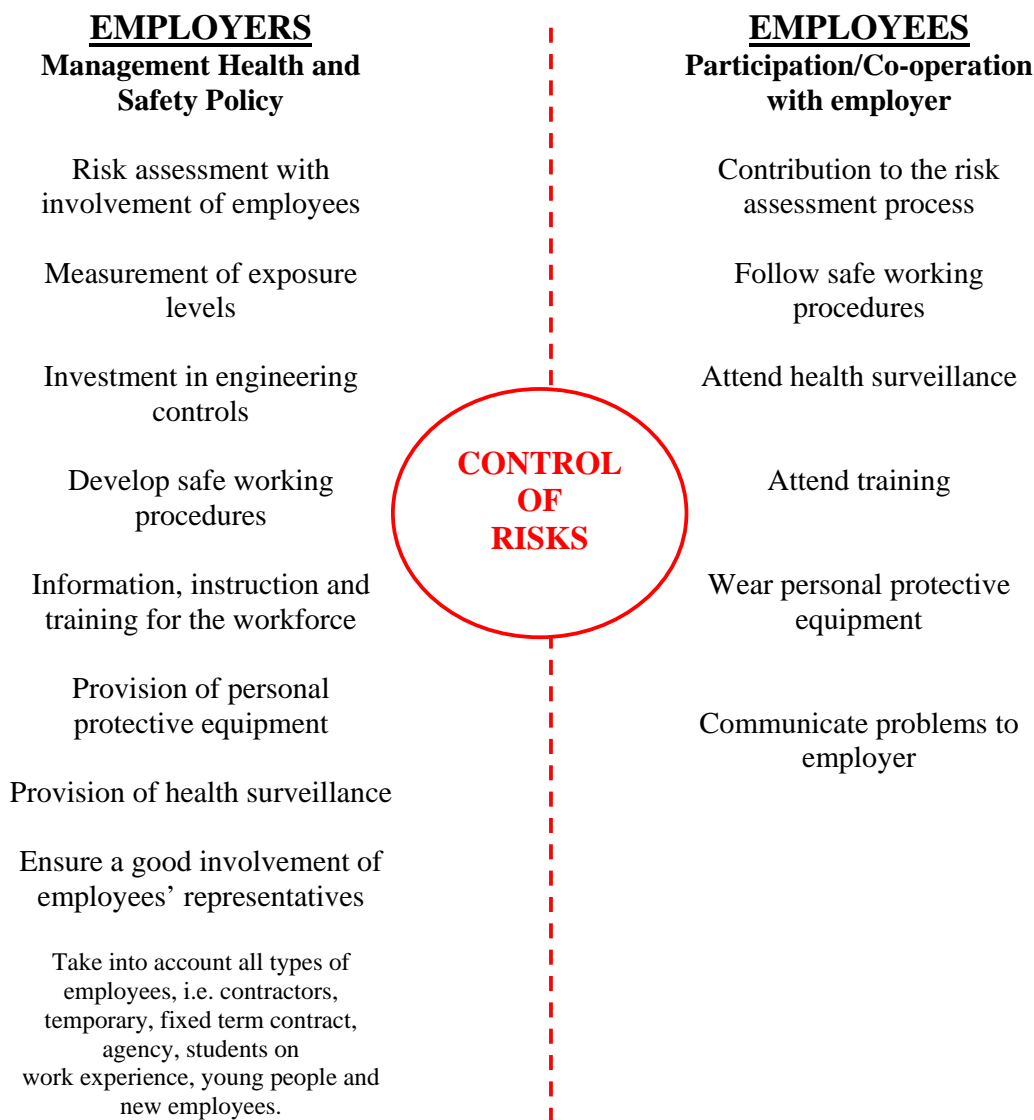

Bibliography

Brodtkom F. (Dr.), Good Environmental Practice in the European Extractive Industry: A reference guide. 2001.

Coope Brian, A socio-economic review of crystalline silica usage. September 1997.

Council Directive 89/391/EEC of 12 June 1989 on the introduction of measures to encourage improvements in the safety and health of workers at work.

Council Directive 89/686/EEC of 21 December 1989 on the approximation of the laws of the Member States relating to personal protective equipment

Council Directive 98/24/EC of 7 April 1998 on the protection of the health and safety of workers from the risks related to chemical agents at work (fourteenth individual Directive within the meaning of Article 16(1) of Directive 89/391/EEC).

CEN (Comité Européen de Normalisation), EN 481 Workplace atmospheres - Size fraction definitions for measurement of airborne particles. 1993, CEN.

CEN (Comité Européen de Normalisation), EN 689 Workplace atmospheres-Guidance for the assessment of exposure by inhalation to chemical agents for comparison with limit values and measurement strategy. 1995, CEN.

Health & Safety at work, Information notices on diagnosis of occupational diseases, European Commission, Employment & social affairs, Report EUR 14768.

Fubini B., Health effects of silica in *The Surface properties of silica*, John Wiley & Sons Ltd, 1998.

Görner P. and Fabriès J. F., Industrial aerosol measurement according to the new sampling conventions. *Occupational Hygiene*, 1996. 3(6): p. 361-376.

HSE (Health and Safety Executive), Control of respirable crystalline silica in quarries. 1992, HSE.

HSE (Health and Safety Executive), Guidance note EH 59 – Respirable crystalline silica. 1998, HSE.

INRS (Institut National de Recherche et de Sécurité), Fiche toxicologique 232 – Silice cristalline. 1997, INRS.

IARC (International Agency for Research on Cancer), IARC Monographs on the Evaluation of Carcinogenic Risks to Humans. Silica, Some Silicates, Coal Dust and para-Aramid Fibrils. 1997, Librairie Arnette: Paris.

ISO (International Standardization Organization), ISO 7708 Air quality – Particle size fraction definitions for health-related sampling. 1995, ISO.

ISO EC guide 73 : Risk management – Vocabulary- Guidance for use in Standards

Glossary

Aerodynamic diameter: diameter of a sphere of density 1g.cm^{-3} with the same terminal falling velocity in the air, related to the particle in question, in the same conditions of temperature, pressure and relative humidity.

Bagging: a process during which products are put into bags (manually or automatically).

Control measures: measures carried out in order to reduce personal exposures of a workplace contaminant to an acceptable level.

Crushing: a process during which coarse material is broken down (crushed) into smaller fragments.

Dust: a dispersed distribution of solids in air, brought about by mechanical processes or stirred up.

Epidemiology: the study of the distribution and causes of health-related conditions and events in populations and the application of this study to control health problems.

Exposure: inhaled exposure results from the presence of an airborne contaminant in the air within the breathing zone of a worker. It is described in terms of the concentration of the contaminant, as derived from exposure measurements and referred to the same reference period as that used for the occupational exposure limit value.

Exposure assessment: the process of measuring or estimating the intensity, frequency and duration of human contact with airborne contaminants which may be present in the working environment.

Grinding: the minerals production process in which individual mineral grains are broken down to a required particle size, typically to a fine flour. The process is sometimes also referred to as “milling” since it is carried out inside a grinding mill.

Hazard: an intrinsic property of a substance with the potential to cause harm.

Health surveillance: the assessment of an individual worker to determine the state of health of that individual.

HSE: The United Kingdom Health and Safety Executive.

IARC: International Agency for Research on Cancer.

Inhalable dust (also referred to as Total inhalable dust): the fraction of an airborne material which enters the nose and mouth during breathing and which is therefore available for deposition anywhere in the respiratory tract (MDHS 14/2). The standard EN 481 gives the percentage of the suspended total particulate that can be inhaled according to particle size.

INRS: Institut National de Recherche et de Sécurité.

ISO: International Standardisation Organisation.

Measurement: a process carried out in order to determine the airborne concentration of a substance in the workplace environment.

Measurement procedure: a procedure for sampling and analysing one or more contaminants in workplace air.

Milling: the minerals production process in which the lumps of mineral are broken down to individual grains. See also “grinding”.

Occupational exposure limit value: the maximum admissible exposure of a worker to an airborne contaminant that is present in the air in the workplace. It represents the maximum time-weighted average concentration of an airborne contaminant to which a worker can be exposed, measured in relation to a specified reference period, normally eight hours.

Personal protective equipment: equipment designed to be worn or otherwise held by the worker to protect him against one or more hazards likely to endanger his safety and health at work, or any addition or accessory designed to meet this objective.

Personal sampler (or personal sampling device): a device worn by a person that samples the air in that person’s breathing zone, in order to determine his personal exposure to airborne contaminants.

Pulmonary alveolar region: the gas exchange region of the lung, made up of approximately 300 million alveoli, or air sacs.

Prevention: the process of eliminating or reducing occupational health and safety risks.

Respirable dust fraction: fraction of an airborne material that penetrates to the gas exchange region of the lung.

Risk: likelihood that the potential for harm will be realised under the conditions of use and/or exposure.

Standard: Document elaborated by consensus and agreed by an approved organisation with standardisation activities. This document gives, for common and repeated practices, rules and guidelines on how an activity should be conducted.

Static sampler: sampling device positioned at a fixed point in the workplace for the duration of a measurement (as opposed to being worn by a person).

Thoracic dust fraction: fraction of an airborne material that penetrates beyond the larynx.

Workplace: the whole area intended to house workstations and accommodation, where provided, to which workers have access in the context of their work.

Annex 1: Table of Occupational Exposure Limit values (in mg/m³) – January 2006 (to be extended to EU 25)

The following table shows the Occupational Exposure Limits (OEL) for quartz, cristobalite and tridymite in application in European countries. As soon as new occupational exposure limits (in mg/m³) appear in a country, they will implicitly be integrated in this document.

	OEL Name	Adopted by	Quartz	Cristobalite (c)	Tridymite
Austria	Maximale ArbeitsplatzKonzentration	Bundesministerium für Arbeit und Soziales	0.15	0.15	0.15
Belgium		Ministère de l'Emploi et du Travail	0.1	0.05	0.05
Denmark	Threshold Limit Value	Direktoratet for Arbejdstilsynet	0.1	0.05	0.05
Finland	Occupational Exposure Standard	National Board of Labour Protection	0.2	0.1	0.1
France	Empoussiérage de référence	Ministère de l'Industrie (RGIE)	5 or 25k/Q		
	Valeur limite de Moyenne d'Exposition	Ministère du Travail	0.1	0.05	0.05
Germany	Grenzwert nach TRGS 900	Bundesministerium für Arbeit	- ⁵	-	-
Greece		Legislation for mining activities	0.1 ⁶	0.05	0.05
Ireland		2002 Code of Practice for the Safety, Health & Welfare at Work (CoP)	0.05	0.05	0.05
Italy	Threshold Limit Value	Associazione Italiana Degli Igienisti Industriali	0.05	0.05	0.05
Luxembourg	Grenzwert nach TRGS 900	Bundesministerium für Arbeit	0.15	0.15	0.15
Netherlands	Maximaal Aanvarde Concentratie	Ministerie van Sociale Zaken en Werkgelegenheid	0.075	0.075	0.075
Norway	Administrative Normer (8hTWA) for Forurensing I Arbeidsmiljøet	Direktoratet for Arbejdstilsynet	0.1	0.05	0.05
Portugal	Threshold Limit Value	Instituto Portuges da Qualidade, Hygiene & Safety at Workplace	0.1	0.05	0.05
Spain	Valores Limites	1) Instituto Nacional de Seguridad e Higiene	0.1	0.05	0.05
		2) Reglamento General de Normas Basicas de Seguridad Minera	5 or 25k/Q		
		2.1) New proposal (except coal mining)	0.1	0.05	0.05
Sweden	Yrkeshygieniska Gränsvärden	National Board of Occupational Safety and Health	0.1	0.05	0.05
Switzerland	Valeur limite de Moyenne d'Exposition		0.15	0.15	0.15
United Kingdom	Workplace Exposure Limit	Health & Safety Executive	0.3 ⁷	0.3	0.3

Q : quartz percentage

K: noxious coefficient (equal to 1)

Source : Adapted from IMA-Europe, Date : 07/01/04, updated version available at <http://www.ima-eu.org/en/silhsefacts.html>

OELs are applicable to 100 % quartz, cristobalite or tridymite. Some countries have special rules for mixed dust, e.g. in France the following equation is applied: $C_{ns}/5 + C_q/0.1 + C_c/0.05 + C_t/0.05 \leq 1$ (C = mean concentration, ns = non silica content, q = quartz content, c = cristobalite content, t = tridymite content) where all variables are in mg/m³.

⁵ In Germany there are no OELs for crystalline silica since 2005; instead of an OEL there is a workers health protection system.

⁶ According to Mining Legislation Code and the Presidential Degree 307/1986, the occupational exposure limit value to respirable crystalline silica is calculated according to the following formula: $OEL = 10 / (\%Q + 2)$ where Q= % concentration of free crystalline silica in the respirable fraction of the dust

⁷ In the United Kingdom an Exposure Limit 0.1 mg/m³ is expected.

Annex 2

Tables of processes generating fine particles which could result in respirable crystalline silica exposure

1. **Processes generating fine particles which could result in respirable crystalline silica exposure in the cement production:**

The level of RCS may depend on the type of materials used.

The risk of presence of respirable crystalline silica (RSC) is low and is limited to the first phases of the cement production process (extraction/quarrying; transport of raw materials, grinding/crushing, raw mill). In and after the kiln system, the risk is negligible.

Cement Production	Where may RCS be formed?
Extraction/quarrying	Wind blown dust Blasting Ripping bulldozing
Transport of raw materials	Vehicle movements (mostly closed systems) Conveyor transport (mostly closed systems) Loading and unloading (mostly closed systems)
Grinding/crushing	Raw material processing: clay, sand, limestone, diatomaceous earth
Raw meal	Blown dust (mostly closed systems) Maintenance (mostly closed systems)
Blending, storage and transport raw meal	-
Kiln	-
Transport and storage	-
Cement mill	-
Packaging	Bagging Palletising
Transport	Vehicle loading Vehicle movement
Maintenance	Activities requiring dismantling/opening/access to equipment, or entry into dusty process areas listed above, including filters Risk is strongly linked to the type of materials (i.e. step in production process)
Cleaning	Cleaning activities involving entry into dusty process areas listed above

2. Processes generating fine particles which could result in respirable crystalline silica exposure in the glass and mineral wool industries:

Glass Manufacturing	Where can fine crystalline silica particles be produced ?
Raw Material Storage	When no silo storage <ul style="list-style-type: none"> - wind dispersion - loading / unloading - transporting (conveyor belt)
Batch Preparation	<ul style="list-style-type: none"> - mixing - conveying - cleaning
Loading and Transport	<ul style="list-style-type: none"> - batch ingredients
Batch Charge	<ul style="list-style-type: none"> - manual charge of batch - automated charge of batch
Filter Installation	<ul style="list-style-type: none"> - operating - cleaning - maintenance - repair
Cleaning Operations	<ul style="list-style-type: none"> - batch conveyor installation - furnace parts
Repair and Dismantling Operations	<ul style="list-style-type: none"> - batch conveyor installation - furnace parts

3. Processes generating fine particles which could result in respirable crystalline silica exposure in the ceramics industry:

CERAMICS (*) PROCESS	Where may fine particles be generated? (Non exhaustive list)
Supply, Unloading, Transport, Storage	<ul style="list-style-type: none"> • Vehicle movement • Vehicle unloading / Bulk unloading • Bulk road tanker unloading (blowing off) • Bag emptying • Conveyor transport • Other transport systems
Raw material's preparation for body and Glaze	<ul style="list-style-type: none"> • Proportioning • Mixing of materials • Grinding / Milling • Screening • Dewatering (Spray drying) <p>Low risk in wet processes:</p> <ul style="list-style-type: none"> • Wet milling • Plastification • Resolving
Shaping	<ul style="list-style-type: none"> • Dry pressing • Isostatic pressing • Green shaping by machining • Dressing of casted parts • Garnishing <p>Low risk in wet processes:</p> <ul style="list-style-type: none"> • Mould making • Slip casting • Plastic shaping
Drying	<ul style="list-style-type: none"> • Periodic and continuous drying
Glazing	<ul style="list-style-type: none"> • Spray glazing <p>Low risk in wet processes:</p> <ul style="list-style-type: none"> • Glazing by dipping • Glazing by watering • Decoration
Firing	<ul style="list-style-type: none"> • Firing (Biscuit-, final-, decoration-, ...)
Subsequent treatment	<ul style="list-style-type: none"> • Grinding • Polishing • Cutting / sawing • Drilling <p>Low risk of airborne dust generation:</p> <ul style="list-style-type: none"> • Sorting • Packaging

CERAMICS (*) PROCESS	Where may fine particles be generated? (Non exhaustive list)
Maintenance	<ul style="list-style-type: none"> • Cutting Refractory Materials (for kilns) • Removing dust or sludge from an extraction unit
Cleaning	<ul style="list-style-type: none"> • Dry cleaning <p>Low risk of airborne dust generation:</p> <ul style="list-style-type: none"> • wet cleaning

(*) not every process step is necessary for every ceramic product

4. Processes generating fine particles which could result in respirable crystalline silica exposure in the foundry industry:

Casting Production	Where may fine particles be generated ?
<u>Sand transport and storage</u>	<u>Pneumatic conveying</u>
<u>Sand preparation</u>	<u>Mixing</u> <u>Transport</u>
<u>Core making and Moulding</u>	<u>Mixing</u> <u>Transport</u>
<u>Melting shop</u>	<u>Lining and break-out of refractory material (ladles, furnaces)</u>
<u>Knockout</u>	<u>Separating castings from sand</u>
<u>Fettling shop</u>	<u>Shot-blasting</u> <u>Grinding of castings</u>

5. Processes generating fine particles which could result in respirable crystalline silica exposure in the precast concrete industry:

Precast Concrete manufacturing	Where can fine crystalline silica particles be produced ?
RAW MATERIALS (Supply, unloading, transport and storage)	General storage (indoor and outdoor) Handling and transportation systems Bag emptying Bulk loading/unloading Crushing/grinding of minerals
CONCRETE MANUFACTURE Generally wet process	Mixing of materials Proportioning of bulk materials Drying Water assisted dust suppression Plastic shaping
POST-PRODUCTION	Final treatment (dry) General storage (indoor and outdoor) Handling and transportation systems
Cleaning	Mould cleaning Handling and transportation systems
Not every process step is necessary for every precast concrete product	

Part 2: Task manual

The aim of this part of the Good Practices Guide on dust prevention is to reduce risks to which workers may be exposed from respirable crystalline silica.

The first section is an introduction on respirable crystalline silica.

The second section contains a range of task guidance sheets which describe good practice techniques for various common and specific tasks. The general guidance sheets (section 2.1.) apply to all of the industries which are signatories of the Agreement on Workers' Health Protection through the Good Handling and Use of Crystalline Silica and Products containing it. The specific task sheets (section 2.2.) relate to tasks concerning only a limited number of industry sectors.

1. Introduction

What is respirable crystalline silica?

By definition, respirable crystalline silica is the fraction of airborne crystalline silica dust that can penetrate the alveoli (gas exchange region) of the lung.

In the case of crystalline silica dust, it is the respirable fraction of the dust that is of concern for its health effects. These particles are so small that they cannot be seen with the naked eye. Once airborne, respirable dust takes a very long time to settle. A single release of dust into the workplace air can lead to significant exposure. In fact, in situations where the air is constantly stirred up and where no fresh air is being introduced, respirable dust may remain airborne in the workplace for days.

How does respirable crystalline silica get into the body?

Respirable crystalline silica enters the body when dust containing a proportion of crystalline silica is inhaled. When the particle size range of the dust is sufficiently small (such that the particles fall within the respirable fraction), the dust will travel deep into the lungs. It is at this point that respirable crystalline silica can cause health effects.

What are the known health effects associated to respirable crystalline silica exposure?

The principal health effect associated to the inhalation of respirable crystalline silica is silicosis.

Silicosis is one of the most common types of pneumoconiosis. Silicosis is a nodular progressive fibrosis caused by the deposition in the lungs of fine respirable particles of crystalline silica. When one experiences prolonged overexposure, the body's natural defence mechanisms may find it difficult to clear respirable crystalline silica from the lungs. An accumulation of dust can, in the long term, lead to irreversible health effects. These health effects involve scarring of the innermost parts of the lungs that can lead to breathing difficulties and, in some cases, death. Larger (non-respirable) particles are more

likely to settle in the main airways of the respiratory system and may be cleared by mucus action.

Silicosis is one of the world's oldest known occupational diseases and is caused by the inhalation of respirable crystalline silica (Stacey P.R 2005).

Workers are rarely exposed to pure crystalline silica. The dust they breathe in the workplace is usually composed of a mixture of crystalline silica and other materials.

The response of an individual is likely to depend on:

- the nature and silica content of the dust
- the dust fraction
- the extent and nature of personal exposure (duration, frequency and intensity, which may be influenced by the working methods)
- personal physiological characteristics
- smoking habits

Where is respirable crystalline silica found?

Occupational exposure to respirable crystalline silica can occur in any workplace situation where airborne dust is generated, which contains a proportion of respirable crystalline silica.

Occupational exposure to respirable crystalline silica occurs in many industries including quarrying, mining, mineral processing (e.g. drying, grinding, bagging and handling); slate working; stone crushing and dressing; foundry work; brick and tile making; some refractory processes; construction work, including work with stone, concrete, brick and some insulation boards; tunnelling, building restoration (painting) and in the pottery and ceramic industries.

How to use the Task Sheets

At each site, before commencing any work activity that may result in occupational exposure to respirable crystalline silica, employers must carry out a risk assessment to identify the source, nature and extent of that exposure.

When the risk assessment identifies that workers may be exposed to respirable crystalline silica, then control measures should be put in place to control exposures.

The following task sheets identify appropriate control measures that will assist employers in reducing exposure levels for many common work activities. When deciding which task sheet(s) to apply, priority should be given to the most significant sources of exposure to respirable crystalline silica in the workplace.

Depending on the specific circumstances of each case, it may not be necessary to apply all of the control measures identified in the task sheets in order to minimise exposure to respirable crystalline silica i.e. to apply appropriate protection and prevention measures as required by Section II of Directive 98/24.

2. Task Guidance Sheets

	Aggregates	Cement	Ceramic	Precast Concrete	Foundry	Glass	Industrial Minerals	Mineral Wool	Mining	Mortar	Natural Stones
2.2. Specific task sheets											
2.2.1.	(a) Bag emptying – small bags	x	x		x	x	x		x	x	
	(b) Bag emptying – bulk bags	x	x		x	x	x		x	x	
2.2.2.	Batch charging into the process - Glass					x					
2.2.3.	(a) Bulk road tanker loading	x			x		x		x	x	
	(b) Bulk loading	x	x		x		x		x	x	
2.2.4.	(a) Bulk road tanker unloading (blowing off)	x		x	x	x	x		x	x	
	(b) Bulk unloading	x	x		x	x	x		x	x	
2.2.5.	Core making and moulding in foundries				x						
2.2.6.	Crushing of minerals	x	x		x		x		x		
2.2.7.	Cutting and polishing refractory materials and glass			x		x					
2.2.8.	Drying minerals	x	x				x			x	
2.2.9.	Dry pressing			x							
2.2.10.	Fettling larger castings in foundries					x					
2.2.11.	Fettling smaller castings in foundries					x					
2.2.12.	Final treatment (dry)			x	x						
2.2.13.	Firing (biscuit, glaze, final, decoration)			x							
2.2.14.	Glass furnace batch charging - container glass						x				
2.2.15.	Glass sandblasting						x				
2.2.16.	Grinding of minerals	x	x		x		x				
2.2.17.	Grinding of glass						x				
2.2.18.	Isostatic pressing (dry)			x							
2.2.19.	Jumbo bagging	x	x				x			x	
2.2.20.	Knock-out and shake-out in foundries					x					
2.2.21.	Lining and Break-out					x					
2.2.22.	Mixing of materials		x	x	x	x	x			x	
2.2.23.	Periodic and continuous drying			x	x	x					
2.2.24.	Plastic shaping			x	x						
2.2.25.	Preparation			x							
2.2.26.	Preparing sand in foundries					x					

2. Task Guidance Sheets

	Aggregates	Cement	Ceramic	Precast Concrete	Foundry	Glass	Industrial Minerals	Mineral Wool	Mining	Mortar	Natural Stones
2.2.27. (a) Proportioning (small quantities)			x								
(b) Proportioning of bulk materials			x	x							
2.2.28. Quarry mobile plant – excavation and haulage	x	x					x		x	x	
2.2.29. Screening	x	x					x		x		
2.2.30. Shot-blasting in foundries					x						
2.2.31. (a) Small bag filling – coarse products							x			x	
(b) Small bag filling - flours		x					x			x	
2.2.32. Spray drying			x	x							
2.2.33. Spray glazing			x								
2.2.34. Transport systems for fine dry silica products			x				x				
2.2.35. Use of a drilling rig	x	x					x		x		
2.2.36. Water assisted dust suppression		x	x	x							

2.1.1

This guidance sheet is aimed at employers to help them comply with the requirements of workplace health and safety legislation, by controlling exposure to respirable crystalline silica.

Specifically, this sheet provides advice on dust control during cleaning operations in the workplace. Following the key points of this task sheet will help reduce exposure. Depending on the specific circumstances of each case, it may not be necessary to apply all of the control measures identified in this sheet in order to minimize exposure to respirable crystalline silica. i.e. to apply appropriate protection and prevention measures.

This document should also be made available to persons who may be exposed to respirable crystalline silica in the workplace, in order that they may make the best use of the control measures which are implemented.

This sheet forms part of the Good Practices Guide on silica dust prevention, which is aimed specifically at the control of personal exposure to respirable crystalline silica dust in the workplace.



Cleaning

This activity relates to cleaning of surfaces in the workplace of substances, which may contain a proportion of crystalline silica dust. Cleaning should be carried out in a routine basis, but may also be required in response to a spillage of a substance containing crystalline silica.

Access

- ✓ Restrict access to the work area to authorised personnel only.

Design and equipment

Wet cleaning:

- ✓ Dust control can be achieved using wet cleaning methods, which prevent fine dust from becoming airborne by trapping it in water.
- ✓ Wet cleaning methods may involve mopping, wet brushing or the use of water sprays or hoses.
- ✓ Where water sprays are used, ensure that water supplies are adequate and that they are maintained. Take extra precautions during cold weather to protect against freezing.
- ✓ When wetting bulk spillages of fine, dry dusty material it is best to use a fine mist. The use of a jet of water will cause dust to become airborne.
- ✓ Where wet cleaning methods are used, electrical installations must be designed with protection against water ingress.
- ✓ The provision of appropriate drainage systems is essential when using water sprays and hoses.

Dry cleaning:

- ✓ Dust control can be achieved using dry cleaning methods, which involve vacuuming of the dry dust.
- ✓ Industrial vacuum cleaners may be portable units, equipped with high efficiency particulate filters (HEPA filter) or equivalent technique. Alternatively a building may be equipped with an integrated vacuum cleaning system, with strategically located connections leading to a central dust collector.
- ✓ Vacuum systems may need to be of an approved type.
- ✓ If vacuum cleaning systems will need to deal with large or bulk spillages of powdered material, they should be especially designed to avoid overloading or blocking.
- ✓ When wet cleaning or vacuum cleaning is not possible and only dry cleaning with brushes can be done, ensure that the workers wear appropriate personal protective equipment and ensure that measures are taken to prevent crystalline silica dust from spreading outside the working area.
- ✗ Vacuum cleaning systems are not generally suitable for cleaning up spillages of damp materials.

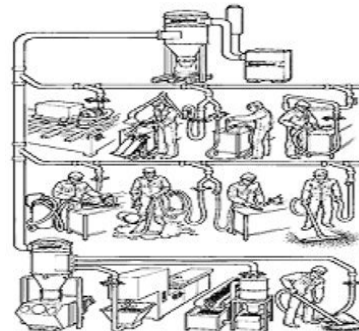

Maintenance

- ✓ Ensure equipment used in the task is maintained as advised by the supplier/installer in efficient working order and in good repair.
- ✓ Replace consumables (filters etc) in accordance with the manufacturer's recommendations.

Examination and testing

- ✓ Visually check the cleaning equipment for signs of damage at least once per week or, if it is in constant use, check it more frequently. If used infrequently, then check it before each use.
- ✓ Have cleaning equipment tested against its performance standard at least once each year.
- ✓ Keep records of inspections for a suitable period of time which complies with national laws (minimum five years).

Cleaning and housekeeping

- ✓ In order to prevent dust accumulating, clean your workplace on a regular basis.
- ✓ Deal with spills immediately. When dealing with bulk spillages of fine, dry, dusty materials, ensure that cleaning work is undertaken following a written safe working procedure and using the information in this task sheet.
- ✗ **Do not clean up with a dry brush or using compressed air.**
- ✓ Use vacuum or wet cleaning methods.

Personal Protective Equipment

- ✓ Refer to task sheet 2.1.15 dedicated to Personal Protective Equipment.
- ✓ -Risk assessment must be carried out to determine whether existing controls are adequate. If necessary, respiratory protective equipment (with the appropriate protection factor) should be provided and worn.
- ✓ Provide storage facilities to keep personal protective equipment clean when not in use.
- ✓ Replace respiratory protective equipment at intervals recommended by its suppliers.
- ✓ When cleaning dry dust, the employer must provide appropriate clothing which avoids dust being absorbed. Your workwear supplier will be able to advise you of appropriate clothing.

Training

- ✓ Give your employees information on the health effects associated with respirable crystalline silica dust
- ✓ Provide employees with training on: dust exposure prevention; checking controls are working and using them; when and how to use any respiratory protective equipment provided and what to do if something goes wrong. Refer to task sheet 2.1.19 and part 1 of the Good Practice Guide.

Supervision

- ✓ Have a system to check that control measures are in place and that they are being followed. Refer to task sheet 2.1.17.
- ✓ Employers should make sure that employees have all the means to perform the checklist given opposite

Employee checklist for making the best use of the controls

- ☐ **For wet cleaning methods, make sure the water supply is working properly before starting the cleaning work.**
- ☐ **For dry cleaning methods, make sure the vacuum cleaning system is working efficiently.**
- ☐ **Check the condition of the filters used in vacuum cleaners weekly. Replace them if necessary.**
- ☐ **Follow appropriate procedures when emptying vacuum cleaners of dust.**
- ☐ **When cleaning up bulk spillages of fine, dry dusty materials, ensure that you work in accordance with your Company's written safe working procedure.**
- ☐ **Look for signs of damage, wear or poor operation of any equipment used. If you find any problems, tell your supervisor. If you think there is a problem with your dust control equipment, ensure additional control measures are taken to reduce exposure to respirable crystalline silica dust while the problem persists..**
- ☐ **Use, maintain and store any personal protective equipment provided in accordance with instructions.**

This guidance sheet is aimed at employers to help them comply with the requirements of workplace health and safety legislation, by controlling exposure to respirable crystalline silica.

Specifically, this sheet provides advice on the design of buildings in which activities are conducted that may cause the generation of respirable crystalline silica. Following the key points of this task sheet will help reduce exposure. Depending on the specific circumstances of each case, it may not be necessary to apply all of the control measures identified in this sheet in order to minimize exposure to respirable crystalline silica. i.e. to apply appropriate protection and prevention measures.

This document should also be made available to persons who may be exposed to respirable crystalline silica in the workplace, in order that they may make the best use of the control measures which are implemented.

This sheet forms part of the Good Practices Guide on silica dust prevention, which is aimed specifically at the control of personal exposure to respirable crystalline silica dust in the workplace.

Design of buildings

This sheet provides guidance on the design of buildings in which activities are conducted that may cause the generation of respirable crystalline silica dust.

Access

- ✓ Restrict access to the work area to authorised personnel only.

Design and equipment

- ✓ Ensure the building is adequately ventilated, using forced ventilation if necessary. Ensure the ventilation system does not cause settled dust to be stirred up and that contaminated air does not spread to clean areas.
- ✓ Dust suppression sprays (sprinklers or fine mist) may be used to prevent the generation of airborne dust from indoor and outdoor traffic routes and from conveyors.
- ✓ Emissions from dust extraction systems in buildings into the environment must be in compliance with local environmental rules.
- ✓ Use walls and flooring surfaces that are easy to keep clean and that do not absorb/accumulate dust. Where necessary to prevent dust spreading between levels, use solid floors where possible and cover them with a wear resistant material which is coloured to highlight dust contamination.
- ✓ If wet cleaning methods or dust suppression sprays (sprinklers) are to be used, ensure that the flooring is designed to promote good drainage.
- ✓ Ensure that electrical systems etc have adequate protection against the hazards present in the working environment, including water and silica dust.
- ✓ Control panels can be protected using a membrane.
- ✓ Provide an adequate number of correctly positioned water connection points when using wet cleaning methods.
- ✓ Provide an adequate number of vacuum connection points when using a central vacuum cleaning system.
- ✓ The provision of control rooms helps to keep operators isolated from sources of respirable crystalline silica dust.
- ✓ Control rooms should have their own, clean air supply and they should be sealed and physically separated from dusty areas. To avoid dust contaminated air entering these rooms, it may be necessary to ventilate them using positive pressure systems. Refer to task sheet 2.1.3. on Design of control rooms.
- ✓ Equipment with low maintenance requirements should be selected where possible. eg the use of machinery equipped with automatic greasing systems will reduce the amount of time spent by maintenance personnel in dusty areas.
- ✓ The installation of closed circuit television (CCTV) systems, viewed from a clean control room, may help to reduce the need for plant operators to spend time in dusty areas.

Maintenance

- ✓ Maintain the building and all equipment provided for dust control as advised by the supplier/installer.

Examination and testing

- ✓ Check the condition of the building and the performance of all dust control equipment at least once per week for signs of damage or reduced efficiency. If it is in constant use, check it more frequently. If used infrequently, then check it before each use.
- ✓ Have dust control equipment tested against its performance standard, at least once each year.
- ✓ Keep records of inspections for a suitable period of time which complies with national laws (minimum five years).

Cleaning and housekeeping

- ✓ Clean floors and other surfaces regularly.
- ✗ **Do not clean up with a dry brush or using compressed air.**
- ✓ Use vacuum or wet cleaning methods.

Personal Protective Equipment

- ✓ Refer to task sheet 2.1.15 dedicated to Personal Protective Equipment.
- ✓ Indicate areas where personal protective equipment (e.g. dust masks) must be worn using appropriate signs.
- ✓ Provide storage facilities to keep personal protective equipment clean when not in use.
- ✓ Provide adequate supplies of personal protective equipment. Ensure that it is readily obtainable. If necessary, provide boxes of personal protective equipment (e.g. dust masks) at the entrances to buildings. Identify the locations of these supplies using appropriate signs

Training

- ✓ Give your employees information on the health effects associated with respirable crystalline silica dust
- ✓ Provide employees with training on: dust exposure prevention; checking controls are working and using them; when and how to use any respiratory protective equipment provided and what to do if something goes wrong. Refer to task sheet 2.1.19 and part 1 of the Good Practice Guide.

Supervision

- ✓ Have a system to check that control measures are in place and that they are being followed. Refer to task sheet 2.1.17.
- ✓ Employers should make sure that employees have all the means to perform the checklist given opposite.

Employee checklist for making the best use of the controls

- ☐ **Look for signs of damage or wear of building parts. If you find any problems, tell your supervisor.**
- ☐ **Look for signs of damage, wear or poor operation of any equipment used. If you find any problems, tell your supervisor. Do not carry on working if you think there is a problem.**
- ☐ **If you think there is a problem with your dust control equipment, ensure additional control measures are taken to reduce exposure to respirable crystalline silica dust while the problem persists.**

2.1.3

Design of control rooms

This sheet provides guidance on the design of control rooms. The provision of such facilities helps to keep operators isolated from sources of respirable crystalline silica dust in the workplace.

This guidance sheet is aimed at employers to help them comply with the requirements of workplace health and safety legislation, by controlling exposure to respirable crystalline silica.

Specifically, this sheet provides advice on the design of control rooms, which may be provided to isolate operators from sources of respirable crystalline silica. Following the key points of this task sheet will help reduce exposure. Depending on the specific circumstances of each case, it may not be necessary to apply all of the control measures identified in this sheet in order to minimize exposure to respirable crystalline silica. i.e. to apply appropriate protection and prevention measures.

This document should also be made available to persons who may be exposed to respirable crystalline silica in the workplace, in order that they may make the best use of the control measures which are implemented.

This sheet forms part of the Good Practices Guide on silica dust prevention, which is aimed specifically at the control of personal exposure to respirable crystalline silica dust in the workplace.

Access

- ✓ Restrict access to the work area to authorised personnel only.

Design and equipment

- ✓ Control rooms should have their own, clean air supply and they should be sealed and physically separated from dusty areas.
- ✓ To avoid dust contaminated air entering these rooms, it may be necessary to ventilate them using positive pressure systems.
- ✓ Doors and windows should be kept closed where necessary to prevent dust entering. Remember that the air outside the control room may be contaminated!
- ✓ Use flooring surfaces and furniture that are easy to keep clean and that do not absorb dust. Use solid floors (rather than grid/mesh) and seal them with a wear resistant material which is coloured to highlight dust contamination.
- ✓ Ensure that electrical control systems etc have adequate protection against the hazards present in the working environment, including silica dust.
- ✓ Control panels can be protected using a membrane.
- ✓ Provide an adequate number of vacuum connection points when using a central vacuum cleaning system.
- ✓ Provide sufficient windows to allow the process to be monitored from within the control room.
- ✓ The installation of closed circuit television (CCTV) systems and other telemetry, viewed from a clean control room, may help to reduce the need for plant operators to spend time in dusty areas.
- ✓ Provide facilities, including notice boards, for the communication of health and safety information, safe working procedures etc.



Maintenance

- ✓ Maintain the control room and all equipment provided for dust control as advised by the supplier/installer.

Examination and testing

- ✓ Check the condition and the performance of all dust control equipment at least once per week for signs of damage or reduced efficiency. If it is in constant use, check it more frequently. If used infrequently, then check it before each use.
- ✓ Have dust control equipment tested against its performance standard in compliance with local legal requirements, at a frequency which meets with manufacturers' recommendations and which complies with the outcome of a risk assessment.
- ✓ Keep records of inspections for a suitable period of time which complies with national laws (minimum five years).

Cleaning and housekeeping

- ✓ Clean floors and other surfaces regularly.
- ✗ **Do not clean up with a dry brush or using compressed air.**
- ✓ Use vacuum or wet cleaning methods.

Personal Protective Equipment

- ✓ Refer to task sheet 2.1.15 dedicated to Personal Protective Equipment.
- ✓ Indicate areas where personal protective equipment (e.g. dust masks) must be worn using appropriate signs.
- ✓ Provide storage facilities to keep personal protective equipment clean when not in use.
- ✓ Provide adequate supplies of personal protective equipment. Ensure that it is readily obtainable. Provide boxes of personal protective equipment (e.g. dust masks) in control rooms so that they can be used in the event of a problem with the production process. Identify the locations of these supplies using appropriate signs

Training

- ✓ Give your employees information on the health effects associated with respirable crystalline silica dust
- ✓ Provide employees with training on: dust exposure prevention; checking controls are working and using them; when and how to use any respiratory protective equipment provided and what to do if something goes wrong. Refer to task sheet 2.1.19 and part 1 of the Good Practice Guide.

Supervision

- ✓ Have a system to check that control measures are in place and that they are being followed. refer to task sheet 2.2.17.
- ✓ Employers should make sure that employees have all the means to perform the checklist given opposite.

Employee checklist for making the best use of the controls

- ☐ **Keep control rooms clean in order to prevent dust being stirred up.**
- ☐ **For dry dusts, use vacuum or wet cleaning methods.**
- ☐ **Keep doors and windows of control rooms closed to prevent dust entering.**
- ☐ **Remember that airborne respirable crystalline silica dust cannot be seen with the naked eye. However, an accumulation of fine dust on surfaces inside the control room may indicate that dust control measures are not working correctly.**
- ☐ **Look for signs of damage, wear or poor operation of any equipment used. If you find any problems, tell your supervisor. Do not carry on working if you think there is a problem.**
- ☐ **If you think there is a problem with your dust control equipment, ensure additional control measures are taken to reduce exposure to respirable crystalline silica dust while the problem persists.**

2.1.4.

Design of ducting

This activity covers design of the ductwork, which makes up part of a dust extraction system.

This guidance sheet is to be read in conjunction with the sheets entitled "local exhaust ventilation" and "design of dust extraction units".

This guidance sheet is aimed at employers to help them comply with the requirements of workplace health and safety legislation, by controlling exposure to respirable crystalline silica.

Specifically, this sheet provides advice on the design of ducting, for connection to a dust extraction unit in the workplace. It describes the key points you need to follow to help design an efficient system of ductwork, which is easy to maintain. Depending on the specific circumstances of each case, it may not be necessary to apply all of the control measures identified in this sheet in order to minimize exposure to respirable crystalline silica. i.e. to apply appropriate protection and prevention measures.

This document should also be made available to persons who may be exposed to respirable crystalline silica in the workplace, in order that they may make the best use of the control measures which are implemented.

This sheet forms part of the Good Practices Guide on silica dust prevention, which is aimed specifically at the control of personal exposure to respirable crystalline silica dust in the workplace.

Access

- ✓ Restrict access to the work area to authorised personnel only.

Design and equipment

- ✓ Use a reputable supplier of ducting. Contact only qualified engineers to quote for the work.
- ✓ Keep ducts short and simple.
- ✓ Avoid long sections of flexible duct, which add resistance that restricts the flow of air.
- ✓ Design ductwork to avoid dusts settling inside the duct.
- ✓ Settling of dust can be prevented by ensuring a transport velocity which is appropriate to the particle size and density. As an example, a velocity of 15m/s is typically required for coarse dusts, whereas a velocity of 5m/s may be sufficient for very fine dusts.
- ✓ Where ductwork is divided into several branches, optimal transport velocities can be achieved by varying the diameter of the ducting, such that it gets larger as it approaches the dust collector.
- ✓ Design ductwork to minimise internal wear, which may be associated with abrasive dusts.
- ✓ Choose an appropriate duct material, which is resistant to wear.
- ✓ To minimise resistance and wear, minimise the number of bends in ductwork. Where bends are necessary, make them gradual to reduce shock losses.
- ✓ Provide appropriate test points for use when checking the performance of a dust extraction system. Provide suitable sealing devices for these test points when not in use.

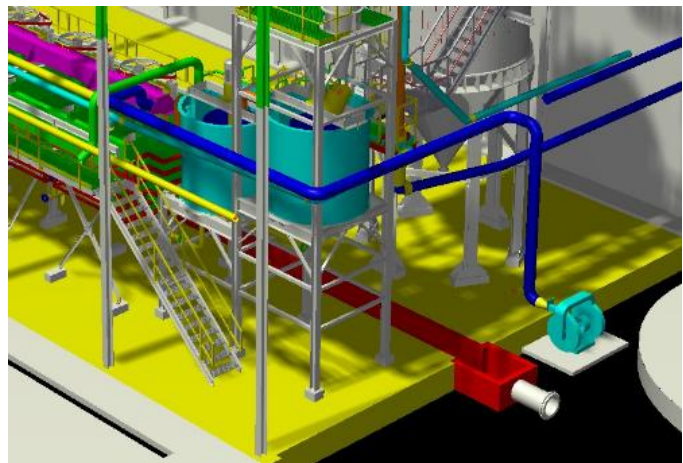

Maintenance

- ✓ Maintain the ductwork as advised by the supplier, in efficient working order and good repair.

Examination and testing

- ✓ Visually check ductwork at least once per week for signs of damage. If it is in constant use, check it more frequently. If used infrequently, then check it before each use.
- ✓ Check for any leaks in the ductwork and seal as necessary with duct sealing tape. Repair or replace any sections of ductwork that become damaged. Any dents will cause resistance to the flow of air, affecting the efficiency of the whole system.
- ✓ Have the whole system examined and tested against its performance standard at least once each year.
- ✓ Keep records of inspections for a suitable period of time which complies with national laws (minimum five years).

Cleaning and housekeeping

- ✓ If it becomes necessary to clean (or unblock) the internal surfaces of ductwork, this activity should be conducted by trained and competent individuals following a written safe working procedure.
- ✗ **Do not clean up with a dry brush or using compressed air.**
- ✓ Where possible, use vacuum cleaning methods to remove obstructions inside ducts. Use either vacuum or wet cleaning methods to clean up spillages of dust in the working environment.

Personal Protective Equipment

- ✓ Refer to task sheet 2.1.15 dedicated to Personal Protective Equipment.
- ✓ Risk assessment must be carried out to determine whether existing controls are adequate. If necessary, respiratory protective equipment (with the appropriate protection factor) should be provided and worn.
- ✓ Provide storage facilities to keep personal protective equipment clean when not in use.
- ✓ Replace respiratory protective equipment at intervals recommended by its suppliers.

Training

- ✓ Give your employees information on the health effects associated with respirable crystalline silica dust
- ✓ Provide employees with training on: dust exposure prevention; checking controls are working and using them; when and how to use any respiratory protective equipment provided and what to do if something goes wrong. Refer to task sheet 2.1.19 and part 1 of the Good Practice Guide.

Supervision

- ✓ Have a system to check that control measures are in place and that they are being followed. Refer to task sheet 2.1.17.
- ✓ Employers should make sure that employees have all the means to perform the checklist given opposite.

Employee checklist for making the best use of the controls

- ☐ **Look for signs of damage, wear or poor operation of any equipment used. If you find any problems, tell your supervisor.**
- ☐ **If you think there is a problem with your dust control equipment, ensure additional control measures are taken to reduce exposure to respirable crystalline silica dust while the problem persists.**
- ☐ **Clear up spills straight away. For dry dusts, use vacuum or wet cleaning methods.**
- ☐ **Use, maintain and store any respiratory protective equipment provided in accordance with instructions.**

2.1.5

Design of dust extraction units

This activity relates to the design of dust extraction units (i.e. fan, filter and dust collector) which make up part of a dust extraction system.

This guidance sheet is to be read in conjunction with the sheets entitled "Design of ducting" and "Local exhaust ventilation".

This guidance sheet is aimed at employers to help them comply with the requirements of workplace health and safety legislation, by controlling exposure to respirable crystalline silica.

Specifically, this sheet provides advice on the design of dust extraction units, which make up part of a dust extraction system. Following the key points of this task sheet will help reduce exposure.

Depending on the specific circumstances of each case, it may not be necessary to apply all of the control measures identified in this sheet in order to minimize exposure to respirable crystalline silica.

i.e. to apply appropriate protection and prevention measures.

This document should also be made available to persons who may be exposed to respirable crystalline silica in the workplace, in order that they may make the best use of the control measures which are implemented.

This sheet forms part of the Good Practices Guide on silica dust prevention, which is aimed specifically at the control of personal exposure to respirable crystalline silica dust in the workplace.

Dust extraction systems are used to capture dust at transfer points, chutes and many other dusty points in industrial processes.

All installations must conform to European standards.

Access

- ✓ Restrict access to the work area to authorised personnel only.

Design and equipment

- ✓ In order to prevent emission of dust, equipment handling materials containing crystalline silica dust should be designed so that ductwork is always under negative pressure, properly sealed (in case the negative pressure fails) and with no more flanges and inspections holes than necessary.
- ✓ Examples of dust extraction units include drop-out boxes, cyclones, wet scrubbers, bag filters and electrostatic precipitators. Some units use a combination of techniques.
- ✓ When selecting filter units, consider
 - ✓ the need for a pre-separator (pre-cyclone);
 - ✓ the dust loading, moisture content and particle size distribution;
 - ✓ the total air flow and maximum temperature at the filter;
 - ✓ the presence of any chemical contaminants in the air;
 - ✓ chimney stack particulate emission limits;
 - ✓ environmental noise limits;
 - ✓ maintenance requirements (frequency, work required);
 - ✓ their location, which should be outside the main working area, away from draughts and the prevailing wind;
 - ✓ the need for inclination of more than 60° at the base of the discharge hopper to help prevent blockages.
- ✓ If it is necessary to clean non-process air, a bag filter should be used (the use of a cyclone is not appropriate)
- ✓ Design the chimney with appropriate access and sockets for emission monitoring.



Stand-alone filter

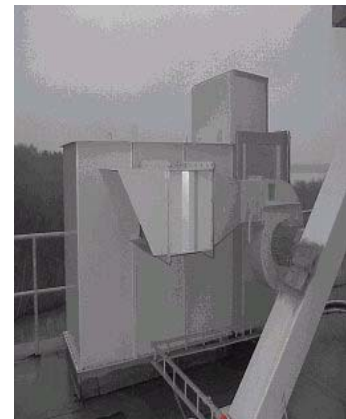

Direct bin filter

Maintenance

- ✓ Ensure dust extraction equipment is maintained as advised by the supplier/installer in efficient working order and in good repair. Replace filter cloth and other consumables in accordance with the manufacturer's recommendations.
- ✓ **Take extra measures regarding protection of employees during maintenance activities of dust extraction systems.**

Examination and testing

- ✓ The condition of a filter can be monitored by checking the pressure drop across it using a pressure gauge.
- ✓ Stack emissions testing and/or continuous monitoring from dust extractors (with audible and visual alarms) is required to check the performance of the system.
- ✓ Have the whole system examined and tested against its performance standard upon installation and at least once each year.
- ✓ Keep records of inspections for a suitable period of time which complies with national laws (minimum five years).

Cleaning and housekeeping

- ✓ Deal with spills immediately.
- ✗ **Do not clean up with a dry brush or using compressed air.**
- ✓ Use vacuum or wet cleaning methods.

Personal Protective Equipment

- ✓ Refer to task sheet 2.1.15. dedicated to Personal Protective Equipment.
- ✓ Risk assessment must be carried out to determine whether existing dust controls are adequate. If necessary, respiratory protective equipment (with the appropriate protection factor) should be provided and worn (e.g. during maintenance activities of dust extraction equipment).
- ✓ Provide storage facilities to keep personal protective equipment clean when not in use.
- ✓ Replace respiratory protective equipment at intervals recommended by its suppliers.

Training

- ✓ Give your employees information on the health effects associated with respirable crystalline silica dust
- ✓ Provide employees with training on: dust exposure prevention; checking controls are working and using them; when and how to use any respiratory protective equipment provided and what to do if something goes wrong. Refer to task sheet 2.1.19 and part 1 of the Good Practice Guide.

Supervision

- ✓ Have a system to check that control measures are in place and that they are being followed. Refer to task sheet 2.1.17.
- ✓ Employers should make sure that employees have all the means to perform the checklist given opposite.

Employee checklist for making the best use of the controls

- ☐ **Check the pressure drop across the filter daily to ensure that it remains within the acceptable range.**
- ☐ **Check the condition of the filters cloths regularly.**
- ☐ **Look for signs of damage, wear of poor operation of any equipment used. If you find any problems, tell your supervisor.**
- ☐ **If you think there is a problem with your dust control equipment, ensure additional control measures are taken to reduce exposure to respirable crystalline silica dust while the problem persists.**
- ☐ **Follow appropriate procedures when working with dust extraction systems.**

Dust monitoring

This sheet provides advice on how to implement dust monitoring in order to assess personal exposure levels to respirable crystalline silica dust.

This guidance sheet is aimed at employers to help them comply with the requirements of workplace health and safety legislation, by controlling exposure to respirable crystalline silica.

Specifically, this sheet provides advice on good practice advice on personal dust exposure monitoring. It describes the key points you need to consider when establishing a dust monitoring programme. Depending on the specific circumstances of each case, it may not be necessary to apply all of the control measures identified in this sheet in order to minimize exposure to respirable crystalline silica. i.e. to apply appropriate protection and prevention measures.

This document should also be made available to persons who may be exposed to respirable crystalline silica in the workplace, in order that they may make the best use of the control measures which are implemented.

This sheet forms part of the Good Practices Guide on silica dust prevention, which is aimed specifically at the control of personal exposure to respirable crystalline silica dust in the workplace.

Access

- ✓ Restrict access to the work area to authorised personnel only.

Design and equipment

Both personal and static measurements can be used jointly as there are complementary. It is up to the experts designated by the employers and the employees' representatives to opt for the more adequate solutions, while respecting the national and European provisions.

The following general requirements (taken from the European Standards EN 689 and EN 1232) should be followed:

- ✓ Define a monitoring strategy: choose appropriate sampling equipment, define the job functions to be monitored, identify the appropriate personnel who will carry out the sampling and analysis, plan the dates of the measurement campaign.
- ✓ Use sampling equipment that conforms to European Standard EN 481. Use a recognised analytical technique to measure respirable crystalline silica: X-ray diffraction or infrared spectroscopy.
- ✓ The persons carrying out the sampling and analysis must be appropriately trained and experienced.
- ✓ In the case of crystalline silica, it is the respirable fraction that is of concern for its health effects. Therefore the respirable dust fraction should be collected.
- ✓ In the case of personal sampling, the sampling equipment must be worn by the worker and the sampling head must be positioned in the worker's breathing zone (less than 30cm from the mouth and nose area).
- ✓ Sampling duration should be as close as possible to a full working shift in order to ensure that samples are representative.
- ✓ Collect sufficient number of samples per campaign for each job function in order to get a follow up of each worker. Take into account variation of work activities on different days eg cleaning work is often done on Fridays.
- ✓ Inform the workers that dust monitoring will be undertaken and the reasons for it. This will help to ensure full co-operation. Inform them of the results of the dust monitoring.
- ✓ Record information during the sampling, including: date, job function, worker's name, shift length, sample flow rate and duration, work activities and working practices, weather conditions, personal protective equipment worn, comments on dust control measures, production process, tonnage rate etc
- ✓ Check the correct operation of the sampling equipment (including the flow rate) at regular intervals during the shift and keep records of these checks.

Keep full documentation on the dust monitoring campaigns and adopt a quality system as described above.



Maintenance

- ✓ Ensure dust sampling equipment is maintained as advised by the supplier/installer in efficient working order and in good repair.
- ✓ Keep the sampling equipment clean to prevent contamination of future samples.
- ✓ It may be necessary to disassemble sampling heads in order to clean them properly.
- ✓ If cleaning sampling heads using wet cleaning methods, ensure that they are allowed to dry out fully before re-use.
- ✓ Replace consumables (batteries etc) in accordance with the manufacturer's recommendations

Examination and testing

- ✓ Visually check the sampling equipment before and after each use for signs of damage.
- ✓ Have the sampling equipment serviced regularly, in accordance with manufacturers' recommendations.
- ✓ Keep records of inspections for a suitable period of time which complies with national laws (minimum five years).

Personal Protective Equipment

- ✓ Refer to task sheet 2.1.15. dedicated to Personal Protective Equipment.
- ✓ Risk assessment must be carried out to determine whether existing controls are adequate. If necessary, respiratory protective equipment (with the appropriate protection factor) should be provided and worn.
- ✓ Personnel conducting sampling work should set a good example by wearing respiratory protective equipment in the required areas.
- ✓ Provide storage facilities to keep personal protective equipment clean when not in use.
- ✓ Replace respiratory protective equipment at intervals recommended by its suppliers.

Training

- ✓ Give your employees information on the health effects associated with respirable crystalline silica dust
- ✓ Provide employees with training on: dust exposure prevention; checking controls are working and using them; when and how to use any respiratory protective equipment provided and what to do if something goes wrong. Refer to task sheet 2.1.19 and part 1 of the Good Practice Guide.

Supervision

- ✓ Have a system to check that control measures are in place and that they are being followed. Refer to task sheet 2.1.17.
- ✓ Employers should make sure that employees have all the means to perform the checklist given opposite.

Employee checklist for making the best use of the controls

- ☐ **Look for signs of damage, wear or poor operation of any equipment used. If you find any problems, do not use the sampling equipment.**
- ☐ **Ensure that sampling pumps are fully re-charged prior to commencing each shift's sampling work.**
- ☐ **Regularly check the correct operation of the sampling equipment during the shift. In particular. Where possible, check that the sampling flow rate is still correct and adjust if necessary.**
- ☐ **Keep detailed records of operator work activities etc observed during sampling.**
- ☐ **Do not try to collect too many samples in one shift. Quality is better than quantity!**
- ☐ **Use, maintain and store sampling equipment in accordance with instructions.**

General indoor storage

This activity covers design of general indoor storage in plants where crystalline silica containing products are present.

This guidance sheet is aimed at employers to help them comply with the requirements of workplace health and safety legislation, by controlling exposure to respirable crystalline silica.

Specifically, this sheet provides advice on dust control when storing small, medium and large quantities of crystalline silica containing products. Following the key points of this task sheet will help reduce exposure.

Depending on the specific circumstances of each case, it may not be necessary to apply all of the control measures identified in this sheet in order to minimize exposure to respirable crystalline silica. i.e. to apply appropriate protection and prevention measures.

This document should also be made available to persons who may be exposed to respirable crystalline silica in the workplace, in order that they may make the best use of the control measures which are implemented.

This sheet forms part of the Good Practices Guide on silica dust prevention, which is aimed specifically at the control of personal exposure to respirable crystalline silica dust in the workplace.

Access

- ✓ Restrict access to the work area to authorised personnel only.

Design and equipment

General design aspects:

- ✓ Define a specific area for storage, which is clearly identified using appropriate signs.
- ✓ The area should be spacious, organised, well lit and well ventilated.
- ✓ Demarcate storage areas by painting lines on the floor and/or using appropriate signs.
- ✓ The installation of partitions in buildings will help to reduce the spread of dust.
- ✓ Where possible, provide separate routes for pedestrians and vehicles.
- ✓ Ensure floors are impervious and easy to clean.
- ✓ Inflammable materials, such as empty packaging, must be kept in a separate store room.
- ✓ Design the layout of storage facilities to minimise risks from collisions between vehicles and stored materials.
- ✓ Limit the height to which pallets of stored materials are stacked so as to minimise the risk of them falling.
- ✓ Develop procedures for dealing with spillages and provide the necessary cleaning equipment (e.g. vacuum cleaner).
- ✓ Where reasonably practicable, cover stockpiles that are not in use with tarpaulins/plastic covers or, where appropriate, use spray membrane systems.

Silos:

- ✓ Provide dust filtration for air displaced from silos during filling.
- ✓ Put barriers around silos to prevent damage, e.g. by forklift trucks.
- ✓ Individually label feed lines.

Maintenance

- ✓ Ensure equipment used in the task is maintained as advised by the supplier/installer in efficient working order and in good repair.
- ✓ Adopt a "Permit to Work" system for maintenance work on storage tanks and silos.
- ✓ Follow any special procedures that are needed before opening or entering storage tanks and silos, e.g. purging and washing.

Examination and testing

- ✓ Visually check silos at least annually for signs of damage. Periodic specialist examination and testing should also be arranged in order to check the condition of silos.
- ✓ Keep records of inspections for a suitable period of time which complies with national laws (minimum five years).

Cleaning and housekeeping

- ✓ Maintain good housekeeping standards in storage areas and deal with spills immediately. Keep floors clean to prevent dust being stirred up by moving vehicles etc. Dispose of empty containers safely.
- ✓ Repackage any damaged or leaking packages, or dispose of them safely.
- ✗ **Do not clean up with a dry brush or using compressed air.**
- ✓ Use vacuum or wet cleaning methods.

Personal Protective Equipment

- ✓ Refer to task sheet 2.1.15 dedicated to Personal Protective Equipment.
- ✓ Risk assessment must be carried out to determine whether existing controls are adequate. If necessary, respiratory protective equipment (with the appropriate protection factor) should be provided and worn.
- ✓ Provide storage facilities to keep personal protective equipment clean when not in use.
- ✓ Replace respiratory protective equipment at intervals recommended by its suppliers.

Training

- ✓ Give your employees information on the health effects associated with respirable crystalline silica dust
- ✓ Provide employees with training on: dust exposure prevention; checking controls are working and using them; when and how to use any respiratory protective equipment provided and what to do if something goes wrong. Refer to task sheet 2.1.19 and part 1 of the Good Practice Guide.

Supervision

- ✓ Have a system to check that control measures are in place and that they are being followed. Refer to task sheet 2.1.17.
- ✓ Employers should make sure that employees have all the means to perform the checklist given opposite.

Employee checklist for making the best use of the controls

- ☐ **Make sure the room is well ventilated and any dust extraction system is switched on and is working.**
- ☐ **Look for signs of damage, wear or poor operation of any equipment used. If you find any problems, tell your supervisor.**
- ☐ **If you think there is a problem with your dust control equipment, ensure additional control measures are taken to reduce exposure to respirable crystalline silica dust while the problem persists.**
- ☐ **Use handling aids to move sacks and drums.**
- ☐ **Keep traffic and pedestrian routes clear and only store materials in demarcated areas.**
- ☐ **Clean up using vacuum or wet cleaning methods.**
- ☐ **Clear up spills straight away and dispose of spills safely.**
- ☐ **Use, maintain and store any respiratory protective equipment provided in accordance with instructions.**

General outdoor storage

This activity covers design of general outdoor storage in sites where crystalline silica containing products are present.

This guidance sheet is aimed at employers to help them comply with the requirements of workplace health and safety legislation, by controlling exposure to respirable crystalline silica.

Specifically, this sheet provides advice on dust control when externally storing variable quantities of crystalline silica containing products. Following the key points of this task sheet will help reduce exposure.

Depending on the specific circumstances of each case, it may not be necessary to apply all of the control measures identified in this sheet in order to minimize exposure to respirable crystalline silica.

i.e. to apply appropriate protection and prevention measures.

This document should also be made available to persons who may be exposed to respirable crystalline silica in the workplace, in order that they may make the best use of the control measures which are implemented.

This sheet forms part of the Good Practices Guide on silica dust prevention, which is aimed specifically at the control of personal exposure to respirable crystalline silica dust in the workplace.

Access

- ✓ Restrict access to the work area to authorised personnel only.

Design and equipment

General design aspects:

- ✓ Define a specific area for storage, which is clearly identified using appropriate signs.
- ✓ The area should be spacious, organised, and well lit.
- ✓ The careful siting and design of outdoor storage areas will help to reduce wind entrainment of dust.
- ✓ Where possible, provide separate routes for pedestrians and vehicles.
- ✓ Design the layout of storage facilities to minimise risks from vehicle overturns and collisions between vehicles
- ✓ Limit the height of external storage stockpiles, taking into consideration factors such as natural angle of repose; material type; moisture content.
- ✓ Whilst building outdoor stockpiles from under conveyor belt systems, where possible restrict the drop height, or otherwise reduce the free-fall of material by the use of cascade devices, where appropriate; and/or by the use of curtaining or retractable vertical chutes to shield the falling material from wind entrainment.
- ✓ Keep areas tidy in the vicinity of outdoor storage areas.

Maintenance

- ✓ Ensure equipment used in the task is maintained as advised by the supplier/installer in efficient working order and in good repair.

Examination and testing

- ✓ Visually check dust reduction features at least annually for signs of damage.
- ✓ Keep records of inspections for a suitable period of time which complies with national laws (minimum five years).

Cleaning and housekeeping

- ✓ Maintain good housekeeping standards in storage areas.

Personal Protective Equipment

- ✓ Refer to task sheet 2.1.15 dedicated to Personal Protective Equipment.
- ✓ Risk assessment must be carried out to determine whether existing controls are adequate. If necessary, respiratory protective equipment (with the appropriate protection factor) should be provided and worn.
- ✓ Provide storage facilities to keep personal protective equipment clean when not in use
- ✓ Replace respiratory protective equipment at intervals recommended by its suppliers.

Training

- ✓ Give your workers information on the health effects associated with respirable crystalline silica.
- ✓ Provide employees with training on: dust exposure prevention; checking controls are working and using them; when and how to use any respiratory protective equipment provided and what to do if something goes wrong. Refer to task sheet 2.1.19 and part 1 of the Good Practice Guide.

Supervision

- ✓ Have a system to check that control measures are in place and that they are being followed. Refer to task sheet 2.1.17.
- ✓ Employers should make sure that employees have all the means to perform the checklist given opposite

Employee checklist for making the best use of the controls

- ☐ Look for signs of damage, wear or poor operation of any equipment used. If you find any problems, tell your supervisor.
- ☐ If you think there is a problem with your dust control equipment, ensure additional control measures are taken to reduce exposure to respirable crystalline silica while the problem persists.
- ☐ Keep traffic and pedestrian routes clear of obstructions and, where possible, segregated.
- ☐ Use, maintain and store any respiratory protective equipment provided in accordance with instructions.

This activity covers design and use of general ventilation in plants where crystalline silica dust is present.

This guidance sheet is aimed at employers to help them comply with the requirements of workplace health and safety legislation, by controlling exposure to respirable crystalline silica.

Specifically, this sheet provides advice on dust control during the design and use of general ventilation in the workplace.

Following the key points of this task sheet will help reduce exposure. Depending on the specific circumstances of each case, it may not be necessary to apply all of the control measures identified in this sheet in order to minimize exposure to respirable crystalline silica. i.e. to apply appropriate protection and prevention measures.

This document should also be made available to persons who may be exposed to respirable crystalline silica in the workplace, in order that they may make the best use of the control measures which are implemented.

This sheet forms part of the Good Practices Guide on silica dust prevention, which is aimed specifically at the control of personal exposure to respirable crystalline silica dust in the workplace.

Access

- ✓ Restrict access to the work area to authorised personnel only.

Design and equipment

- ✓ Provide a good standard of general ventilation using natural ventilation from doors and windows, or forced ventilation where air is supplied or removed by a fan.
- ✓ Ventilation should ensure the removal of contaminated air and make it up with clean replacement air.
- ✓ Wall mounted fans can be used to extract or supply air. Fans may also be connected to ducting to help focus air supply and removal on specific areas.
- ✓ Ensure that supplied or make-up air comes from an uncontaminated area, or ensure that the air is filtered.
- ✓ Choose carefully the location at which make-up air enters the building. If people work in the vicinity, it may be necessary to warm the air, or take other measures to protect those individuals, in cold weather.
- ✓ Ensure that enough fresh air (20%) is supplied where employees are working to dilute and remove the airborne dust produced.
- ✓ Cleaned and filtered air can be reintroduced into the work area where employees are working provided systems are in place to check the condition and performance of the filtration system. Quantities of recirculated air should be in compliance with existing standards and regulations.
- ✓ Ensure, where possible, that air comes from a fresh source, flows past the worker and then past the work activity to the extraction point.
- ✓ Ensure that natural ventilation does not interfere with the performance of local exhaust ventilation systems by causing draughts.
- ✓ The design and specification of ventilation systems may need to be approved under national regulations.

Maintenance

- ✓ Ensure equipment used in the task is maintained as advised by the supplier/installer in efficient working order and in good repair.
- ✓ Replace consumables (filters etc) in accordance with the manufacturer's recommendations.

Examination and testing (if a ventilation system is provided)

- ✓ Obtain information on the design performance of the ventilation equipment from the supplier. Keep this information to compare with future test results.
- ✓ Visually check the ventilation equipment at least once per week for signs of damage. If it is in constant use, check it more frequently. If used infrequently, then check it before each use.
- ✓ Have the ventilation equipment examined and tested against its performance standard, at least once each year.
- ✓ Keep records of inspections for a suitable period of time which complies with national laws (minimum five years).

Cleaning and housekeeping

- ✓ Clean work area daily. Clean the workroom once a week.
- ✗ **Do not clean up with a dry brush or using compressed air.**
- ✓ Use vacuum or wet cleaning methods.

Personal Protective Equipment

- ✓ Refer to task sheet 2.1.15 dedicated to Personal Protective Equipment.
- ✓ Risk assessment must be carried out to determine whether existing controls are adequate. If necessary, respiratory protective equipment (with the appropriate protection factor) should be provided and worn.
- ✓ Provide storage facilities to keep personal protective equipment clean when not in use.
- ✓ Replace respiratory protective equipment at intervals recommended by its suppliers.

Training

- ✓ Give your employees information on the health effects associated with respirable crystalline silica dust
- ✓ Provide employees with training on: dust exposure prevention; checking controls are working and using them; when and how to use any respiratory protective equipment provided and what to do if something goes wrong. Refer to task sheet 2.1.19 and part 1 of the Good Practice Guide.

Supervision

- ✓ Have a system to check that control measures are in place and that they are being followed. Refer to task sheet 2.1.17.
- ✓ Employers should make sure that employees have all the means to perform the checklist given opposite.

Employee checklist for making the best use of the controls

- Make sure the room is well ventilated and any dust extraction system is switched on and is working.**
- Look for signs of damage, wear or poor operation of any equipment used. If you find any problems, tell your supervisor.**
- If you think there is a problem with your dust control equipment, ensure additional control measures are taken to reduce exposure to respirable crystalline silica dust while the problem persists.**
- Do not interfere with ventilation systems – they are provided to protect your working environment.**
- Clean up using vacuum or wet cleaning methods.**
- Use, maintain and store any respiratory protective equipment provided in accordance with instructions.**

2.1.10

Good hygiene

This activity covers good hygiene practices that should be followed in the workplace, for workers handling or having contact with substances that contain crystalline silica.

This guidance sheet is aimed at employers to help them comply with the requirements of workplace health and safety legislation, by controlling exposure to respirable crystalline silica.

Specifically, this sheet provides advice on good hygiene for workers who use products that contain crystalline silica. Following the key points of this task sheet will help reduce exposure.

Depending on the specific circumstances of each case, it may not be necessary to apply all of the control measures identified in this sheet in order to minimize exposure to respirable crystalline silica.

i.e. to apply appropriate protection and prevention measures.

This document should also be made available to persons who may be exposed to respirable crystalline silica in the workplace, in order that they may make the best use of the control measures which are implemented.

This sheet forms part of the Good Practices Guide on silica dust prevention, which is aimed specifically at the control of personal exposure to respirable crystalline silica dust in the workplace.

Access

- ✓ Restrict access to the work area to authorised personnel only.

Design and equipment

- ✓ Provide separate storage accommodation for workers' clean clothes, work clothes and personal protective equipment.
- ✓ Ensure the area is spacious, organised and well-ventilated.
- ✓ This area should have toilets, showers and wash basins as well as personal lockers.
- ✓ Consider providing separate "clean" and "dirty" lockers in situations where work clothes become very dirty.
- ✓ Consider providing a separate, well-ventilated, warm area where damp clothing can be hung up to dry.
- ✓ Note that the drying of damp, dirty clothes can lead to airborne dust generation. When overalls are dirty, exchange them for clean ones.
- ✓ Define a specific clean area where workers can prepare meals, eat and drink away from their workstation.
- ✓ Provide your workers with refrigerators for storing food and drink.
- ✓ Provide your workers with an adequate supply of clean working clothes, including spare sets. For those handling silica flour, overalls should be made of a finely woven fabric to prevent dust being absorbed. Workers should not take their dirty work clothes home; these should be cleaned by the employer as required.
- ✓ Workers should remove overalls before entering canteen facilities.
- ✗ Do not use compressed air to clean overalls.
- ✓ Air shower cabins can be used to clean overalls.
- ✗ Workers should not smoke at their workplace.



Maintenance

- ✓ Ensure equipment used in the task is maintained as advised by the supplier/installer in efficient working order and in good repair.
- ✓ Follow any special procedures that are needed to ensure good cleaning of the working equipment.

Examination and testing

- ✓ Visually check the cloakroom and the area designed for eating and drinking at least once per week for signs of damage. If used infrequently, then check it before each use.
- ✓ Visually check working clothes daily for signs of damage and dust.
- ✓ Keep records of inspections for a suitable period of time which complies with national laws (minimum five years).

Cleaning and housekeeping

- ✗ **Do not clean up with a dry brush or using compressed air.**
- ✓ Use vacuum or wet cleaning methods
- ✓ Keep eating / food preparation areas hygienically clean.
- ✓ Food and drink should not be stored or consumed at the workstation.
- ✓ Wash your hands before eating and drinking.
- ✓ Workers should shower daily at the end of their shift.

Personal Protective Equipment

- ✓ Refer to task sheet 2.1.15 dedicated to Personal Protective Equipment.
- ✓ Risk assessment must be carried out to determine whether existing controls are adequate. If necessary, respiratory protective equipment (with the appropriate protection factor) should be provided and worn.
- ✓ Provide storage facilities to keep personal protective equipment clean when not in use.
- ✓ Replace respiratory protective equipment at intervals recommended by its suppliers.

Training

- ✓ Give your employees information on the health effects associated with respirable crystalline silica dust
- ✓ Provide employees with training on: dust exposure prevention; checking controls are working and using them; when and how to use any respiratory protective equipment provided and what to do if something goes wrong. Refer to task sheet 2.1.19 and part 1 of the Good Practice Guide.

Supervision

- ✓ Have a system to check that control measures are in place and that they are being followed. Refer to task sheet 2.1.17.
- ✓ Employers should make sure that employees have all the means to perform the checklist given opposite.

Employee checklist for making the best use of the controls

- Look for signs of damage, wear or poor operation of any equipment used. If you find any problems, tell your supervisor. Do not carry on working if you think there is a problem.**
- Clean up using vacuum or wet cleaning methods.**
- Don't take your dirty overalls home.**
- Get your overalls washed by your employer.**
- Keep food preparation and eating areas hygienically clean.**
- Remove overalls before entering canteen facilities.**
- Don't store food or drink at your workstation. Use the refrigerated storage facilities provided by your employer.**
- Wash your hands thoroughly before eating.**
- Use, maintain and store any respiratory protective equipment provided in accordance with instructions.**
- Don't smoke in the workplace.**

Handling and transport systems

This relates to the different mechanical and pneumatic handling and transport systems for internal movement of crystalline silica containing products, particularly those which are dry.

This guidance sheet is aimed at employers to help them comply with the requirements of workplace health and safety legislation, by controlling exposure to respirable crystalline silica.

Specifically, this sheet provides advice on transport systems. Following the key points of this task sheet will help reduce exposure. Depending on the specific circumstances of each case, it may not be necessary to apply all of the control measures identified in this sheet in order to minimize exposure to respirable crystalline silica. i.e. to apply appropriate protection and prevention measures.

This document should also be made available to persons who may be exposed to respirable crystalline silica in the workplace, in order that they may make the best use of the control measures which are implemented.

This sheet forms part of the Good Practices Guide on silica dust prevention, which is aimed specifically at the control of personal exposure to respirable crystalline silica dust in the workplace.

Access

- ✓ Restrict access to the work area to authorised personnel only.

Design and equipment

- ✓ Ensure that charging equipment is fit for purpose and well maintained.
- ✓ It is preferable to use enclosed handling systems when transporting crystalline silica.
- ✓ Wetting of dry materials may be an alternative to full enclosure.
- ✓ **Pneumatic systems** should be supplied by specialized contractor and special care should be given to the abrasive nature of the crystalline silica.
- ✓ For horizontal transport in **pneumatic systems**, pipes should be angled downwards and have large radius bends where possible to prevent settling in the pipes and causing a blockage in the event system pressure is lost.
- ✓ The pipe work in **pneumatic systems** should be designed to minimise unnecessary obstacles as well as the number of directional changes. Pipe connections should be properly sealed.
- ✓ For **screw conveyors**, the design has to take the abrasive properties of crystalline silica into consideration.
- ✓ **Conveyor belts** should be equipped with cleaning devices. The non-driven pulley should be equipped with a rotation indicator with alarming system.
- ✓ **Loading and unloading points of conveyor belts** should be enclosed when handling dry material. Side seals will prevent spillage. If required filtered vents should be fitted.
- ✓ **Bucket elevators** are suitable for vertical transport, provided they are fully enclosed. It is suggested to equip bucket elevators with plug indicators.
- ✓ **Vibratory feeders** are suitable for horizontal transport of crystalline silica. In case of dry material it is required to have a fully enclosed system.
- ✓ Special attention should be drawn to the design and construction of appropriate **access platforms** to maintenance intensive parts(motors, gear boxes, bearings, belt cleaners, etc.)

Maintenance

- ✓ Ensure that the equipment is maintained, as advised by the supplier, in efficient working order and in good repair.
- ✓ Select machinery with easy access for maintenance.
- ✓ Check conveyor belt cleaning devices on a daily basis and adjust if required.
- ✓ Major damages on conveyor belts should be repaired urgently.
- ✓ On a regular basis, inspect and replace wear parts (belt cleaning devices, bearings, seals etc.) in accordance with the manufacturer's recommendations, in order to reduce potential leaks to a minimum.

Examination and testing

- ✓ Visually check the equipment at least once per week for signs of damage or, if it is in constant use, check it more frequently. If used infrequently, then check it before each use.
- ✓ Keep records of inspections for a suitable period of time which complies with national laws (minimum five years).

Cleaning and housekeeping

- ✓ In order to prevent dust accumulation, clean the workplace on a regular basis.
- ✓ Deal immediately with spills. When dealing with bulk spillages of fine, dry, dusty materials, ensure that cleaning work is undertaken following a written safe working instruction and using the information in this sheet.
- ✓ Use vacuum or wet cleaning methods.
- ✗ **Do not clean up with a dry brush or using compressed air.**

Personal Protective Equipment

- ✓ Refer to task sheet 2.1.15 dedicated to Personal Protective Equipment.
- ✓ Risk assessment could be carried out to determine whether existing controls are appropriate. If necessary, respiratory protective equipment should be provided and worn.
- ✓ If personal protective equipments are required, provide storage facilities to keep them clean when not in use.
- ✓ If respiratory protective equipments are used, they are to be replaced at intervals recommended by its suppliers.

Training

- ✓ Give your employees information on the health effects associated with respirable crystalline silica dust
- ✓ Provide employees with training on: dust exposure prevention; checking controls are working and using them; when and how to use any respiratory protective equipment provided and what to do if something goes wrong. Refer to task sheet 2.1.19 and part 1 of the Good Practice Guide.

Supervision

- ✓ Have a system to check that control measures are in place and that they are being followed. Refer to task sheet 2.1.17.
- ✓ Employers should make sure that employees have all the means to perform the checklist given opposite.

Employee checklist for making the best use of the controls

- ☐ **Make sure the work area is well ventilated and that any dust extraction system are switched on and working correctly.**
- ☐ **Verify proper function of belt cleaning devices. If you notice any anomaly, inform your supervisor**
- ☐ **Immediately cleaning up bulk spillages of fine, dry dusty materials by using vacuum or wet cleaning methods. Ensure that you work in accordance with your Company's written safe working instruction.**
- ☐ **Inform your supervisor immediately in case of leakage.**
- ☐ **Use maintain and store any person protective equipment provided in accordance with instructions**

2.1.12

Laboratory work

This sheet provides guidance on the control measures to be used in a laboratory environment in order to control laboratory workers' exposure to respirable crystalline silica dust in the workplace.

This guidance sheet is aimed at employers to help them comply with the requirements of workplace health and safety legislation, by controlling exposure to respirable crystalline silica.

Specifically, this sheet provides advice on control measures that may be used in laboratories. Following the key points of this task sheet will help reduce exposure. Depending on the specific circumstances of each case, it may not be necessary to apply all of the control measures identified in this sheet in order to minimize exposure to respirable crystalline silica. i.e. to apply appropriate protection and prevention measures.

This document should also be made available to persons who may be exposed to respirable crystalline silica in the workplace, in order that they may make the best use of the control measures which are implemented.

This sheet forms part of the Good Practices Guide on silica dust prevention, which is aimed specifically at the control of personal exposure to respirable crystalline silica dust in the workplace.

Access

- ✓ Restrict access to the work area to authorised personnel only.

Design and equipment

- ✓ Laboratories should have their own, clean air supply and they should be sealed and physically separated from any adjacent dusty areas.
- ✓ Use flooring surfaces and furniture that are easy to keep clean and that do not absorb dust. Use solid floors (rather than grid/mesh) and seal them with a wear resistant material which is coloured to highlight dust contamination.
- ✓ Provide local exhaust ventilation systems for specific laboratory test equipment which may cause airborne dust generation.
- ✓ Grinding equipment is available with an integrated exhaust ventilation system.
- ✓ The use of fume cupboards may be appropriate when handling samples of silica flour and other similar materials.
- ✓ Wherever possible, use wet cleaning methods when cleaning items of laboratory test equipment.
- ✓ Store samples in a dedicated store room outside the main laboratory area.
- ✓ Provide facilities, including notice boards, for the communication of health and safety information, safe working procedures etc.

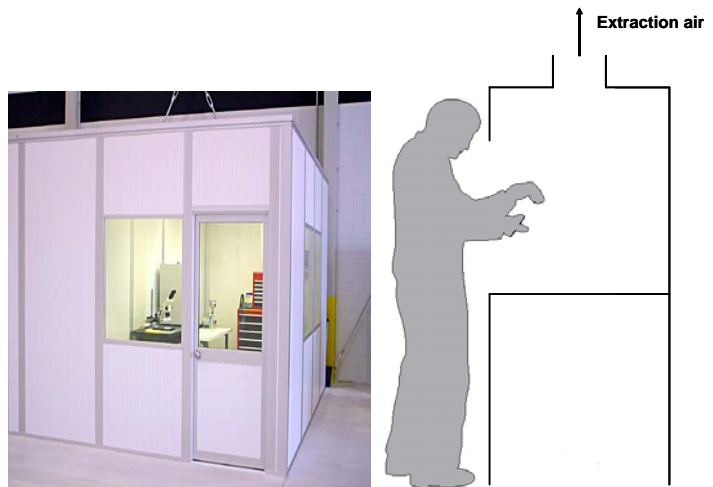

Maintenance

- ✓ Maintain laboratory equipment and all equipment provided for dust control as advised by the supplier/installer.

Examination and testing

- ✓ Check the condition and the performance of all dust control equipment at least once per week for signs of damage or reduced efficiency. If it is in constant use, check it more frequently. If used infrequently, then check it before each use.
- ✓ Have dust control equipment tested against its performance standard in compliance with local legal requirements, at a frequency which meets with manufacturers' recommendations and which complies with the outcome of a risk assessment.
- ✓ Keep records of inspections for a suitable period of time which complies with national laws (minimum five years).

Cleaning and housekeeping

- ✓ Clean floors and other surfaces regularly.
- ✗ **Do not clean up with a dry brush or using compressed air.**
- ✓ Use vacuum or wet cleaning methods.

Personal Protective Equipment

- ✓ Refer to task sheet 2.1.15 dedicated to Personal Protective Equipment.
- ✓ Indicate areas where personal protective equipment (e.g. dust masks) must be worn using appropriate signs.
- ✓ Provide storage facilities to keep personal protective equipment clean when not in use.
- ✓ Provide adequate supplies of personal protective equipment. Ensure that it is readily obtainable. Identify the locations of these supplies using appropriate signs

Training

- ✓ Give your employees information on the health effects associated with respirable crystalline silica dust
- ✓ Provide employees with training on: dust exposure prevention; checking controls are working and using them; when and how to use any respiratory protective equipment provided and what to do if something goes wrong. Refer to task sheet 2.1.19 and part 1 of the Good Practice Guide.

Supervision

- ✓ Have a system to check that control measures are in place and that they are being followed. Refer to task sheet 2.1.17.
- ✓ Employers should make sure that employees have all the means to perform the checklist given opposite.

Employee checklist for making the best use of the controls

- ☐ **Keep laboratories clean in order to prevent dust being stirred up.**
- ☐ **For dry dusts, use vacuum or wet cleaning methods.**
- ☐ **Keep doors and windows closed to prevent dust entering.**
- ☐ **Remember that airborne respirable crystalline silica dust cannot be seen with the naked eye. However, an accumulation of fine dust on surfaces inside the laboratory may indicate that dust control measures are not working correctly.**
- ☐ **Look for signs of damage, wear or poor operation of any equipment used. If you find any problems, tell your supervisor. Do not carry on working if you think there is a problem.**
- ☐ **If you think there is a problem with your dust control equipment, ensure additional control measures are taken to reduce exposure to respirable crystalline silica dust while the problem persists.**

2.1.13

Local exhaust ventilation

This sheet provides general advice on the points to cover in contracts to design, install and commission new local exhaust ventilation equipment to control airborne contaminants. This task sheet should be read in conjunction with the task sheets entitled "Design of ducting", "Design of dust extraction units" and "General ventilation".

This guidance sheet is aimed at employers to help them comply with the requirements of workplace health and safety legislation, by controlling exposure to respirable crystalline silica.

Specifically, this sheet provides advice on dust control during the design and use of local exhaust ventilation in the workplace. Following the key points of this task sheet will help reduce exposure. Depending on the specific circumstances of each case, it may not be necessary to apply all of the control measures identified in this sheet in order to minimize exposure to respirable crystalline silica. i.e. to apply appropriate protection and prevention measures.

This document should also be made available to persons who may be exposed to respirable crystalline silica in the workplace, in order that they may make the best use of the control measures which are implemented.

This sheet forms part of the Good Practices Guide on silica dust prevention, which is aimed specifically at the control of personal exposure to respirable crystalline silica dust in the workplace.



Access

- ✓ Restrict access to the work area to authorised personnel only.

Design and equipment

- ✓ Use a reputable supplier of off-the-shelf Local exhaust ventilation. Contact only qualified engineers to quote for the work.
- ✓ The designer needs to know what the contaminant is and how it is produced. Contaminants leading to possible dust explosion should have special attention.
- ✓ The design must have the following elements: a hood, enclosure or other inlet to collect and contain the contaminant; ducts to remove the contaminant away from the source; a filter or other air cleaning device, normally placed between the hood and the fan; a fan or other air mover to provide the airflow; more ducting to discharge the cleaned air outside out or in the workplace.
- ✓ Apply local exhaust ventilation at the source of generation to capture the dust.
- ✓ Enclose the dust source as much as possible to help prevent it spreading.
- ✓ Local exhaust ventilation should be connected to a suitable dust extraction unit (e.g. a bag filter/cyclone).
- ✗ Don't allow workers to get between the source of exposure and the local exhaust ventilation, otherwise they will be directly in the path of the contaminated air flow.
- ✓ Where possible, site the work area away from doors, windows and walkways to stop draughts interfering with the local exhaust ventilation and spreading the dust.
- ✓ Have a clean air supply coming into the work area to replace extracted air.
- ✓ Keep ducts short and simple and avoid long sections of flexible duct.
- ✓ Provide an easy way of checking the local exhaust ventilation is working e.g. manometer, pressure gauge or tell-tale.
- ✓ Discharge extracted air to a safe place away from doors, windows and air inlets. However, if necessary, clean, filtered air can be re-circulated into the workroom, provided systems are in place to check the effectiveness of the filter. Quantities of recirculated air should be in compliance with existing standards and regulations.

The design and specification of ventilation systems may need to be approved under national regulations.

Maintenance

- ✓ Maintain the local exhaust ventilation as advised by the supplier/installer in efficient working order and in good repair. Noisy and vibrating fans can indicate a problem.
- ✓ Replace consumables (filters etc) in accordance with the manufacturer's recommendations.
- ✓ Never modify any part of the system. If you do so, check with the supplier and see that the system maintains its CE label

Examination and testing

- ✓ You must receive instructions for use and a diagram of the new system. You must receive a commissioning report that shows the airflows at all inlets, air speeds in the ducts, the pressure drop across the cleaner or filter
- ✓ Obtain information on the design performance of the local exhaust ventilation from the supplier. Keep this information to compare with future test results.
- ✓ Visually check the local exhaust ventilation and visible ducting at least once per week for signs of damage. If it is in constant use, check it more frequently. If used infrequently, then check it before each use.
- ✓ Have the local exhaust ventilation examined and tested against its performance standard in compliance with local legal requirements, at a frequency which meets with manufacturers' recommendations and which complies with the outcome of a risk assessment.
- ✓ Keep records of inspections for a suitable period of time which complies with national laws (minimum five years).

Cleaning and housekeeping

- ✓ Clean work area daily.
- ✓ Deal with spills immediately.
- ✗ **Do not clean up with a dry brush or using compressed air.**
- ✓ Use vacuum or wet cleaning methods.

Personal Protective Equipment

- ✓ Refer to task sheet 2.1.15 dedicated to Personal Protective Equipment.
- ✓ Risk assessment must be carried out to determine whether existing controls are adequate. If necessary, respiratory protective equipment (with the appropriate protection factor) should be provided and worn.
- ✓ Provide storage facilities to keep personal protective equipment clean when not in use.
- ✓ Replace respiratory protective equipment at intervals recommended by its suppliers.

Training

- ✓ Give your employees information on the health effects associated with respirable crystalline silica dust
- ✓ Provide employees with training on: dust exposure prevention; checking controls are working and using them; when and how to use any respiratory protective equipment provided and what to do if something goes wrong. Refer to task sheet 2.1.19 and part 1 of the Good Practice Guide.

Supervision

- ✓ Have a system to check that control measures are in place and that they are being followed. Refer to task sheet 2.1.17.
- ✓ Follow instructions in the manufacturer's manual
- ✓ Employers should make sure that employees have all the means to perform the checklist given opposite.

Employee checklist for making the best use of the controls

- ☐ **Make sure the local exhaust ventilation is switched on and is working.**
- ☐ **Make sure it is working properly and check the manometer, pressure gauge or telltale.**
- ☐ **Look for signs of damage, wear or poor operation of any equipment used. If you find any problems, tell your supervisor.**
- ☐ **If you think there is a problem with your dust control equipment, ensure additional control measures are taken to reduce exposure to respirable crystalline silica dust while the problem persists.**
- ☐ **Make sure that paper bags and other waste are not drawn into the local exhaust ventilation.**
- ☐ **Don't position yourself between the source of exposure and the local exhaust ventilation. If you cannot avoid this, discuss how to overcome the problem with your supervisor.**
- ☐ **Clear up spills straight away.**
- ☐ **Clean up using vacuum or wet cleaning methods.**
- ☐ **Use, maintain and store any respiratory protective equipment provided in accordance with instructions.**

2.1.14

Maintenance, Service & Repair Activities

This sheet provides guidance on activities connected with maintaining, servicing and repairing plant and equipment that may cause the generation of respirable crystalline silica.

This guidance sheet is aimed at employers and contractors to help them comply with the requirements of workplace health and safety legislation, by controlling exposure to respirable crystalline silica in the work place.

Specifically, this sheet provides advice on minimising exposure to respirable silica during maintenance, service, and repairs, including breakdowns. Following the key points of this task sheet will help reduce exposure.

Depending on the specific circumstances of each task or work activity, it may not be necessary to apply all of the control measures identified in this sheet in order to minimize exposure to respirable crystalline silica.

i.e. to apply appropriate protection and prevention measures.

This document should be made available to persons who may be exposed to respirable crystalline silica in the workplace, in order that they may make the best use of the control measures which are implemented.

This sheet forms part of the Good Practices Guide on silica dust prevention, which is aimed specifically at the control of personal exposure to respirable crystalline silica in the workplace.

Note:-

Besides the possible exposure to respirable silica dust, other hazards may present a greater danger to maintenance workers and need to be considered prior to commencement of work, - **these include:-**

- **Work at height**
- **Moving machinery**
- **Excessive noise**
- **Confined spaces**
- **Welding, burning, cutting & grinding**

Access

Restrict access to the work area to authorised personnel only.

Nature of Maintenance, Service and Repair Work

It is typical for employees and contractors such as fitters, electricians, patrolmen and labourers, to be employed in the following types of work (non-exhaustive list)

- ✓ Daily Planned Preventive Maintenance / Service / Repair. e.g. Lubrication, Visual walk through inspections, House keeping
- ✓ Routine Planned Preventive Maintenance / Service / Repair. E.g. change screen decks, filter bags, liner plates and undertake calibrations
- ✓ Breakdowns and Emergencies. E.g. failed drive motors, V-belts, power failure and blockages.

Under Taking The Work

When undertaking maintenance, service and repair work, the task needs to be considered in relation to each of the following criteria, so as to minimise the risk of personal exposure to respirable crystalline silica:-

- ✓ Competence of employees / contractors
- ✓ Risk Assessments completed
- ✓ Safe Working Procedures (including permits to work and local rules, if applicable)
- ✓ Inductions for contractors
- ✓ Equipment used In the task or work is maintained in efficient working order and suitable for the work in hand
- ✓ Personal protective equipment arrangements
- ✓ Measures for the control of hazardous substances
- ✓ Provision of a monitoring strategy
- ✓ Supervision
- ✓ Emergency arrangements
- ✓ Waste disposal

Examination and testing

- ✓ Check effectiveness of respiratory protective equipment before use
- ✓ Keep records of inspections for a suitable period of time which complies with national laws (minimum five years).
- ✓ Ensure local exhaust ventilation is effective and regularly tested

Cleaning and housekeeping

- ✓ Maintain good housekeeping standards
- ✓ Where possible, clean up around work area before start of work
- ✗ **Do not clean up with a dry brush or using compressed air.**
- ✓ Use vacuum or wet cleaning methods.

Personal Protective Equipment

- ✓ Refer to task sheet 2.1.15 dedicated to Personal Protective Equipment.
- ✓ Risk assessment must be carried out to determine whether existing controls are adequate. If necessary, respiratory protective equipment (with the appropriate protection factor) should be provided and worn.
- ✓ Provide storage facilities to keep personal protective equipment clean when not in use. Replace respiratory protective equipment at intervals recommended by its suppliers.
- ✓ Note that facial hair will reduce the effectiveness of a dust mask. Operators with facial hair should be provided with air fed respirators or similar alternatives

Training

- ✓ Give your employees information on the health effects associated with respirable crystalline silica dust
- ✓ Provide employees with training on: dust exposure prevention; checking controls are working and using them; when and how to use any respiratory protective equipment provided and what to do if something goes wrong. Refer to task sheet 2.1.19 and part 1 of the Good Practice Guide.

Supervision

- ✓ Have a system to check that control measures are in place and that they are being followed. Refer to task sheet 2.1.17.
- ✓ Employers should make sure that employees have all the means to perform the checklist given opposite.

Employee checklist for making the best use of the controls

- ☐ **Ensure all plant and equipment isolated from power source before attempting work e.g. electrics, pneumatics, hydraulics, stored energy**
- ☐ **Make sure enclosed areas are well ventilated and any dust extraction system is switched on and is working.**
- ☐ **Look for signs of damage, wear or poor operation of any equipment used. If you find any problems, tell your supervisor.**
- ☐ **If you think there is a problem with your dust control equipment, ensure additional control measures are taken to reduce exposure to respirable crystalline silica dust while the problem persists.**
- ☐ **Provide belt scrapers to conveyors to minimise spillage.**
- ☐ **Provide dust containment covers for screens, conveyors and crushers.**
- ☐ **Clean up enclosed areas using vacuum or wet cleaning methods.**
- ☐ **Use best available techniques when designing and installing new plant & equipment**
- ☐ **Use, maintain and store any respiratory protective equipment provided in accordance with instructions.**

2.1.14a

Dry cutting of slits using electric wall chasers

This sheet provides good practice guidance for dry cutting of slits in concrete containing crystalline silica by electric wall chasers.

This guidance sheet is aimed at employers to help them comply with the requirements of workplace health and safety legislation, by controlling exposure to respirable crystalline silica.

Specifically, this sheet provides good practice guidance for dry cutting of slits in concrete containing crystalline silica by electric wall chasers. Following the key points of this task sheet will help reduce exposure. Depending on the specific circumstances of each case, it may not be necessary to apply all of the control measures identified in this sheet in order to reduce exposure.

This document should also be made available to persons who may be exposed to respirable crystalline silica in the workplace, in order that they may make the best use of the control measures which are implemented.

This sheet forms part of the Good Practices Guide on silica dust prevention, which is aimed specifically at the control of personal exposure to respirable crystalline

Access

- ✓ Restrict access to the work area to authorised personnel only.

Design and equipment

- ✓ Choose the right system of tool and dust extraction unit for your job.
- ✓ The dust extraction unit may be a separate unit or an integrated one.
- ✓ Work only with a connected dust extraction unit. Ensure that your extraction unit always works correctly.
- ✓ The dust extraction unit has to fulfil at least the requirements of dust-class M according to EN 60335-2-69.
NOTE: For more information about the suitability of dust-class M for minerals dust see:
<http://www.gisbau.de/service/sonstiges/staub/staub.htm>
- ✓ Ensure that all settings of the dust collection equipment are made in accordance with the instruction manuals of the tool and extraction unit.

Maintenance

- ✓ Maintain the equipment in accordance with the instruction manuals, to keep them in efficient working order and good repair.



Examination and testing

- ✓ Visually check of the tool and extraction unit for signs of damage before every use.
- ✓ Make sure that the system of tool and dust extraction unit operates correct.
- ✓ Keep records of inspections for a suitable period of time which complies with national laws (minimum five years).

Cleaning and housekeeping

- ✓ Clean the equipment regularly according to the recommendations of the manufacturer.
- ✓ Use vacuum or wet cleaning methods.
- x Do not clean the work area with a dry brush or using compressed air.

Personal Protective Equipment

- ✓ Refer to task sheet 2.1.15 dedicated to Personal Protective Equipment.
- ✓ Indicate areas where personal protective equipment must be worn.
- ✓ Provide storage facilities to keep personal protective equipment clean when not in use.
- ✓ Replace respiratory protective equipment at intervals recommended by its suppliers.
- ✓ Risk assessment could be carried out to determine whether existing controls are appropriate.

Training

- ✓ Give your employees information on the health effects associated with respirable crystalline silica dust.
- ✓ Provide employees with training on: dust exposure prevention; checking controls are working and using them; when and how to use any respiratory protective equipment provided and what to do if something goes wrong. Refer to task sheet 2.1.19 and part 1 of the Good Practice Guide.

Supervision

- ✓ Have a system to check that control measures are in place and that they are being followed. Refer to task sheet 2.1.17.
- ✓ Employers should make sure that employees have all the means to perform the checklist given opposite.

Employee checklist for making the best use of the controls

- Make sure the room is well ventilated and any dust extraction system is switched on and is working.
- Look for signs of damage, wear or poor operation of any equipment used. If you find any problems, tell your supervisor. If using diamond blades, ensure they are not worn down, cracked or damaged in any way.
- If you think there is a problem with your dust control equipment, ensure additional control measures are taken to reduce exposure to respirable crystalline silica dust while the problem persists.
- Do not interface with ventilation systems – they are provided to protect your working environment.
- Clean up using vacuum or wet cleaning methods.
- Use, maintain and store any respiratory protective equipment provided in accordance with instructions.

2.1.14b

Dry cutting and grinding applications using hand-held angle grinders/cutters

This sheet provides guidance for dry cutting & grinding applications on concrete containing crystalline silica with hand-held electric angle grinders, angle cutters and cut-off machines.

This guidance sheet is aimed at employers to help them comply with the requirements of workplace health and safety legislation, by controlling exposure to respirable crystalline silica.

Specifically, this sheet provides good practice guidance for dry cutting & grinding applications on concrete containing crystalline silica with hand-held electric angle grinders, angle cutters and cut-off machines. Following the key points of this task sheet will help reduce exposure. Depending on the specific circumstances of each case, it may not be necessary to apply all of the control measures identified in this sheet in order to reduce exposure.

This document should also be made available to persons who may be exposed to respirable crystalline silica in the workplace, in order that they may make the best use of the control measures which are implemented.

This sheet forms part of the Good Practices Guide on silica dust prevention, which is aimed specifically at the control of personal exposure to respirable crystalline

Access

- ✓ Restrict access to the work area to authorised personnel only.

Design and equipment

- ✓ Ensure that your tool has the facility to connect a dust extraction.
- ✓ Choose the right system of tool and dust extraction unit for your job.
- ✓ Work only with a connected dust extraction unit. Ensure that your extraction unit always works correctly.
- ✓ The dust extraction unit has to fulfil at least the requirements of dust-class M according to EN 60335-2-69.
NOTE: For more information about the suitability of dust-class M for minerals dust see:
<http://www.gjsbau.de/service/sonstiges/staub/staub.htm>
- ✓ Ensure that all settings of the dust collection equipment are made in accordance with the instruction manuals of the tool and extraction unit.

Maintenance

- ✓ Maintain the equipment in accordance with the instruction manuals, to keep them in efficient working order and good repair.



Examination and testing

- ✓ Visually check of the tool and extraction unit for signs of damage before every use.
- ✓ Make sure that the system of tool and dust extraction unit operates correct.
- ✓ Keep records of inspections for a suitable period of time which complies with national laws (minimum five years).

Cleaning and housekeeping

- ✓ Clean the equipment regularly according to the recommendations of the manufacturer.
- ✓ Use vacuum or wet cleaning methods.
- x Do not clean the work area with a dry brush or using compressed air.

Personal Protective Equipment

- ✓ Refer to task sheet 2.1.15 dedicated to Personal Protective Equipment.
- ✓ Indicate areas where personal protective equipment must be worn.
- ✓ Provide storage facilities to keep personal protective equipment clean when not in use.
- ✓ Replace respiratory protective equipment at intervals recommended by its suppliers.
- ✓ Risk assessment could be carried out to determine whether existing controls are appropriate.

Training

- ✓ Give your employees information on the health effects associated with respirable crystalline silica dust.
- ✓ Provide employees with training on: dust exposure prevention; checking controls are working and using them; when and how to use any respiratory protective equipment provided and what to do if something goes wrong. Refer to task sheet 2.1.19 and part 1 of the Good Practice Guide.

Supervision

- ✓ Have a system to check that control measures are in place and that they are being followed. Refer to task sheet 2.1.17.
- ✓ Employers should make sure that employees have all the means to perform the checklist given opposite.

Employee checklist for making the best use of the controls

- Make sure the room is well ventilated and any dust extraction system is switched on and is working.
- Look for signs of damage, wear or poor operation of any equipment used. If you find any problems, tell your supervisor. If using diamond blades, ensure they are not worn down, cracked or damaged in any way.
- If you think there is a problem with your dust control equipment, ensure additional control measures are taken to reduce exposure to respirable crystalline silica dust while the problem persists.
- Do not interface with ventilation systems – they are provided to protect your working environment.
- Clean up using vacuum or wet cleaning methods.
- Use, maintain and store any respiratory protective equipment provided in accordance with instructions.

2.1.14c

Dry grinding of concrete using electric concrete surface grinders

This sheet provides guidance for dry grinding of concrete containing crystalline silica by electric concrete surface grinders.

This guidance sheet is aimed at employers to help them comply with the requirements of workplace health and safety legislation, by controlling exposure to respirable crystalline silica.

Specifically, this sheet provides good practice guidance for dry grinding of concrete using electric concrete surface grinders. Following the key points of this task sheet will help reduce exposure. Depending on the specific circumstances of each case, it may not be necessary to apply all of the control measures identified in this sheet in order to reduce exposure.

This document should also be made available to persons who may be exposed to respirable crystalline silica in the workplace, in order that they may make the best use of the control measures which are implemented.

This sheet forms part of the Good Practices Guide on silica dust prevention, which is aimed specifically at the control of personal exposure to respirable crystalline

Access

- ✓ Restrict access to the work area to authorised personnel only.

Design and equipment

- ✓ Choose the right system of tool and dust extraction unit for your job.
- ✓ The dust extraction unit may be a separate unit or an integrated one.
- ✓ Work only with a connected dust extraction unit. Ensure that your extraction unit always works correctly.
- ✓ The dust extraction unit has to fulfil at least the requirements of dust-class M according to EN 60335-2-69.
NOTE: For more information about the suitability of dust-class M for minerals dust see:
<http://www.gisbau.de/service/sonstiges/staub/staub.htm>
- ✓ Ensure that all settings of the dust collection equipment are made in accordance with the instruction manuals of the tool and extraction unit.

Maintenance

- ✓ Maintain the equipment in accordance with the instruction manuals, to keep them in efficient working order and good repair.

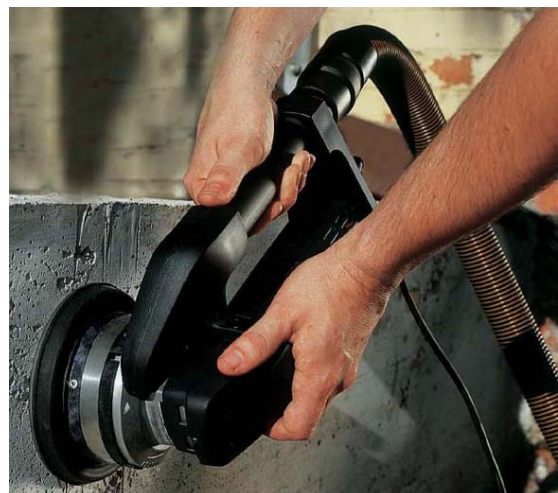

Examination and testing

- ✓ Visually check of the tool and extraction unit for signs of damage before every use.
- ✓ Make sure that the system of tool and dust extraction unit operates correct.
- ✓ Keep records of inspections for a suitable period of time which complies with national laws (minimum five years).

Cleaning and housekeeping

- ✓ Clean the equipment regularly according to the recommendations of the manufacturer.
- ✓ Use vacuum or wet cleaning methods.
- x Do not clean the work area with a dry brush or using compressed air.

Personal Protective Equipment

- ✓ Refer to task sheet 2.1.15 dedicated to Personal Protective Equipment.
- ✓ Indicate areas where personal protective equipment must be worn.
- ✓ Provide storage facilities to keep personal protective equipment clean when not in use.
- ✓ Replace respiratory protective equipment at intervals recommended by its suppliers.
- ✓ Risk assessment could be carried out to determine whether existing controls are appropriate.

Training

- ✓ Give your employees information on the health effects associated with respirable crystalline silica dust.
- ✓ Provide employees with training on: dust exposure prevention; checking controls are working and using them; when and how to use any respiratory protective equipment provided and what to do if something goes wrong. Refer to task sheet 2.1.19 and part 1 of the Good Practice Guide.

Supervision

- ✓ Have a system to check that control measures are in place and that they are being followed. Refer to task sheet 2.1.17.
- ✓ Employers should make sure that employees have all the means to perform the checklist given opposite.

Employee checklist for making the best use of the controls

- Make sure the room is well ventilated and any dust extraction system is switched on and is working.
- Look for signs of damage, wear or poor operation of any equipment used. If you find any problems, tell your supervisor.
- If you think there is a problem with your dust control equipment, ensure additional control measures are taken to reduce exposure to respirable crystalline silica dust while the problem persists.
- Do not interface with ventilation systems – they are provided to protect your working environment.
- Clean up using vacuum or wet cleaning methods.
- Use, maintain and store any respiratory protective equipment provided in accordance with instructions.

2.1.14d

Dry sanding activities using hand-held electric power tools

This sheet provides guidance for dry sanding materials containing crystalline silica with hand-held electric power tools like orbital sanders, random orbital sanders (eccentric sanders), belt sanders.

This guidance sheet is aimed at employers to help them comply with the requirements of workplace health and safety legislation, by controlling exposure to respirable crystalline silica.

Specifically, this sheet provides guidance for dry sanding materials containing crystalline silica with hand-held electric power tools like orbital sanders, random orbital sanders (eccentric sanders), belt sanders. Following the key points of this task sheet will help reduce exposure. Depending on the specific circumstances of each case, it may not be necessary to apply all of the control measures identified in this sheet in order to reduce exposure.

This document should also be made available to persons who may be exposed to respirable crystalline silica in the workplace, in order that they may make the best use of the control measures which are implemented.

This sheet forms part of the Good Practices Guide on silica dust prevention, which is aimed specifically at the control of personal exposure to respirable crystalline

Access

- ✓ Restrict access to the work area to authorised personnel only.

Design and equipment

- ✓ Choose the right system of tool and dust extraction unit for your job.
- ✓ The dust extraction unit may be integrated in the tool or a separate unit.
- ✓ Work only with a connected dust extraction unit. Ensure that your extraction unit always works correctly.
- ✓ The dust extraction unit has to fulfil at least the requirements of dust-class M according to EN 60335-2-69. NOTE: For more information about the suitability of dust-class M for minerals dust see: <http://www.gisbau.de/service/sonstiges/staub/staub.htm>
- ✓ Ensure that all settings of the dust collection equipment are made in accordance with the instruction manuals of the tool and extraction unit.

Maintenance

- ✓ Maintain the equipment in accordance with the instruction manuals, to keep them in efficient working order and good repair.

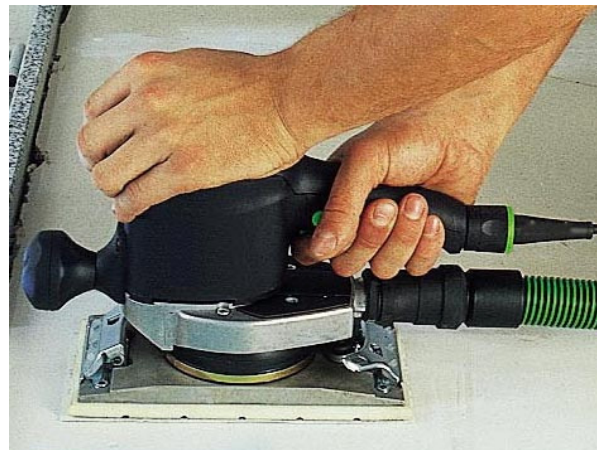

Examination and testing

- ✓ Visually check of the tool and extraction unit for signs of damage before every use.
- ✓ Make sure that the system of tool and dust extraction unit operates correct.
- ✓ Keep records of inspections for a suitable period of time which complies with national laws (minimum five years).

Cleaning and housekeeping

- ✓ Clean the equipment regularly according to the recommendations of the manufacturer.
- ✓ Use vacuum or wet cleaning methods.
- x Do not clean the work area with a dry brush or using compressed air.

Personal Protective Equipment

- ✓ Refer to task sheet 2.1.15 dedicated to Personal Protective Equipment.
- ✓ Indicate areas where personal protective equipment must be worn.
- ✓ Provide storage facilities to keep personal protective equipment clean when not in use.
- ✓ Replace respiratory protective equipment at intervals recommended by its suppliers.
- ✓ Risk assessment could be carried out to determine whether existing controls are appropriate.

Training

- ✓ Give your employees information on the health effects associated with respirable crystalline silica dust.
- ✓ Provide employees with training on: dust exposure prevention; checking controls are working and using them; when and how to use any respiratory protective equipment provided and what to do if something goes wrong. Refer to task sheet 2.1.19 and part 1 of the Good Practice Guide.

Supervision

- ✓ Have a system to check that control measures are in place and that they are being followed. Refer to task sheet 2.1.17.
- ✓ Employers should make sure that employees have all the means to perform the checklist given opposite.

Employee checklist for making the best use of the controls

- Make sure the room is well ventilated and any dust extraction system is switched on and is working.
- Look for signs of damage, wear or poor operation of any equipment used. If you find any problems, tell your supervisor.
- If you think there is a problem with your dust control equipment, ensure additional control measures are taken to reduce exposure to respirable crystalline silica dust while the problem persists.
- Do not interface with ventilation systems – they are provided to protect your working environment.
- Clean up using vacuum or wet cleaning methods.
- Use, maintain and store any respiratory protective equipment provided in accordance with instructions.

Personal protective equipment (PPE)

This activity covers the use and maintenance of PPE for workers exposed to respirable crystalline silica dust.

The use of PPE should be seen as a last resort, to be used only when all reasonable engineering and organisational control measures have been implemented and have failed to provide adequate control of exposure.

This guidance sheet is aimed at employers to help them comply with the requirements of workplace health and safety legislation, by controlling exposure to respirable crystalline silica.

Specifically, this sheet provides advice on the use and maintenance of personal protective equipment (PPE). Following the key points of this task sheet will help reduce exposure

Depending on the specific circumstances of each case, it may not be necessary to apply all of the control measures identified in this sheet in order to minimize exposure to respirable crystalline silica. i.e. to apply appropriate protection and prevention measures.

This document should also be made available to persons who may be exposed to respirable crystalline silica in the workplace, in order that they may make the best use of the control measures which are implemented.

This sheet forms part of the Good Practices Guide on silica dust prevention, which is aimed specifically at the control of personal exposure to respirable crystalline silica dust in the workplace.

Access

- ✓ Restrict access to the work area to authorised personnel only. Work areas where the use of personal protective equipment is mandatory should be clearly demarcated through the provision of appropriate signage.

Design and equipment

- ✓ Personal protective equipment must comply with the relevant Community provisions on design and manufacture with respect to safety and health. All personal protective equipment must be provided by the company and it must carry a CE mark.
- ✓ Where PPE is used, a programme should be established covering all aspects of the selection, use and maintenance of the equipment.
- ✓ PPE should be selected on the basis of performance (eg protection factor), comfort and durability.
- ✓ Where it is necessary to wear more than one item of PPE, ensure that those items are compatible with each other.
- ✓ Protective clothes (overalls) must be used during all dusty tasks. Dark colours may be used to help indicate dust contamination. Your workwear supplier will be able to advise you of appropriate clothing
- ✓ Use the pictograms below in the workplace to explain where the use of PPE is required.



Respiratory mask



Ear protection



Eye protection



Safety helmet



Protective clothes

Maintenance

- ✓ Ensure equipment used in the task is maintained as advised by the supplier in efficient working order and in good repair.
- ✓ Protective clothes (overalls) should not be taken home. They should be cleaned by the employer.

Examination and testing

- ✓ Visually check PPE daily for signs of damage. If used infrequently, then check it before each use.
- ✓ Check effectiveness of respiratory protective equipment before use. Seek advice from the supplier on appropriate fit testing methods.
- ✓ Keep records of inspections for a suitable period of time which complies with national laws (minimum five years).

Cleaning and housekeeping

- ✓ Keep non-disposable items of PPE clean.
- ✓ Employers must provide clean storage facilities for PPE.
- ✗ **Do not clean clothing using compressed air.**
- ✓ Use vacuum or wet cleaning methods.

Respiratory Protective Equipment

- ✓ Risk assessment must be carried out to determine whether existing controls are adequate. If necessary, respiratory protective equipment (with the appropriate protection factor) should be provided and worn. Equipment should be selected that is compatible with other items of personal protective equipment e.g. ear defenders, goggles, welding visors.
- ✓ Ensure that the operator achieves the essential face seal with the selected mask. This can be checked using simple testing methods e.g. a mist of sugar solution can be dispersed in the air to check if the operator tastes it. If so there is evidence of leakage.
- ✓ Note that facial hair will reduce the effectiveness of a dust mask. Operators with facial hair should be provided with air fed respirators or other suitable alternative.
- ✓ Provide storage facilities to keep personal protective equipment clean when not in use.
- ✓ For each work activity, make an assessment to determine how frequently respiratory protective equipment should be replaced in order to guarantee its effectiveness. Replace respiratory protective equipment at intervals recommended by its suppliers.

Training

- ✓ Give your employees information on the health effects associated with respirable crystalline silica dust
- ✓ Provide employees with training on: dust exposure prevention; checking controls are working and using them; when and how to use any respiratory protective equipment provided and what to do if something goes wrong. Refer to task sheet 2.1.19 and part 1 of the Good Practice Guide.

Supervision

- ✓ Have a system to check that control measures are in place and that they are being followed. Refer to task sheet 2.1.17.
- ✓ Employers should make sure that employees have all the means to perform the checklist given opposite.

Employee checklist for making the best use of the controls

- ☐ **Look for signs of damage, wear or poor operation of any equipment used. If you find any problems, tell your supervisor.**
- ☐ **Even if you do not normally wear respiratory protective equipment, it may be necessary for you to wear it temporarily in the event other control measures fail.**
- ☐ **Use, maintain and store any personal protective equipment provided in accordance with instructions.**
- ☐ **Adjust your PPE so that it fits you correctly.**
- ☐ **If you have facial hair, this could reduce the effectiveness of a dust mask. Select an appropriate air fed respirator or suitable alternative.**
- ☐ **When it is necessary for you to wear more than one item of PPE, ensure that all items are compatible with each other.**

Removing dust or sludge from an extraction unit

This guidance sheet is to be read in conjunction with the sheets entitled "Design of ducting", "Design of dust extraction units" and "General ventilation".

This guidance sheet is aimed at employers to help them comply with the requirements of workplace health and safety legislation, by controlling exposure to respirable crystalline silica.

Specifically, this sheet provides advice on safe working procedures for use when removing dust from an extraction unit. Following the key points of this task sheet will help reduce exposure.

Depending on the specific circumstances of each case, it may not be necessary to apply all of the control measures identified in this sheet in order to minimize exposure to respirable crystalline silica. i.e. to apply appropriate protection and prevention measures.

This document should also be made available to persons who may be exposed to respirable crystalline silica in the workplace, in order that they may make the best use of the control measures which are implemented.

This sheet forms part of the Good Practices Guide on silica dust prevention, which is aimed specifically at the control of personal exposure to respirable crystalline silica dust in the workplace.

Access

- ✓ Restrict access to the work area to authorised personnel only. Place warning signs.
- ✓ Provide good access to enable safe removal of possibly hazardous wet or dry wastes.

Design and equipment

- ✓ Where possible, the dust extraction should be located away from draughts and the prevailing wind, and outside the working area.
- ✓ Consider the need for explosion relief for combustible solids and ensure that equipment is appropriately earthed.
- ✓ The design should take the possible abrasiveness of the dust into account
- ✓ Ensure that the collected dust is deposited in a sealed container e.g. a skip or bin. Consider using an inner liner.
- ✓ Wet collectors and scrubbers require scraping free of sludge and scale
- ✓ Determine the periodicity required for emptying the waste bin.
- ✓ Consider how the bin will be moved for emptying and provide help if necessary.
- ✓ If necessary, clean and filtered air can be reintroduced into the work area.
- ✓ Quantities of recirculated air should be in compliance with existing standards and regulations.
- ✓ The design and specification of extraction systems may need to be approved by national standards and regulations.

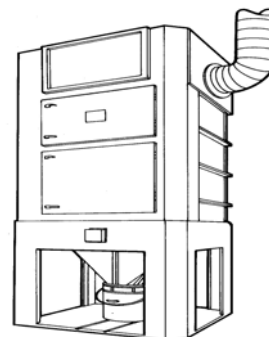

Maintenance

- ✓ Keep equipment in effective and efficient working order.
- ✓ Follow instructions in maintenance manuals and define the PPE necessary during this maintenance
- ✓ Keep airline oil free, water taps empty and filters clean
- ✓ Replace consumables (filters etc) in accordance with the manufacturer's recommendations.

Examination and testing

- ✓ Check water levels in a wet scrubber reservoir
- ✓ Obtain information on the design performance of the extraction unit from the supplier. Keep this information to compare with future test results.
- ✓ Visually check associated ventilation equipment (f.e. compressed airlines) at least once per week for signs of damage. If it is in constant use, check it more frequently. If used infrequently, then check it before each use.
- ✓ Have the associated ventilation equipment examined and tested against its performance standard, at least once each year.
- ✓ Find out the hazardous properties of your baghouse and/or scrubber residues
- ✓ Keep records of inspections for a suitable period of time which complies with national laws (minimum five years).

Cleaning and housekeeping

- ✓ Clean the work area daily.
- ✓ Workers should handle the residues carefully- some dry residues may catch fire
- ✓ Ensure the waste bin is emptied regularly and make sure it does not overflow.
- ✓ Deal with spills immediately.
- ✗ **Do not clean up with a dry brush or using compressed air.**
- ✓ Use vacuum or wet cleaning methods

Personal Protective Equipment

- ✓ Refer to task sheet 2.1.15 dedicated to Personal Protective Equipment.
- ✓ Dusts and sludges can damage the skin and eyes. Ask your safety clothing supplier to help you get the right PPE
- ✓ Risk assessment must be carried out to determine whether existing controls are adequate. If necessary, respiratory protective equipment (with the appropriate protection factor) should be provided and worn.
- ✓ Provide storage facilities to keep personal protective equipment clean when not in use.
- ✓ Replace respiratory protective equipment at intervals recommended by its suppliers.

Training

- ✓ Give your employees information on the health effects associated with respirable crystalline silica dust
- ✓ Provide employees with training on: dust exposure prevention; checking controls are working and using them; when and how to use any respiratory protective equipment provided and what to do if something goes wrong. Refer to task sheet 2.1.19 and part 1 of the Good Practice Guide.

Supervision

- ✓ Have a system to check that control measures are in place and that they are being followed. Refer to task sheet 2.1.17.
- ✓ Employers should make sure that employees have all the means to perform the checklist given opposite.

Employee checklist for making the best use of the controls

- ☐ **Ensure that you follow your employer's safe working procedure for emptying dust extraction units. Consider electrical isolation and manual handling issues.**
- ☐ **Ensure that you follow a working procedure when entering confined spaces.**
- ☐ **It may be necessary for you to wear respiratory protective equipment because this activity can be very dusty**
- ☐ **Empty the waste bin regularly and before it overflows.**
- ☐ **Empty the bin carefully and keep the tipping height as low as possible to avoid creating dust clouds. Be careful if handling dusts or sludges that may catch fire.**
- ☐ **Look for signs of damage, wear or poor operation of any equipment used. If you find any problems, tell your supervisor.**
- ☐ **If you think there is a problem with your dust control equipment, ensure additional control measures are taken to reduce exposure to respirable crystalline silica dust while the problem persists.**
- ☐ **Clear up spills immediately.**
- ☐ **Clean up using vacuum or wet cleaning methods.**
- ☐ **Use, maintain and store any respiratory protective equipment provided in accordance with instructions.**

Supervision

This sheet provides advice on the competence, training and information needs of managers/supervisors at sites where there is potential exposure to silica dust.

It needs to be applied in a way that is relevant to the particular management arrangements at the site, ie some sites could have a detailed management structure, whereas others could have a single manager.

This guidance sheet is aimed at employers to help them comply with the requirements of workplace health and safety legislation, by controlling exposure to respirable crystalline silica.

Specifically, this sheet provides good practice advice on the role of managers/supervisors in helping to minimize exposure to respirable crystalline silica. i.e. to apply appropriate protection and prevention measures.

This document should also be made available to persons who may be exposed to respirable crystalline silica in the workplace, in order that they understand the roles and responsibilities of managers/supervisors.

This sheet forms part of the Good Practices Guide on silica dust prevention, which is aimed specifically at the control of personal exposure to respirable crystalline silica dust in the workplace.

H&S Management Systems

- ✓ Employers should make sure that they are managing health and safety in line with a recognised H&S Management System (eg OHSAS 18001:1999, ILO OSH 2001). In the absence of a formal system, employers should be able to display the presence of a system in line with Directive 89/391/EEC (Framework Directive), which is subject to formal auditing.
- ✓ Managers/Supervisors should understand their role within a H&S management system

Needs of Managers/Supervisors

- ✓ Knowledge of health hazards of silica dust
- ✓ Understanding of processes likely to cause problems
- ✓ Understanding of control measures and their application
- ✓ Knowledge and understanding of the Good Practice Guide and the application of relevant task sheets

Training

- ✓ Employers need to ensure that their managers/supervisors are trained in order to meet the requirements placed upon them by the task sheets. In particular this is to enable them to
 - be an effective part of a system that checks that control measures are in place and that they are being followed
 - check that procedures for cleaning and maintenance are being followed
 - ensure that the health surveillance programme is being carried out for everyone that needs it
 - make sure that employees have all the means to perform the items included in the employee checklists for each relevant task sheet
- ✓ Training for managers/supervisors needs to include, specifically, knowledge and understanding of the "Good Practice Guide on Workers Health Protection through the Good Handling and Use of Crystalline Silica and Products containing it".
- ✓ Training should also include the development of communication skills for managers/supervisors
- ✓ Training must stress the importance of managers/supervisors setting a good example in following safe working procedures

Information

- ✓ Employers must provide sufficient information to managers/supervisors to meet the needs identified above.

Systems of packaging

This activity relates to the selection of the different packaging systems for silica products.

This guidance sheet is aimed at employers to help them comply with the requirements of workplace health and safety legislation, by controlling exposure to respirable crystalline silica.

Specifically, this sheet provides advice on the selection of the most appropriate delivery form for silica products.

Depending on the specific circumstances of each case, it may not be necessary to apply all of the control measures identified in this sheet in order to minimize exposure to respirable crystalline silica.

i.e. to apply appropriate protection and prevention measures.

This document should also be made available to persons who may be exposed to respirable crystalline silica in the workplace, in order that they may make the best use of the control measures which are implemented.

This sheet forms part of the Good Practices Guide on silica dust prevention, which is aimed specifically at the control of personal exposure to respirable crystalline silica dust in the workplace.

Access

- ✓ Restrict access to the work area to authorised personnel only.

Design and equipment

- ✓ Select only equipment that carries the CE mark.
- ✓ The choice of packaging will often be based on customer/user preference. Factors that will need to be considered when choosing supply options include:
 - ✓ Type of material (small particle size gives more potential for airborne dust generation);
 - ✓ Tonnages of material used;
 - ✓ Economics (payback from investment in bulk handling equipment compared to the premium that is charged for bags);
 - ✓ Degree of automation of the producer's and the end user's processes;
 - ✓ Permanence of supply (e.g. small bags may be more appropriate for trial products);
 - ✓ Health and safety requirements relating to ergonomics, manual handling, noise etc.
- ✓ The use of small bags gives the greatest potential for exposure to respirable crystalline silica during both bag filling and emptying
- ✓ The use of bulk (big) bags may help to reduce exposure for the producer. However, this can lead to increased problems at the customer premises due to difficulty in emptying the bags.
- ✓ Where possible, preference should be given to the use of enclosed bulk transport systems rather than using bags.



Maintenance

- ✓ Select machinery that has easy access for maintenance.
- ✓ Ensure equipment is maintained as advised by the supplier/installer in efficient working order and in good repair.

Examination and testing

- ✓ Visually check the storage area at least once per week for signs of damage or, if it is in constant use, check it more frequently. If used infrequently, then check it before each use.
- ✓ Keep records of inspections for a suitable period of time which complies with national laws (minimum five years).

Cleaning and housekeeping

- ✓ Select machinery that has easy access for cleaning.
- ✓ Clean work area daily.
- ✓ Deal with spills immediately.
- ✗ **Do not clean up with a dry brush or using compressed air.**
- ✓ Use vacuum or wet cleaning methods.

Personal Protective Equipment

- ✓ Refer to task sheet 2.1.15 dedicated to Personal Protective Equipment.
- ✓ Risk assessment must be carried out to determine whether existing controls are adequate. If necessary, respiratory protective equipment (with the appropriate protection factor) should be provided and worn.
- ✓ Provide storage facilities to keep personal protective equipment clean when not in use.
- ✓ Replace respiratory protective equipment at intervals recommended by its suppliers.

Training

- ✓ Give your employees information on the health effects associated with respirable crystalline silica dust
- ✓ Provide employees with training on: dust exposure prevention; checking controls are working and using them; when and how to use any respiratory protective equipment provided and what to do if something goes wrong. Refer to task sheet 2.1.19 and part 1 of the Good Practice Guide.

Supervision

- ✓ Have a system to check that control measures are in place and that they are being followed. Refer to task sheet 2.1.17.
- ✓ Employers should make sure that employees have all the means to perform the checklist given opposite.

Employee checklist for making the best use of the controls

- Use your work equipment in accordance with your employer's safe working procedures.
- Look for signs of damage, wear or poor operation of any equipment used. If you find any problems, tell your supervisor.
- If you think there is a problem with your dust control equipment, ensure additional control measures are taken to reduce exposure to respirable crystalline silica dust while the problem persists.
- When packages are damaged, take appropriate measures to protect yourself (personal protective equipment).
- Clear up spills straight away.
- Clean up using vacuum or wet cleaning methods.
- Use, maintain and store any respiratory protective equipment provided in accordance with instructions.

Training

This activity covers the organisation and implementation of training for workers who are exposed to respirable crystalline silica dust.

This guidance sheet is aimed at employers to help them comply with the requirements of workplace health and safety legislation, by controlling exposure to respirable crystalline silica.

Specifically, this sheet provides advice on organising and implementing training for workers who are exposed to crystalline silica dust. Following the key points of this task sheet will help reduce exposure. Depending on the specific circumstances of each case, it may not be necessary to apply all of the control measures identified in this sheet in order to minimize exposure to respirable crystalline silica. i.e. to apply appropriate protection and prevention measures.

This document should also be made available to persons who may be exposed to respirable crystalline silica in the workplace, in order that they may make the best use of the control measures which are implemented.

This sheet forms part of the Good Practices Guide on silica dust prevention, which is aimed specifically at the control of personal exposure to respirable crystalline silica dust in the workplace.



Access

- ✓ Ensure personnel receive training in silica dust awareness before allowing them access to dusty areas.

Organisation

- ✓ New employees should attend a training session on all aspects of health and safety, including the employer's safe working procedures for dealing with hazardous substances such as respirable crystalline silica. A comprehensive list of suggested training topics is given overleaf.
- ✓ Training sessions should be lively and informative, with a two-way dialogue between the trainer and the workers.
- ✓ Training should be provided by the employer and tailored to all those at risk and should draw examples from their workplace and work activities.
- ✓ Limit the number of participants so that everyone has an opportunity to discuss issues of concern and to ask questions.
- ✓ Limit the duration of training sessions and take regular breaks.
- ✓ Prohibit the use of mobile telephones and two-way radios during training sessions.
- ✓ Use a variety of training methods, incorporating visual aids, videos, group discussion and handouts.
- ✓ As an alternative to formal training sessions, toolbox talks are a useful means of communicating individual health and safety messages within a short period of time. Toolbox talks should be of maximum 15 minutes duration.
- ✓ Workers' knowledge should be assessed at the end of each training session in order to verify that they have understood the training material.
- ✓ Refresher training sessions should be organised to keep workers up to date on the health and safety aspects associated with work with products containing crystalline silica.
- ✓ Workers should be given access to this Good Practices Guide and its task sheets, along with any other additional information, including copies of risk assessments, safety data sheets and safe working procedures.

Training Topics

- ✓ Give your workers information on employer's and employee's duties under Health and Safety law.
- ✓ Give your workers information on the health effects associated with respirable crystalline silica dust.
- ✓ Provide them with training on factors affecting dust exposure and on dust exposure prevention.
- ✓ Provide them with training on good practices to use in the workplace and on safe working procedures.
- ✓ Provide them with training on protective measures and how to check that those controls are working.
- ✓ Provide them with training on when and how to use any respiratory protective equipment (RPE) or other personal protective equipment (PPE) provided.
- ✓ Provide them with training on how to maintain RPE/PPE, where to store it when not in use, how to obtain replacements and how to report defects.
- ✓ Provide them with training on what to do if something goes wrong.
- ✓ Give your workers information on dust monitoring programmes and the importance of their co-operation.
- ✓ Employees should also be informed of the conclusions of any personal exposure monitoring campaign.
- ✓ In the event that an employee's measured personal exposure to respirable crystalline silica exceeds the relevant occupational exposure limit value, that employee must be provided with details of his own personal exposure monitoring result.
- ✓ Employees should be informed about health surveillance procedures

Implementation

- ✓ Training sessions should be organised during employees' normal working time.
- ✓ Refresher training sessions should be conducted at least once every two years, or more often in the event of changes in working practices etc.
- ✓ Attendance at training sessions should be made compulsory. Attendance should be documented and records maintained as long as reasonably possible.
- ✓ Workers should be asked to provide feedback on each training session, which might help in the organisation of future training sessions.

Supervision

- ✓ Have a system to check that training sessions are planned, that they are well-attended, that their effectiveness is demonstrated by suitable methods and that the entire workforce is covered by them. Refer to task sheet 2.1.17.
- ✓ Employers should make sure that employees have all the means to perform the checklist given opposite.

Employee checklist for making the best use of the controls

- ☐ **Ensure that you attend all health and training sessions that are organised for you.**
- ☐ **Don't hesitate to ask questions during training sessions. You may be aware of problem areas, or solutions to problems, that have not previously been identified.**
- ☐ **Follow the Good Practices document and its task guidance sheets.**
- ☐ **Make sure you use the correct sheet for the task.**
- ☐ **Co-operate with your employer and other workers with specific responsibilities for the safety and health of workers, to enable your employer to ensure that your working environment and working conditions are as safe as possible.**
- ☐ **Immediately inform your employer, or other workers with specific responsibilities for the safety and health of workers, of any work situation that you think may represent a serious and immediate danger to safety and health.**
- ☐ **Make correct use of your work equipment and use all hazardous substances as directed.**
- ☐ **Use personal protective equipment, including respiratory protective equipment, as directed by your employer.**

Working with Contractors

This task sheet relates to the employment of external contractors in plants where airborne respirable crystalline silica dust may be generated.

This guidance sheet is aimed at employers to help them comply with the requirements of workplace health and safety legislation, requiring the same protection standards for external contractors as those applicable to their own employees.

Specifically, the advice given in this sheet is good practice for the management of all contract works, but the wording has been tailored to make it most relevant to circumstances where there is risk of exposure to respirable crystalline silica.

Depending on the specific circumstances of each case, it may not be necessary to apply all of the control measures identified in this sheet in order to minimize exposure to respirable crystalline silica. i.e. to apply appropriate protection and prevention measures.

This document should also be made available to contract firms and their employees who may be exposed to respirable crystalline silica in the workplace, in order that they may make the best use of the control measures which are implemented.

This sheet forms part of the Good Practices Guide on silica dust prevention, which is aimed specifically at the control of personal exposure to respirable crystalline silica dust in the workplace.

Existing national provisions must always be applied.

Access

- ✓ Restrict access to the work area to authorised personnel only.

Nature of contractors' work

It is typical for contractors to be employed in the following types of work (non exhaustive list):

- ✓ Design work
- ✓ Construction work
- ✓ Installation of plant and equipment
- ✓ Maintenance and servicing of equipment
- ✓ Equipment testing and calibration
- ✓ Specialist inspection services (eg asbestos, structural)
- ✓ Packaging (eg bagging)
- ✓ Mineral extraction and on-site haulage
- ✓ Road haulage
- ✓ Cleaning

Contractor selection criteria

When choosing contractors, the client's selection criteria must include an assessment of the contractor's health and safety performance.

Consider each of the following (non exhaustive list) and ensure that the contractor's performance against each of the criteria is adequate for the risks associated with the job and the area(s) in which it will be conducted.

- ✓ Health and safety policy document
- ✓ Certificates of training/competence
- ✓ Arrangements for health and safety advice and support
- ✓ Risk assessment and safe working procedures
- ✓ Availability of necessary work equipment
- ✓ Measures for control of hazardous substances
- ✓ Personal protective equipment arrangements
- ✓ Health surveillance arrangements
- ✓ Previous accident record
- ✓ Employer's Liability and Public Liability insurance arrangements

Do not allow a contractor to work on your site unless you are satisfied that he has given due consideration to all health and safety issues.

Exchange of communication

- ✓ It is the client's responsibility to inform external contractors of reasonably foreseeable risks (including those relating to respirable crystalline silica dust) that may be encountered on their site. This information must be provided in the form of written documentation at the pre-tender stage.
- ✓ Relevant sections of the Good Practices Guide and Fact Sheets should be sent to the Contractor as part of the pre-tender documentation.
- ✓ All contractors must be provided with induction training, prior to commencing work on the client's site, as a condition of them being authorised to enter the working area. If for some reason it is not practicable to provide induction training, then close personal supervision of the contractors must be provided by the client at all times.
- ✓ Induction training must include details of site rules and procedures, including any specific dust control measures that are relevant to the contract. Details should be provided of areas and activities for which personal protective equipment must be worn.
- ✓ During the induction session, contractors should be tested on their knowledge of their own safe working procedures. Do not allow work to commence until you are satisfied that all individual contractors are fully conversant with the requirements of their employer's safety documentation.
- ✓ It may be necessary under national regulations to appoint a central co-ordinator of specific contract works.

Written Agreement with Contractors

- ✓ Outsourcing agreements for jobs entailing potential exposure to respirable crystalline silica should contain a provision regarding health protection.
- ✓ The Good Practices Guide together with its Facts Sheets constitutes an integral part of the contract. This means that the Contractor will not only have to respect all general legal provisions regarding Health and Safety but also the recommendations of the Good Practices Document.

Supervision of contractors

The client must provide an appropriate level of supervision of all contractors who are working on their sites. The extent of this supervision will depend upon the complexity of the job and should, as a minimum, involve documented spot checks on the contractor's working practices. However, if it has not been practicable to provide full induction training, then contractors must be provided with close personal supervision at all times.

The client should have in place documented procedures for managing any situation in which a contractor fails to adhere to safe working procedures. Records should be maintained of all actions taken by both the client and the contract firm involved in addressing unsafe working practices.

Client's checklist for making the best use of the controls

- When selecting contractors, make an assessment of the adequacy of their systems for managing personal exposure to respirable crystalline silica dust.
- Ensure that contractors are provided with information on the health and safety risks present on your site that are relevant to their work.
- Provide contractors with induction training before allowing them to start work on your site.
- Ensure that you adequately supervise contractors in order to satisfy yourself that they are following safe working practices.
- Do not hesitate to stop the job if contractors are not working safely.

Contractor's checklist for making the best use of the controls

- Conduct risk assessments for all of your work activities and document them. You will be required to provide copies to your clients.
- Ensure that individual contractors are provided with training on the requirements of your risk assessments.
- Ensure that you maintain communication on health and safety issues with the client at all times.

2.2.1a

Bag emptying – small bags

This sheet provides advice on emptying of small bags of products containing crystalline silica in a production unit, particularly those containing dry materials.

This guidance sheet is aimed at employers to help them comply with the requirements of workplace health and safety legislation, by controlling exposure to respirable crystalline silica.

Specifically, this sheet provides good practice advice on dust control during small bag emptying operations. Following the key points of this task sheet will help reduce exposure.

Depending on the specific circumstances of each case, it may not be necessary to apply all of the control measures identified in this sheet in order to minimize exposure to respirable crystalline silica. i.e. to apply appropriate protection and prevention measures.

This document should also be made available to persons who may be exposed to respirable crystalline silica in the workplace, in order that they may make the best use of the control measures which are implemented.

This sheet forms part of the Good Practices Guide on silica dust prevention, which is aimed specifically at the control of personal exposure to respirable crystalline silica dust in the workplace.

Access

- ✓ Restrict access to the work area to authorised personnel only.

Design and equipment

- ✓ Ensure bag emptying equipment is fit for purpose.
- ✓ Enclose the bag emptying equipment as much as possible and keep it under negative pressure by using a local exhaust ventilation system – refer to task sheet 2.1.13.
- ✓ For small bags, the use of automatic or semi-automatic bag dumping stations is recommended for emptying the bags.
- ✓ Ensure workers tip the bag contents gently – never dump them. Bags should be emptied with the open end facing away.
- ✓ Bag crushing creates a lot of dust. Workers should roll up empty bags within the extraction zone.
- ✓ In order to dispose of empty bags without creating dust, drop them into a large plastic sack supported and held open by a metal frame. When it is full, seal the sack and dispose of it in a suitable waste skip. Do not let the waste sack overflow. Alternatively, use a compactor equipped with a dust extraction system or which is fully enclosed.
- ✓ Bag emptying equipment should be connected to a suitable dust arrestment system (e.g. bag filter/cyclone). A permanent dust extraction system is preferred, though a stand-alone mobile unit is acceptable.
- ✓ Bag emptying equipment should be designed for easy access to all parts for maintenance, unblocking and cleaning. Access panels should be interlocked or have trip devices where necessary to prevent persons accessing dangerous parts of machinery.
- ✓ Consider providing mechanical/pneumatic assistance with bag handling.
- ✓ Where possible keep bag emptying equipment away from doors, windows and walkways to prevent draughts affecting the performance of dust extraction systems.
- ✓ Provide a clean air supply to the workroom to replace extracted air.

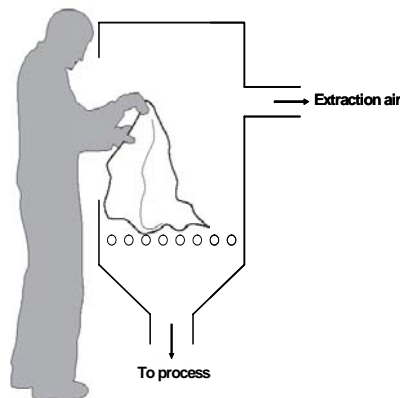

Manual Bag Emptying

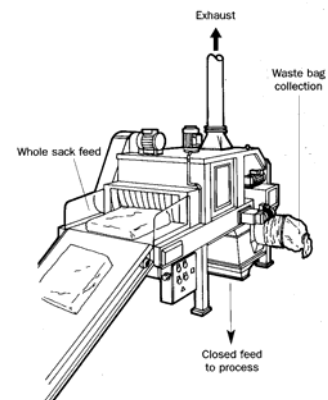

Automated Bag Emptying

Maintenance

- ✓ Ensure equipment used in the task is maintained as advised by the supplier/installer in efficient working order and in good repair.
- ✓ Replace consumables (filters etc) in accordance with the manufacturer's recommendations.

Examination and testing

- ✓ Visually check the cleaning equipment for signs of damage at least once per week or, if it is in constant use, check it more frequently. If used infrequently, then check it before each use.
- ✓ Obtain information on the design performance of dust suppression and/or extraction equipment from the supplier. Keep this information to compare with future test results.
- ✓ Keep records of inspections for a suitable period of time which complies with national laws (minimum five years).

Cleaning and housekeeping

- ✓ Clean your workplace on a regular basis.
- ✓ Deal with spills immediately.
- ✗ **Do not clean up with a dry brush or using compressed air.**
- ✓ Use vacuum or wet cleaning methods.

Personal Protective Equipment

- ✓ Refer to task sheet 2.1.15 dedicated to Personal Protective Equipment.
- ✓ Risk assessment must be carried out to determine whether existing controls are adequate. If necessary, respiratory protective equipment (with the appropriate protection factor) should be provided and worn.
- ✓ Provide storage facilities to keep personal protective equipment clean when not in use.
- ✓ Replace respiratory protective equipment at intervals recommended by its suppliers.

Training

- ✓ Give your employees information on the health effects associated with respirable crystalline silica dust
- ✓ Provide employees with training on: dust exposure prevention; checking controls are working and using them; when and how to use any respiratory protective equipment provided and what to do if something goes wrong. Refer to task sheet 2.1.19 and part 1 of the Good Practice Guide.

Supervision

- ✓ Have a system to check that control measures are in place and that they are being followed. Refer to task sheet 2.1.17.
- ✓ Employers should make sure that employees have all the means to perform the checklist given opposite.

Employee checklist for making the best use of the controls

- ☐ **Make sure the ventilation system is working properly. Make sure the dust extraction system is switched on and is working correctly before starting work.**
- ☐ **Look for signs of damage, wear or poor operation of any equipment used. If you find any problems, tell your supervisor.**
- ☐ **If you think there is a problem with your dust control equipment, ensure additional control measures are taken to reduce exposure to respirable crystalline silica dust while the problem persists.**
- ☐ **Use handling aids when available.**
- ☐ **Clear up spills straight away. Use vacuum or wet cleaning methods.**
- ☐ **Clean up work rooms using vacuum or wet cleaning techniques.**
- ☐ **Use, maintain and store any respiratory protective equipment provided in accordance with instructions.**

2.2.1b

Bag emptying – bulk bags

This sheet provides advice on how to empty bulk bags (big bags) of products containing crystalline silica in a production unit, particularly those containing dry materials.

This guidance sheet is aimed at employers to help them comply with the requirements of workplace health and safety legislation, by controlling exposure to respirable crystalline silica.

Specifically, this sheet provides good practice advice on dust control during bulk bag emptying operations. Following the key points of this task sheet will help reduce exposure.

Depending on the specific circumstances of each case, it may not be necessary to apply all of the control measures identified in this sheet in order to minimize exposure to respirable crystalline silica.

i.e. to apply appropriate protection and prevention measures.

This document should also be made available to persons who may be exposed to respirable crystalline silica in the workplace, in order that they may make the best use of the control measures which are implemented.

This sheet forms part of the Good Practices Guide on silica dust prevention, which is aimed specifically at the control of personal exposure to respirable crystalline silica dust in the workplace.

Access

- ✓ Restrict access to the work area to authorised personnel only.

Design and equipment

- ✓ Ensure bag emptying equipment is fit for purpose.
- ✓ Enclose the bag emptying equipment as much as possible and keep it under negative pressure by using a local exhaust ventilation system – refer to task sheet 2.1.13.
- ✗ **Manual bag cutting is not recommended without the use of personal protective equipment.**
- ✓ For single trip bulk bags without inner liner, use bag emptying equipment featuring pyramidal cutting knives and a rubber membrane to seal off the bag bottom.
- ✓ For multiple trip bulk bags, a discharge system with vibrator plate should be used and this should be equipped with local exhaust ventilation.
- ✓ Where multiple trip bulk bags are used, which have inner liners, special dust-free outlet connection systems are available which have double ring seals and fully enclosed product discharge.
- ✓ In order to dispose of empty bags without creating dust, do not manually compress the empty bags. Instead, drop them into a large plastic sack supported and held open by a metal frame. When it is full, seal the sack and dispose of it in a suitable waste skip. Do not let the waste sack overflow. Alternatively, use a compactor equipped with a dust extraction system or which is fully enclosed.
- ✓ Bag emptying equipment should be connected to a suitable dust arrestment system (e.g. bag filter/cyclone)
- ✓ Bag emptying equipment should be designed for easy access to all parts for maintenance, unblocking and cleaning. Access panels should be interlocked or have trip devices where necessary to prevent persons accessing dangerous parts of machinery.
- ✓ Consider providing mechanical/pneumatic assistance with bag handling.
- ✓ Where possible keep bag emptying equipment away from doors, windows and walkways to prevent draughts affecting the performance of dust extraction systems.
- ✓ Provide a clean air supply to the workroom to replace extracted air.



Maintenance

- ✓ Ensure equipment used in the task is maintained as advised by the supplier/installer in efficient working order and in good repair.
- ✓ Replace consumables (filters etc) in accordance with the manufacturer's recommendations.

Examination and testing

- ✓ Visually check the cleaning equipment for signs of damage at least once per week or, if it is in constant use, check it more frequently. If used infrequently, then check it before each use.
- ✓ Obtain information on the design performance of dust suppression and/or extraction equipment from the supplier. Keep this information to compare with future test results.
- ✓ Keep records of inspections for a suitable period of time which complies with national laws (minimum five years).

Cleaning and housekeeping

- ✓ Clean your workplace on a regular basis.
- ✓ Deal with spills immediately.
- ✗ **Do not clean up with a dry brush or using compressed air.**
- ✓ Use vacuum or wet cleaning methods.

Personal Protective Equipment

- ✓ Refer to task sheet 2.1.15 dedicated to Personal Protective Equipment.
- ✓ Risk assessment must be carried out to determine whether existing controls are adequate. If necessary, respiratory protective equipment (with the appropriate protection factor) should be provided and worn.
- ✓ Provide storage facilities to keep personal protective equipment clean when not in use.
- ✓ Replace respiratory protective equipment at intervals recommended by its suppliers.

Training

- ✓ Give your employees information on the health effects associated with respirable crystalline silica dust
- ✓ Provide employees with training on: dust exposure prevention; checking controls are working and using them; when and how to use any respiratory protective equipment provided and what to do if something goes wrong. Refer to task sheet 2.1.19 and part 1 of the Good Practice Guide.

Supervision

- ✓ Have a system to check that control measures are in place and that they are being followed. Refer to task sheets 2.1.17.
- ✓ Employers should make sure that employees have all the means to perform the checklist given opposite.

Employee checklist for making the best use of the controls

- ☐ **Make sure the ventilation system is working properly. Make sure the dust extraction system is switched on and is working correctly before starting work.**
- ☐ **Look for signs of damage, wear or poor operation of any equipment used. If you find any problems, tell your supervisor.**
- ☐ **If you think there is a problem with your dust control equipment, ensure additional control measures are taken to reduce exposure to respirable crystalline silica dust while the problem persists.**
- ☐ **Use handling aids when available.**
- ☐ **Clear up spills straight away. Use vacuum or wet cleaning methods.**
- ☐ **Clean up control rooms using vacuum or wet cleaning techniques.**
- ☐ **Use, maintain and store any respiratory protective equipment provided in accordance with instructions.**

2.2.2

Batch charging into the process - Glass

This activity relates to the charging of the humid batch by special charging machines from the furnace hopper into the melting furnace, which due to its operating conditions (high temperatures combined with positive pressure) generates a certain amount of dust.

This guidance sheet is aimed at employers to help them comply with the requirements of workplace health and safety legislation, by controlling exposure to respirable crystalline silica.

Specifically, this sheet provides advice on the charging of the humid batch by special charging machines from the furnace hopper into the melting furnace. Following the key points of this task sheet will help reduce exposure.

Depending on the specific circumstances of each case, it may not be necessary to apply all of the control measures identified in this sheet in order to minimize exposure to respirable crystalline silica. i.e. to apply appropriate protection and prevention measures.

This document should also be made available to persons who may be exposed to respirable crystalline silica in the workplace, in order that they may make the best use of the control measures which are implemented.

This sheet forms part of the Good Practices Guide on silica dust prevention, which is aimed specifically at the control of personal exposure to respirable crystalline silica dust in the workplace.

Access

- ✓ Restrict access to the work area to authorised personnel only.

Design and equipment

- ✓ Ensure that charging equipment is fit for purpose and well maintained.
- ✓ Adjust the sand seal system in accordance to supplier recommendations.
- ✓ Enclose the charging area as far as technically feasible.
- ✓ Assure the batch is charged at the appropriate humidity factor into the furnace.
- ✓ Furnace hoppers for the wet batch material should have an opening as small as practicable.
- ✓ Furnace hopper to be equipped with high level detection linked to alarming system to avoid overfilling.
- ✓ Ensure proper ventilation in the charging area.



Maintenance

- ✓ Ensure that the equipment is maintained as advised by the supplier in efficient working conditions.
- ✓ Check sand seal system on a daily base and adjust if necessary in accordance to supplier recommendations.

Examination and testing

- ✓ Visually check the equipment for signs of damage at least once per week or, if it is in constant use, check it more frequently. If used infrequently, then check it before each use.
- ✓ Keep records of inspections for a suitable period of time which complies with national laws (minimum five years).

Cleaning and housekeeping

- ✓ In order to prevent dust accumulation, clean the workplace on a regular base.
 - ✓ Deal immediately with spills. When dealing with bulk spillages of fine, dry, dusty materials, ensure that cleaning work is undertaken following a written safe working procedure and using the information in this sheet.
 - ✓ Use vacuum or wet cleaning methods.
- ✗ Do not clean up with a dry brush or using compressed air.

Personal Protective Equipment

- ✓ Refer to task sheet 2.1.15 dedicated to Personal Protective Equipment.
- ✓ If necessary, respiratory protective equipment should be provided and worn.
- ✓ Provide storage facilities to keep personal protective equipment clean when not in use.
- ✓ Replace respiratory protective equipment at intervals recommended by its suppliers.
- ✓ Risk assessment could be carried out to determine whether existing controls are appropriate.

Training

- ✓ Give your employees information on the health effects associated with respirable crystalline silica dust
- ✓ Provide employees with training on: dust exposure prevention; checking controls are working and using them; when and how to use any respiratory protective equipment provided and what to do if something goes wrong. Refer to task sheet 2.1.19 and part 1 of the Good Practice Guide.

Supervision

- ✓ Have a system to check that control measures are in place and that they are being followed. Refer to task sheet 2.1.17.
- ✓ Employers should make sure that employees have all the means to perform the checklist given opposite.

Employee checklist for making the best use of the controls

- ☐ Verify proper function of sand seal. If you notice any anomaly, inform your supervisor
- ☐ Immediately cleaning up bulk spillages of fine, dry dusty materials by using vacuum or wet cleaning methods. Ensure that you work in accordance with your Company's written safe working instruction.
- ☐ Use maintain and store any person protective equipment provided in accordance with instructions

2.2.3a

Bulk road tanker loading

This activity covers bulk loading operations for road tanker transport of products containing crystalline silica, particularly those containing dry materials.

This guidance sheet is aimed at employers to help them comply with the requirements of workplace health and safety legislation, by controlling exposure to respirable crystalline silica.

Specifically, this sheet provides good practice advice on dust control during bulk loading operations for road tanker transport. Following the key points of this task sheet will help reduce exposure.

Depending on the specific circumstances of each case, it may not be necessary to apply all of the control measures identified in this sheet in order to minimize exposure to respirable crystalline silica.

i.e. to apply appropriate protection and prevention measures.

This document should also be made available to persons who may be exposed to respirable crystalline silica in the workplace, in order that they may make the best use of the control measures which are implemented.

This sheet forms part of the Good Practices Guide on silica dust prevention, which is aimed specifically at the control of personal exposure to respirable crystalline silica dust in the workplace.

Access

- ✓ Restrict access to the work area to authorised personnel only.

Design and equipment

- ✓ Ensure the loading equipment is adequate and well maintained.
- ✓ Provide a loading bellow chute capable of extracting enough air to keep the loading point under negative pressure.
- ✓ The loading bellow should be connected to a suitable dust extraction system (e.g. a bag filter/cyclone).
- ✓ Make arrangements to discharge the air, which is displaced during loading of bulk products, so that it can not escape from the vessel.
- ✓ Provide where possible closed and depressurised transport equipment with adequate de-dusting equipment.
- ✓ Where possible, incline de-dusting ducts so as to avoid settling of dust. Ensure minimal internal wear on ducts by selecting wear resistant materials, using adequate duct dimensions and by avoiding sharp bends.
- ✓ Design ducts with appropriate internal diameter (increasing as one approaches the de-dusting system) in order to maintain adequate transport velocities and to prevent settling of dust.
- ✓ Try to avoid leakages as much as possible.
- ✓ Control cabins should have their own clean air supply, or may be fitted with forced air filtration.



Maintenance

- ✓ Ensure equipment used in the task is maintained as advised by the supplier/installer in efficient working order and in good repair.
- ✓ Replace consumables (filters etc) in accordance with the manufacturer's recommendations.

Examination and testing

- ✓ Visually check the cleaning equipment for signs of damage at least once per week or, if it is in constant use, check it more frequently. If used infrequently, then check it before each use.
- ✓ Obtain information on the design performance of the dust suppression and/or extraction equipment from the supplier. Keep this information to compare with future test results.
- ✓ Keep records of inspections for a suitable period of time which complies with national laws (minimum five years).

Cleaning and housekeeping

- ✓ Clean your workplace on a regular basis.
- ✗ **Do not clean up with a dry brush or using compressed air.**
- ✓ Use vacuum or wet cleaning methods

Personal Protective Equipment

- ✓ Refer to task sheet 2.1.15 dedicated to Personal Protective Equipment.
- ✓ Risk assessment must be carried out to determine whether existing controls are adequate. If necessary, respiratory protective equipment (with the appropriate protection factor) should be provided and worn.
- ✓ Provide storage facilities to keep personal protective equipment clean when not in use.
- ✓ Replace respiratory protective equipment at intervals recommended by its suppliers.

Training

- ✓ Give your employees information on the health effects associated with respirable crystalline silica dust
- ✓ Provide employees with training on: dust exposure prevention; checking controls are working and using them; when and how to use any respiratory protective equipment provided and what to do if something goes wrong. Refer to task sheet 2.1.19 and part 1 of the Good Practice Guide.

Supervision

- ✓ Have a system to check that control measures are in place and that they are being followed. Refer to task sheet 2.1.17.
- ✓ Employers should make sure that employees have all the means to perform the checklist given opposite.

Employee checklist for making the best use of the controls

- ☐ **Make sure the loading equipment is working properly. Make sure the dust extraction system is switched on and is working.**
- ☐ **Look for signs of damage, wear or poor operation of any equipment used. If you find any problems, tell your supervisor.**
- ☐ **If you think there is a problem with your dust control equipment, ensure additional control measures are taken to reduce exposure to respirable crystalline silica dust while the problem persists.**
- ☐ **Use handling aids when available.**
- ☐ **Clear up spills straight away. Use vacuum or wet cleaning methods.**
- ☐ **Clean up any control cabin using vacuum or wet cleaning methods.**
- ☐ **Use, maintain and store any respiratory protective equipment provided in accordance with instructions.**

2.2.3b

Bulk loading

This activity covers bulk loading operations for road (except road tankers), rail and water transport of crystalline silica containing materials particularly dry materials.

Sheet 2.2.2a offers advice on loading of road tankers.

This guidance sheet is aimed at employers to help them comply with the requirements of workplace health and safety legislation, by controlling exposure to respirable crystalline silica.

Specifically, this sheet provides good practice advice on dust control during bulk loading operations for road (except road tankers), railway and ship transport. Following the key points of this task sheet will help reduce exposure. Depending on the specific circumstances of each case, it may not be necessary to apply all of the control measures identified in this sheet in order to minimize exposure to respirable crystalline silica. i.e. to apply appropriate protection and prevention measures.

This document should also be made available to persons who may be exposed to respirable crystalline silica in the workplace, in order that they may make the best use of the control measures which are implemented.

This sheet forms part of the Good Practices Guide on silica dust prevention, which is aimed specifically at the control of personal exposure to respirable crystalline silica dust in the workplace.

Access

- ✓ Restrict access to the work area to authorised personnel only.

Design and equipment

- ✓ Ensure that all loading equipment is fit for purpose and well maintained.
- ✓ Appropriate techniques may include the use of conveyors, screw feeds, grabs, bucket elevators, hoppers, chutes and fill pipes.
- ✓ Enclose conveyors, chutes etc as much as possible.
- ✓ Minimise the speed of descent of the material:
 - ✓ Minimise falling distances – design chutes etc so that the material cascades. ie several short descents rather than one big one
 - ✓ Install baffles inside long fill pipes
 - ✓ Minimise slope angles in chutes, fill pipes etc
- ✗ Do not load flour products in the open air; enclosed systems must be used.
- ✓ Loading facilities should be sheltered to prevent dust being generated by the wind, whilst also providing a good standard of through-ventilation.
- ✓ Control cabins should be well-sealed and have their own clean air supply. Where necessary, they should be equipped with forced air filtration and maintained under positive pressure.
- ✓ CCTV systems can be used to reduce the need for operators to visit dusty areas.
- ✓ See task sheet 2.2.3a entitled “Bulk Road Tanker Loading” for advice on loading of road tankers.



Maintenance

- ✓ Ensure equipment used in the task is maintained as advised by the supplier/installer in efficient working order and in good repair.
- ✓ Replace consumables (filters etc) in accordance with the manufacturer's recommendations.

Examination and testing

- ✓ Visually check the cleaning equipment for signs of damage at least once per week or, if it is in constant use, check it more frequently. If used infrequently, then check it before each use.
- ✓ Obtain information on the design performance of ventilation equipment from the supplier. Keep this information to compare it with future test results.
- ✓ Keep records of inspections for a suitable period of time which complies with national laws (minimum five years).

Cleaning and housekeeping

- ✓ Clean your workplace on a regular basis.
- ✓ Deal with spills immediately.
- ✗ **Do not clean up with a dry brush or using compressed air.**
- ✓ Use vacuum or wet cleaning methods.

Personal Protective Equipment

- ✓ Refer to task sheet 2.1.15 dedicated to Personal Protective Equipment.
- ✓ Risk assessment must be carried out to determine whether existing controls are adequate. If necessary, respiratory protective equipment (with the appropriate protection factor) should be provided and worn.
- ✓ Indicate the need for respiratory protective equipment to be worn using appropriate pictogram signs.
- ✓ Provide storage facilities to keep personal protective equipment clean when not in use.
- ✓ Replace respiratory protective equipment at intervals recommended by its suppliers.

Training

- ✓ Give your employees information on the health effects associated with respirable crystalline silica dust
- ✓ Provide employees with training on: dust exposure prevention; checking controls are working and using them; when and how to use any respiratory protective equipment provided and what to do if something goes wrong. Refer to task sheet 2.1.19 and part 1 of the Good Practice Guide.
- ✓ Ensure that transport operators are provided with copies of loading procedures and training as necessary.

Supervision

- ✓ Have a system to check that control measures are in place and that they are being followed. Refer to task sheet 2.1.17.
- ✓ Employers should make sure that employees have all the means to perform the checklist given opposite.

Employee checklist for making the best use of the controls

- Make sure the loading equipment is working properly.**
- Make sure the ventilation system is switched on and is working.**
- Wear respiratory protective equipment (eg a dust mask) in areas where this has been deemed necessary.**
- Look for signs of damage, wear or poor operation of any equipment used. If you find any problems, tell your supervisor.**
- If you think there is a problem with your dust control equipment, ensure additional control measures are taken to reduce exposure to respirable crystalline silica dust while the problem persists.**
- Clear up spills straight away. Use vacuum or wet cleaning methods.**
- Use, maintain and store any respiratory protective equipment provided in accordance with instructions.**

Bulk road tanker unloading (blowing off)

This activity covers the discharge of silica sand and flour products from a road tanker into a storage silo, particularly dry materials.

This guidance sheet is aimed at employers to help them comply with the requirements of workplace health and safety legislation, by controlling exposure to respirable crystalline silica.

Specifically, this sheet provides advice on how to minimise the release of airborne dust when blowing off a road tanker of silica sand or flour. Following the key points of this task sheet will help reduce exposure.

Depending on the specific circumstances of each case, it may not be necessary to apply all of the control measures identified in this sheet in order to minimize exposure to respirable crystalline silica.

i.e. to apply appropriate protection and prevention measures.

This document should also be made available to persons who may be exposed to respirable crystalline silica in the workplace, in order that they may make the best use of the control measures which are implemented.

This sheet forms part of the Good Practices Guide on silica dust prevention, which is aimed specifically at the control of personal exposure to respirable crystalline silica dust in the workplace.

Access

- ✓ Restrict access to the work area to authorised personnel only.

Design and equipment

Road Tanker

- ✓ Limit the discharge rate to the design capacity of the receiving silo and dust extraction unit. Offloading pressures should be agreed with the silo operator.
- ✓ Tanker offloading pipes, connectors and seals must be designed to withstand the high air pressures and abrasion associated with blowing operations.
- ✓ Note that there will be a surge of air pressure as the last sand/flour is blown into a silo. Hence the need for constant supervision of offloading operations.

Customer silo

- ✓ Storage silos should be purchased only from reputable suppliers.
- ✓ Appropriate engineering design methods should be employed to ensure adequate structural strength.
- ✓ Engineering controls must be employed to prevent over-pressurisation of the silo while it is being filled. Ensure that the silos are equipped with pressure relief devices and high level alarms. They must also have dust extraction systems to remove and clean the displaced air.
- ✓ Silo dust extraction units must be fitted with filters that are appropriate to the particle size range of the product.
- ✓ Offloading pressures should be agreed with the tanker operator.
- ✓ Note that flour products have varying bulk density. Put in place procedures to ensure that silos are not overfilled.
- ✓ Silos should be equipped with a dust extraction system to prevent the emission of dust from the silo during tanker offloading.
- ✓ Pipework and ductwork should be designed to minimise shock losses (caused by bends, constrictions etc); to minimise dead spots where material may accumulate and to facilitate easy clearing of blockages.
- ✓ Silo connection points should be located as close as possible to the delivery tanker parking area. This will eliminate the need for long lengths of flexible hose.
- ✓ Safe means of access should be provided to those parts of the silo requiring inspection and maintenance.

Maintenance

- ✓ Maintain pipes/hoses, connectors and seals in good condition to reduce the likelihood of dust escaping during blowing operations.
- ✓ Dust extraction systems on silos must be maintained in accordance with manufacturers' instructions.

Examination and testing

- ✓ A competent person should test the performance of dust extraction systems at least annually.
- ✓ Tanker drivers should check the condition of pipes/hoses and seals daily and obtain replacements as necessary.
- ✓ Any faults with the pipes/hoses/connectors and silo dust extraction systems must be reported as soon as possible so that remedial action can be taken.

Cleaning and housekeeping

- ✓ The tanker offloading area should be kept clean and tidy
- ✓ Clean your workplace on a regular basis.
- ✓ Deal with spills immediately.
- ✗ **Do not clean up with a dry brush or using compressed air.**
- ✓ Use vacuum or wet cleaning methods.

Personal Protective Equipment

- ✓ Refer to task sheet 2.1.15 dedicated to Personal Protective Equipment.
- ✓ Risk assessment must be carried out to check the effectiveness of control measures.
- ✓ Respiratory protective equipment (with the appropriate protection factor) may need to be worn when disconnecting the offloading pipe at the back of the tanker, when remedying any escape of dust or in the event control measures fail.
- ✓ Provide storage facilities to keep personal protective equipment clean when not in use. Replace this equipment at intervals recommended by suppliers.

Training

- ✓ Give your employees information on the health effects associated with respirable crystalline silica dust
- ✓ Provide employees with training on: dust exposure prevention; checking controls are working and using them; when and how to use any respiratory protective equipment provided and what to do if something goes wrong. Refer to task sheet 2.1.19 and part 1 of the Good Practice Guide.

Supervision

- ✓ Ensure procedures are in place to prevent overfilling of silos.
- ✓ Have a system to check that dust control measures are in place and that they are being followed. Refer to task sheet 2.1.17.
- ✓ Employers should make sure that employees have all the means to perform the checklist given opposite.

Employee checklist for making the best use of the controls

- Tanker drivers must supervise their offloading operations at all times.
- Agree offloading pressures with the customer.
- Check the condition of pipes, hoses and connectors daily.
- Look for signs of damage, wear or poor operation of any equipment used. If you find any problems, tell your supervisor.
- If you think there is a problem with your dust control equipment, ensure additional control measures are taken to reduce exposure to respirable crystalline silica dust while the problem persists.
- Clean up spillages of sand and flour immediately, using wet cleaning methods.
- Wear a dust mask when it is necessary to enter dusty areas in order to rectify any escape of dust, or in the event other control measures fail.
- Use, maintain and store any respiratory protective equipment provided in accordance with instructions.

2.2.4b

Bulk unloading

This activity covers bulk unloading operations for road (except road tankers), rail and water transport of crystalline silica containing materials, particularly dry materials. Sheet 2.2.4a offers advice on unloading of road tankers.

This guidance sheet is aimed at employers to help them comply with the requirements of workplace health and safety legislation, by controlling exposure to respirable crystalline silica.

Specifically, this sheet provides good practice advice on dust control during bulk unloading operations. Following the key points of this task sheet will help reduce exposure.

Depending on the specific circumstances of each case, it may not be necessary to apply all of the control measures identified in this sheet in order to minimize exposure to respirable crystalline silica. i.e. to apply appropriate protection and prevention measures.

This document should also be made available to persons who may be exposed to respirable crystalline silica in the workplace, in order that they may make the best use of the control measures which are implemented.

This sheet forms part of the Good Practices Guide on silica dust prevention, which is aimed specifically at the control of personal exposure to respirable crystalline silica dust in the workplace.

Access

- ✓ Restrict access to the work area to authorised personnel only.

Design and equipment

- ✓ Ensure that all unloading equipment is fit for purpose and well maintained.
- ✓ When discharging dry products, install dust extraction systems in areas where dust may be emitted into the workplace air.
- ✓ Consider isolating the discharge area and keeping it under negative pressure. Alternatively, provide control rooms which are sealed and kept under positive pressure.
- ✓ Design the size and shape of receiving hoppers so that they are appropriate to the capacity of the road haulage vehicles, rail wagons, grabs etc feeding them.
- ✓ Prepare offloading procedures. Ensure that hoppers and discharge areas are clearly labelled with their contents.
- ✗ Do not discharge flour products in the open air; enclosed systems must be used.
- ✓ See task sheet 2.2.4a entitled "Bulk Road Tanker Unloading" for advice on blowing off dry products from road tankers.



Maintenance

- ✓ Ensure equipment used in the task is maintained as advised by the supplier/installer in efficient working order and in good repair.
- ✓ Replace consumables (filters etc) in accordance with the manufacturer's recommendations.

Examination and testing

- ✓ Visually check the cleaning equipment for signs of damage at least once per week or, if it is in constant use, check it more frequently. If used infrequently, then check it before each use.
- ✓ Obtain information on the design performance of dust extraction equipment from the supplier. Keep this information to compare it with future test results.
- ✓ Keep records of inspections for a suitable period of time which complies with national laws (minimum five years).

Cleaning and housekeeping

- ✓ Clean your workplace on a regular basis.
- ✓ Deal with spills immediately.
- ✗ **Do not clean up with a dry brush or using compressed air.**
- ✓ Use vacuum or wet cleaning methods.

Personal Protective Equipment

- ✓ Refer to task sheet 2.1.15 dedicated to Personal Protective Equipment.
- ✓ Risk assessment must be carried out to determine whether existing controls are adequate. If necessary, respiratory protective equipment (with the appropriate protection factor) should be provided and worn.
- ✓ Indicate the need for respiratory protective equipment to be worn using appropriate pictogram signs.
- ✓ Provide storage facilities to keep personal protective equipment clean when not in use.
- ✓ Replace respiratory protective equipment at intervals recommended by its suppliers.

Training

- ✓ Give your employees information on the health effects associated with respirable crystalline silica dust
- ✓ Provide employees with training on: dust exposure prevention; checking controls are working and using them; when and how to use any respiratory protective equipment provided and what to do if something goes wrong. Refer to task sheet 2.1.19 and part 1 of the Good Practice Guide.
- ✓ Ensure that delivery drivers are provided with copies of offloading procedures and training on these as necessary.

Supervision

- ✓ Have a system to check that control measures are in place and that they are being followed. Refer to task sheet 2.1.17.
- ✓ Employers should make sure that employees have all the means to perform the checklist given opposite.

Employee checklist for making the best use of the controls

- Make sure the unloading equipment is working properly.
- Make sure the dust extraction system is switched on and is working.
- Wear respiratory protective equipment (eg a dust mask) in areas where this has been deemed necessary.
- Look for signs of damage, wear or poor operation of any equipment used. If you find any problems, tell your supervisor.
- If you think there is a problem with your dust control equipment, ensure additional control measures are taken to reduce exposure to respirable crystalline silica dust while the problem persists.
- Clear up spills straight away. Use vacuum or wet cleaning methods.
- Use, maintain and store any respiratory protective equipment provided in accordance with instructions.

2.2.5

Core making and moulding in foundries

This activity covers core shop and moulding shop in foundries

This guidance sheet is aimed at employers to help them comply with the requirements of workplace health and safety legislation, by controlling exposure to respirable crystalline silica.

Specifically, this sheet provides advice on core making and moulding in foundries. Following the key points of this task sheet will help reduce exposure.

Depending on the specific circumstances of each case, it may not be necessary to apply all of the control measures identified in this sheet in order to minimize exposure to respirable crystalline silica. i.e. to apply appropriate protection and prevention measures.

This document should also be made available to persons who may be exposed to respirable crystalline silica in the workplace, in order that they may make the best use of the control measures which are implemented.

This sheet forms part of the Good Practices Guide on silica dust prevention, which is aimed specifically at the control of personal exposure to respirable crystalline silica dust in the workplace.

Access

- ✓ Restrict access to the work area to authorised personnel only.

Design and equipment

- ✓ Control sand spillage. Make sure the right amount of sand is used for the mould.
- ✓ You need an air speed typically between 0.5 and 1,5 metres per second into the enclosures. Refer to task sheet 2.1.13.
- ✓ Always confirm that the extraction is turned on and working at the start of work. Check the gauge.
- ✓ Discharge cleaned, extracted air to a safe place outside the building, away from doors, windows and air inlets.
- ✓ Have a supply of clean air coming into the workroom to replace extracted air.
- ✓ Consult a qualified ventilation engineer to design new control systems.

Maintenance

- ✓ Follow instructions in maintenance manuals.
- ✓ Keep equipment in effective and efficient working order.
- ✓ Repair faulty extraction systems immediately. Meanwhile, wear respiratory protective equipment (RPE).
- ✓ Sand is very abrasive and plant wears out quickly. Plan regular maintenance.

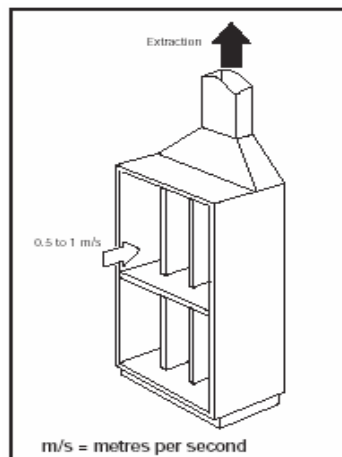
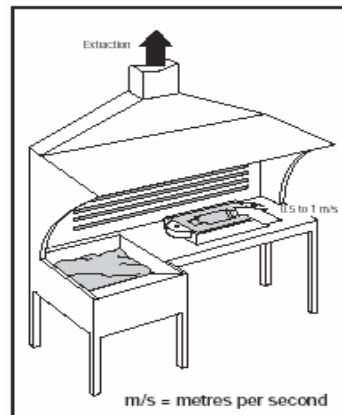

Examination and testing

- ✓ Look daily for signs of damage to the ducting, fan and air filter. Noisy or vibrating fans can indicate a problem. Repair damage immediately.
- ✓ At least once a week, check that the extraction system and gauge work properly.
- ✓ You need to know the manufacturer's performance specification to know if extraction is working properly.
- ✓ If this information isn't available, hire an engineer competent in ventilation techniques to determine its performance.
- ✓ The engineer's report must show the target air speeds.
- ✓ Keep this information in your testing logbook.
- ✓ Get an engineer competent in ventilation techniques to examine the system thoroughly and test its performance at least once every 12 months or obey national regulations.
- ✓ Keep records of inspections for a suitable period of time which complies with national laws (minimum five years).
- ✓ Review records to see if there are failure patterns that make planning maintenance easier.

Cleaning and housekeeping

- ✓ Every day, clear up accumulation of dirt in areas where people work all the time.
- ✓ Clean general workrooms once a week to stop dust being stirred up and to reduce slips.
- ✓ Use a vacuum cleaner fitted with a filter to clean up dust.
- X Do not clean up with a brush or with compressed air.**
- ✓ Shovel containers in a safe place.
- ✓ Keep lids on containers when they are not being filled or emptied.
- ✓ Dispose of empty containers safely.
- ✓ Dispose of wastes safely.

Personal Protective Equipment

- ✓ Refer to task sheet 2.1.15 dedicated to Personal Protective Equipment.
- ✓ Ask your safety-clothing supplier to help you get the right PPE.
- ✓ Respiratory protective equipment (RPE) should not be needed if the extraction is designed correctly and working properly.
- ✓ RPE is needed for maintenance and cleaning, and for clearing up spills.
- ✓ Use a P3 standard of RPE (Assigned Protection Factor 20) or equivalent standard. Consult your supplier for advice.
- ✓ Replace RPE filters as recommended by your supplier. Throw away disposable masks after one use.
- ✓ Provide storage facilities to keep personal protective equipment clean when not in use.
- ✓ Provide eye protection.
- X Never use compressed air use for removing dust from clothing.**
- X Workers must not take their coveralls home for washing. Use a contract laundry.**

Training

- ✓ Give your employees information on the health effects associated with respirable crystalline silica dust.
- ✓ Provide employees with training on: dust exposure prevention; checking controls are working and using them; when and how to use any respiratory protective equipment provided and what to do if something goes wrong. Refer to task sheet 2.1.19 and part 1 of the Good Practice Guide.

Supervision

- ✓ Have a system to check that control measures are in place and that they are being followed. Refer to task sheet 2.1.17.
- ✓ Employers should make sure that employees have all the means to perform the checklist given opposite.

Employee checklist for making the best use of the controls

- Make sure the room is well ventilated and any dust extraction system is switched on and is working.**
- Look for signs of damage, wear or poor operation of any equipment used, if you find any problems, tell your supervisor.**
- If you think there is a problem with your dust control equipment, ensure additional control measures are taken to reduce exposure to respirable crystalline silica dust while the problem persists.**
- Do not interface with ventilation systems – they are provided to protect your working environment.**
- Clean up using vacuum or wet cleaning methods.**
- Use, maintain and store any respiratory protective equipment provided in accordance with instructions.**

Crushing of minerals

Large quantities of airborne dust may be generated when minerals containing crystalline silica are fractured during crushing operations.

This guidance sheet is aimed at employers to help them comply with the requirements of workplace health and safety legislation, by controlling exposure to respirable crystalline silica.

Specifically, this sheet provides advice on the use of a crusher to break down boulders of quarried material into smaller lumps. Following the key points of this task sheet will help reduce exposure. Depending on the specific circumstances of each case, it may not be necessary to apply all of the control measures identified in this sheet in order to minimize exposure to respirable crystalline silica. i.e. to apply appropriate protection and prevention measures.

This document should also be made available to persons who may be exposed to respirable crystalline silica in the workplace, in order that they may make the best use of the control measures which are implemented.

This sheet forms part of the Good Practices Guide on silica dust prevention, which is aimed specifically at the control of personal exposure to respirable crystalline silica dust in the workplace.

Access

- ✓ Restrict access to the work area to authorised personnel only. This will help to protect people from the airborne dust hazard and from other hazards associated with crushing eg noise and ejected particles.

Design and equipment

- ✓ Little can be done to prevent the generation of airborne dust during crushing activities, so control of exposure relies upon isolation of plant operators from the dust that is generated.
- ✓ Machine controls should be located well away from sources of airborne dust generation.
- ✓ If it is necessary for someone to constantly supervise the operation of a crusher, then an enclosed, sealed cab should be provided.
- ✓ The use of CCTV systems will enable operators to check the operation of the crusher without being exposed to high dust levels.
- ✓ Operator's cabs (control rooms) should be physically separated from dusty areas and fed with clean fresh air, supplied under positive pressure. Alternatively, cabs should be fitted with air conditioning, equipped with an air filter that is designed to withstand a high loading of respirable dust particles.
- ✓ In order for the positive pressure supply or air conditioning system to provide the greatest protection from dust exposure, the doors and windows of the cab must be kept closed at all times while the crusher is in operation.
- ✓ Timing of crushing operations, to coincide with the wetter seasons of the year, will help to reduce airborne dust generation. Consideration should also be given to the use of water sprays to suppress dust.
- ✓ Location of a crusher outdoors will result in better ventilation, thus reducing airborne dust concentrations.
- ✓ If a crusher is located inside a building, then a good standard of through ventilation will be required to control dust levels.



Maintenance

- ✓ Maintain the cab air conditioning system as advised by the supplier, in effective and efficient working order.
- ✓ The air conditioning filter should be changed at the interval (in terms of hours of machine operation) advised by the manufacturer.

Examination and testing

- ✓ Crusher operators should check the condition of the air conditioning filter as recommended by manufacturers.
- ✓ Any faults with the air conditioning/filtration system must be reported as soon as possible so that remedial action can be taken.
- ✓ Keep records of inspections for a suitable period of time which complies with national laws (minimum five years).

Cleaning and housekeeping

- ✓ A build up of fine dust on the internal surfaces of the operator's cab might suggest a problem with the air conditioning system.
- ✓ Preference should be given to the use of vacuum or wet cleaning methods. Avoid using a dry brush when cleaning the internal surfaces of the operator's cab.

Personal Protective Equipment

- ✓ Refer to task sheet 2.1.15 dedicated to Personal Protective Equipment.
- ✓ Risk assessment must be carried out to check the effectiveness of control measures.
- ✓ Respiratory protective equipment (with the appropriate protection factor) may need to be worn if it is necessary to split large boulders manually, when carrying out routine plant checks or maintenance, or in the event other control measures fail.
- ✓ Provide storage facilities to keep personal protective equipment clean when not in use. Replace respiratory protective equipment at intervals recommended by its suppliers.

Training

- ✓ Give your employees information on the health effects associated with respirable crystalline silica dust
- ✓ Provide employees with training on: dust exposure prevention; checking controls are working and using them; when and how to use any respiratory protective equipment provided and what to do if something goes wrong. Refer to task sheet 2.1.19 and part 1 of the Good Practice Guide.

Supervision

- ✓ Have a system to check that dust control measures are in place and that they are being followed. Refer to task sheet 2.1.17.
- ✓ Employers should make sure that employees have all the means to perform the checklist given opposite.

Employee checklist for making the best use of the controls

- Keep the cab or control room doors and windows closed at all times when the crusher is in operation.
- Check the condition of the air conditioning filter once a week.
- Keep records of all safety checks on a daily check sheet.
- Look for signs of dust build up on the surfaces of the cab. This may be a sign that the air filter is in poor condition.
- If you think there is a problem with your dust control equipment, ensure additional control measures are taken to reduce exposure to respirable crystalline silica dust while the problem persists.
- Keep the interior of the cab clean.
- Wear a dust mask when it is necessary to enter dusty areas in order to manually split large boulders, during routine plant checks and during maintenance work.
- Use, maintain and store any respiratory protective equipment provided in accordance with instructions.

Cutting and Polishing Refractory Materials and Glass

This activity relates to the cutting of refractory materials and glass which may generate large quantities of airborne dust.

This guidance sheet is aimed at employers to help them comply with the requirements of workplace health and safety legislation, by controlling exposure to respirable crystalline silica.

Specifically, this sheet provides advice on the cutting and polishing of refractory materials and glass. Following the key points of this task sheet will help reduce exposure. Depending on the specific circumstances of each case, it may not be necessary to apply all of the control measures identified in this sheet in order to minimize exposure to respirable crystalline silica. i.e. to apply appropriate protection and prevention measures.

This document should also be made available to persons who may be exposed to respirable crystalline silica in the workplace, in order that they may make the best use of the control measures which are implemented.

This sheet forms part of the Good Practices Guide on silica dust prevention, which is aimed specifically at the control of personal exposure to respirable crystalline silica dust in the workplace.

Access

- ✓ Restrict access to the work area to authorised personnel only.

Design and equipment

- ✓ Dust control can be achieved by using wet cutting methods, which prevent fine dust from becoming airborne by trapping it in water.
- ✓ Ensure that water supplies are adequate and that they are maintained. Take precautions during cold weather against freezing.
- ✓ Take precautions to ensure the control of legionella and other biological agents. If the water used for wet cutting is re circulated, ensure that it is checked regularly with respect to pH value and contamination with micro organisms.
- ✓ The provision of appropriate drainage systems is essential when using water sprays and hoses.
- ✓ Ensure that electrical systems etc have adequate protection against the hazards present in the working environment, including water and silica dust.
- ✓ Use cutting and polishing tools containing no crystalline silica.



Maintenance

- ✓ Maintain the equipment as advised by the supplier, in efficient working order and good repair.

Examination and testing

- ✓ Visually check the equipment for signs of damage at least once per week or, if it is in constant use, check it more frequently. If used infrequently, then check it before each use.
- ✓ Keep records of inspections for a suitable period of time which complies with national laws (minimum five years).

Cleaning and housekeeping

- ✓ Clean the equipment regularly
- ✓ Use vacuum or wet cleaning methods
- ✗ **Do not clean up with a dry brush or using compressed air**
- ✗ **Do not allow deposits of dust/debris to dry out before cleaning up**

Personal Protective Equipment

- ✓ Refer to task sheet 2.1.15 dedicated to Personal Protective Equipment.
- ✓ Indicate areas where personal protective equipment must be worn
- ✓ Provide storage facilities to keep personal protective equipment clean when not in use.
- ✓ Replace respiratory protective equipment at intervals recommended by its suppliers
- ✓ Risk assessment could be carried out to determine whether existing controls are appropriate

Training

- ✓ Give your employees information on the health effects associated with respirable crystalline silica dust
- ✓ Provide employees with training on: dust exposure prevention; checking controls are working and using them; when and how to use any respiratory protective equipment provided and what to do if something goes wrong. Refer to task sheet 2.1.19 and part 1 of the Good Practice Guide.

Supervision

- ✓ Have a system to check that control measures are in place and that they are being followed. Refer to task sheet 2.1.17.
- ✓ Employers should make sure that employees have all the means to perform the checklist given opposite.

Employee checklist for making the best use of the controls

- Ensure that you follow your employer's safe working procedures.**
- Look for signs damage, wear or poor operation of any of the equipment used. If you find any problems, tell your supervisor.**
- Clean up the equipment after use**
- Clean using vacuum or wet cleaning method**
- Use maintain and store any respiratory protective equipment provided in accordance with instructions**

Drying minerals

This activity covers the operation for drying and cooling of products containing crystalline silica.

This guidance sheet is aimed at employers to help them comply with the requirements of workplace health and safety legislation, by controlling exposure to respirable crystalline silica.

Specifically, this sheet provides good practice advice on dust control for drying operations. Following the key points of this task sheet will help reduce exposure.

Depending on the specific circumstances of each case, it may not be necessary to apply all of the control measures identified in this sheet in order to minimize exposure to respirable crystalline silica. i.e. to apply appropriate protection and prevention measures.

This document should also be made available to persons who may be exposed to respirable crystalline silica in the workplace, in order that they may make the best use of the control measures which are implemented.

This sheet forms part of the Good Practices Guide on silica dust prevention, which is aimed specifically at the control of personal exposure to respirable crystalline silica dust in the workplace.

Access

- ✓ Restrict access to the work area to authorised personnel only.

Design and equipment

- ✓ Ensure that all drying/cooling equipment is fit for purpose and that it is well maintained.
- ✓ The plant should be enclosed as far as possible. Fluid bed dryers are generally more enclosed than rotary dryers.
- ✓ Outdoor installation of mineral dryers and coolers will help to reduce personal exposure to respirable crystalline silica dust, by taking advantage of natural ventilation. However, dryers and coolers that are installed outdoors will need to be designed for increased weather resistance.
- ✓ In situations where dryers and coolers are installed indoors, forced ventilation may be required in the building in order to ensure adequate dilution and removal of dusty air.
- ✓ Install a dust extraction system to serve all points from which dust may escape from the drying/cooling equipment and to maintain the system under negative pressure. This should be connected to a suitable dust extraction unit (e.g. a bag filter, cyclone or wet scrubber).
- ✓ Fine dust collected by the dust extraction unit can be returned to the dried product if additional precautions (e.g. closed circuit) are taken to protect those who may be exposed to this dust downstream, for example during bulk loading operations.
- ✓ Control cabins should have their own clean air supply. Where necessary, they should be equipped with forced air filtration and maintained under positive pressure. Dryer/cooler controls should be via telemetry in order to reduce the need for operators to visit dusty/noisy areas.
- ✓ Mineral dryers and coolers are subject to particulate emission limits and must be designed to satisfy local rules.



Maintenance

- ✓ Ensure the equipment used in the task is maintained as advised by the supplier/installer in efficient working order and in good repair.
- ✓ Replace consumables (filters etc) in accordance with the manufacturer's recommendations.

Examination and testing

- ✓ Visually check the equipment at least once per week for signs of damage or, if it is in constant use, check it more frequently. If used infrequently, then check it before each use.
- ✓ Obtain information on the design performance of the dust suppression and/or extraction equipment from the supplier. Keep this information to compare with future test results.
- ✓ Have the equipment examined and tested against its performance standard, at least once each year.
- ✓ Keep records of inspections for a suitable period of time which complies with national laws (minimum five years).

Cleaning and housekeeping

- ✓ Clean your workplace on a regular basis.
- ✗ **Do not clean up with a dry brush or using compressed air.**
- ✓ Use vacuum or wet cleaning methods.

Personal Protective Equipment

- ✓ Refer to task sheet 2.1.15 dedicated to Personal Protective Equipment.
- ✓ Risk assessment must be carried out to determine whether existing controls are adequate. If necessary, respiratory protective equipment (with the appropriate protection factor) should be provided and worn.
- ✓ Provide storage facilities to keep personal protective equipment clean when not in use.
- ✓ Replace respiratory protective equipment at intervals recommended by its suppliers.

Training

- ✓ Give your employees information on the health effects associated with respirable crystalline silica dust
- ✓ Provide employees with training on: dust exposure prevention; checking controls are working and using them; when and how to use any respiratory protective equipment provided and what to do if something goes wrong. Refer to task sheet 2.1.19 and part 1 of the Good Practice Guide.

Supervision

- ✓ Have a system to check that control measures are in place and that they are being followed. Refer to task sheet 2.1.17.
- ✓ Employers should make sure that employees have all the means to perform the checklist given opposite.

Employee checklist for making the best use of the controls

- ☐ **Make sure that the dust extraction system is switched on and that it is working correctly.**
- ☐ **Look for signs of damage, wear or poor operation of any equipment used. If you find any problems, tell your supervisor.**
- ☐ **If you think there is a problem with your dust control equipment, ensure additional control measures are taken to reduce exposure to respirable crystalline silica dust while the problem persists.**
- ☐ **Clear up spills straight away. Use vacuum or wet cleaning methods.**
- ☐ **Clean up control rooms using vacuum or wet cleaning methods.**
- ☐ **Test if control rooms are under pressure, keep doors and windows shut.**
- ☐ **Use, maintain and store any respiratory protective equipment provided in accordance with instructions.**

2.2.9

Dry pressing - ceramics

This activity relates to pressing of materials (powders or granulates) containing crystalline silica as a shaping process

This guidance sheet is aimed at employers to help them comply with the requirements of workplace health and safety legislation, by controlling exposure to respirable crystalline silica.

Specifically, this sheet provides good practice advice on dust control during pressing materials containing crystalline silica as a shaping process. Following the key points of this task sheet will help reduce exposure. Depending on the specific circumstances of each case, it may not be necessary to apply all of the control measures identified in this sheet in order to minimize exposure to respirable crystalline silica. i.e. to apply appropriate protection and prevention measures.

This document should also be made available to persons who may be exposed to respirable crystalline silica in the workplace, in order that they may make the best use of the control measures which are implemented.

This sheet forms part of the Good Practices Document on silica dust prevention, which is aimed specifically at the control of personal exposure to respirable crystalline silica dust in the workplace.

Access

- ✓ Restrict access to the working area to authorised personnel only.

Design and equipment

- ✓ Enclose the materials transfer system and the pressing system as much as possible.
- ✓ Provide local exhaust ventilation around the pressing system with an inward airflow of at least 1 m/s at the point where the dust is generated. Refer to task sheet 2.1.13.
- ✓ Consider the need for additional ventilation at the discharge of the pressed parts and transfer points. Ensure air discharges from pneumatic systems do not interfere with the dust control measures.
- ✓ Design any enclosure in sections to allow easy access for cleaning and maintenance.
- ✓ Prevent material from falling down by using an appropriate device.
- ✓ Where possible, locate the work area away from doors, windows and walkways to stop draughts interfering with the ventilation and spreading dust.
- ✓ Provide an air supply to the workroom to replace extracted air.
- ✓ Keep ducts short and simple.
- × Avoid long sections of flexible duct.
- ✓ Provide an easy way of checking the control is working, e.g. a manometer, pressure gauge or tell-tale (a small flag).
- ✓ Discharge extracted air to a safe place away from doors, windows and air inlets.
- ✓ You can re-circulate cleaned and filtered air into the workroom in quantities recommended by existing standards.

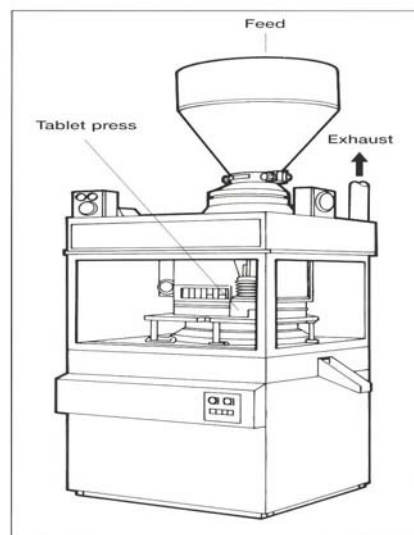

Maintenance

- ✓ Ensure equipment used in the task is maintained as advised by the supplier/installer in efficient working order and in good repair.
- ✓ Replace consumables (filters etc.) in accordance with the manufacturer's recommendations.

Examination and testing

- ✓ Obtain information on the design performance of the ventilation equipment from the supplier. Keep this information to compare with future test results.
- ✓ Visually check all equipment at least once per week for signs of damage or, if it is in constant use, check it more frequently. If used infrequently, then check it before each use.
- ✓ Have the ventilation equipment examined and tested against its performance standard, at least once each year.
- ✓ Keep records of inspections for a suitable period of time which complies with national laws (minimum five years).

Cleaning and housekeeping

- ✓ Clean your workplace and equipment on a regular basis.
- ✓ Deal with spills immediately.
- ✓ Store containers in a safe place and dispose of empty containers safely.
- ✓ Use vacuum or wet cleaning methods.
- X Do not clean up with a dry brush or using compressed air.**

Personal Protective Equipment

- ✓ Refer to task sheet 2.1.15 dedicated to Personal Protective Equipment.
- ✓ Risk assessment must be carried out to determine whether existing controls are adequate. If necessary, respiratory protective equipment (with the appropriate protection factor) should be provided and worn.
- ✓ Provide storage facilities to keep personal protective equipment clean, when not in use.
- ✓ Replace personal protective equipment at intervals recommended by the manufacturer/supplier.

Training

- ✓ Give your employees information on the health effects associated with respirable crystalline silica dust.
- ✓ Provide employees with training on: dust exposure prevention; checking controls are working and using them; when and how to use any respiratory protective equipment provided and what to do if something goes wrong. Refer to task sheet 2.1.19 and part 1 of the Good Practice Guide.

Supervision

- ✓ Have a system to check that control measures are in place and that they are being followed. Refer to task sheet 2.1.17.
- ✓ Employers should make sure that employees have all the means to perform the checklist given opposite.

Employee checklist for making the best use of the controls

- Make sure the ventilation system is switched on and is working.
- Make sure it is running properly; check the manometer, pressure gauge or tell-tale.
- Look for signs of damage, wear or poor operation of any equipment used. If you find any problems, tell your supervisor.
- If you think there is a problem with your dust control equipment, ensure additional control measures are taken to reduce exposure to respirable crystalline silica dust while the problem persists.
- Make sure that paper bags and other waste material aren't drawn into the ventilation duct.
- Clear up spills immediately. Use vacuum cleaning or wet cleaning methods. Dispose of spills safely.
- Do not clean up with a dry brush or using compressed air.
- Put lids on containers immediately after use.
- Use, maintain and store any respiratory protective equipment provided in accordance with instructions.

2.2.10

Fettling larger castings in foundries

This activity covers fettling shop, when fettling larger castings.

This guidance sheet is aimed at employers to help them comply with the requirements of workplace health and safety legislation, by controlling exposure to respirable crystalline silica.

Specifically, this sheet provides advice on fettling sheet of larger castings. Following the key points of this task sheet will help reduce exposure.

Depending on the specific circumstances of each case, it may not be necessary to apply all of the control measures identified in this sheet in order to minimize exposure to respirable crystalline silica. i.e. to apply appropriate protection and prevention measures.

This document should also be made available to persons who may be exposed to respirable crystalline silica in the workplace, in order that they may make the best use of the control measures which are implemented.

This sheet forms part of the Good Practices Guide on silica dust prevention, which is aimed specifically at the control of personal exposure to respirable crystalline silica dust in the workplace.

Access

- ✓ Restrict access to the work area to authorised personnel only.

Design and equipment

- ✓ Respiratory protective equipment (RPE) is needed.
- ✓ Provide a ventilated booth for fettling larger castings.
- ✓ RPE is needed for larger castings.
- ✓ You need an air speed typically between 1 and 1,5 metre per second into the booth, and typically between 2.5 and 10 metres per second at the extraction point. Refer to task sheet 2.1.13.
- ✓ Always confirm that the extraction is turned on and working at the start of work. Check the gauge.
- ✓ Discharge cleaned, extracted air to a safe place outside the building, away from doors, windows and air inlets.
- ✓ Ensure that enough fresh air (20%) is supplied where employees are working in order to dilute and remove the airborne dust produced.
- ✓ Position the workpiece so that it is as close as possible to the extraction point.
- ✓ Ensure that fettling dust is directed into the booth.
- ✓ Provide a turntable to move the casting.
- X **Workers should not stand between the casting and the extraction point.**
- ✓ Consult a qualified ventilation engineer to design new control systems

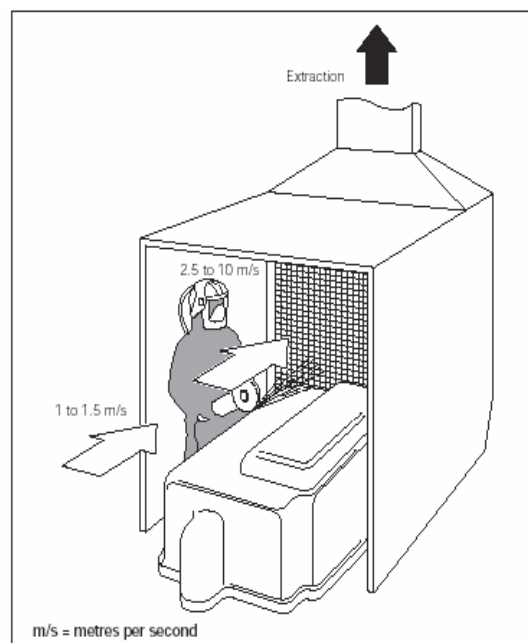

Maintenance

- ✓ Follow instructions in maintenance manuals.
- ✓ Keep equipment in effective and efficient working order.
- ✓ Repair faulty extraction systems immediately. Meanwhile, wear respiratory protective equipment (RPE).
- ✓ Fettlings are very abrasive and plant wears out quickly. Fettlings can block extraction points. Plan regular maintenance.

Examination and testing

- ✓ Look daily for signs of damage to the ducting, fan and air filter. Noisy or vibrating fans can indicate a problem. Repair damage immediately.
- ✓ At least once a week, check that the extraction system and gauge work properly.
- ✓ You need to know the manufacturer's performance specification to know if extraction is working properly.
- ✓ If this information isn't available, hire an engineer competent in ventilation techniques to determine its performance.
- ✓ The engineer's report must show the target air speeds.
- ✓ Keep records of inspections for a suitable period of time which complies with national laws (minimum five years).

Cleaning and housekeeping

- ✓ Every day, clear up accumulations of dirt in areas where people work all the time.
- ✓ Clean general workrooms once a week to stop dust being stirred up and to reduce slips.
- ✓ Use a vacuum cleaner fitted with a filter to clear up fine dust.
- X Don't clean up with a brush or with compressed air.**
- ✓ Shovel large spills carefully to avoid stirring up dust.

Personal Protective Equipment

- ✓ Refer to task sheet 2.1.15 dedicated to Personal Protective Equipment.
- ✓ Ask your safety-clothing supplier to help you get the right PPE.
- ✓ Respiratory protective equipment (RPE) is needed for work inside a booth, for maintenance and cleaning, and for clearing up chemical spills.
- ✓ Use air-fed or powered RPE with an Assigned Protection Factor of at least 40.
- ✓ Consult your supplier for advice.
- ✓ Provide storage facilities to keep personal protective equipment clean when not in use.
- ✓ Provide eye protection.
- ✓ Protective gloves are needed to help prevent injuries.
- X Never allow compressed air use for removing dust from clothing.**
- X Workers must not take their coveralls home for washing. Use a contract laundry**

Training

- ✓ Give your employees information on the health effects associated with respirable crystalline silica dust.
- ✓ Provide employees with training on: dust exposure prevention; checking controls are working and using them; when and how to use any respiratory protective equipment provided and what to do if something goes wrong. Refer to task sheet 2.1.19 and part 1 of the Good Practice Guide.

Supervision

- ✓ Have a system to check that control measures are in place and that they are being followed. Refer to task sheet 2.1.17.
- ✓ Employers should make sure that employees have all the means to perform the check list given opposite.

Employee checklist for making the best use of the controls

- ☐ **Make sure the room is well ventilated and any dust extraction system is switched on and is working.**
- ☐ **Look for signs of damage, wear or poor operation of any equipment used, if you find any problems, tell your supervisor.**
- ☐ **If you think there is a problem with your dust control equipment, ensure additional control measures are taken to reduce exposure to respirable crystalline silica dust while the problem persists.**
- ☐ **Do not interface with ventilation systems – they are provided to protect your working environment.**
- ☐ **Clean up using vacuum or wet cleaning methods.**
- ☐ **Use, maintain and store any respiratory protective equipment provided in accordance with instructions.**

2.2.11

This guidance sheet is aimed at employers to help them comply with the requirements of workplace health and safety legislation, by controlling exposure to respirable crystalline silica.

Specifically, this sheet provides advice on fettling of smaller castings. Following the key points of this task sheet will help reduce exposure.

Depending on the specific circumstances of each case, it may not be necessary to apply all of the control measures identified in this sheet in order to minimize exposure to respirable crystalline silica.

i.e. to apply appropriate protection and prevention measures.

This document should also be made available to persons who may be exposed to respirable crystalline silica in the workplace, in order that they may make the best use of the control measures which are implemented.

This sheet forms part of the Good Practices Guide on silica dust prevention, which is aimed specifically at the control of personal exposure to respirable crystalline silica dust in the workplace.

Fettling smaller castings in foundries

This activity covers the fettling of smaller castings.

Access

- ✓ Restrict access to the work area to authorised personnel only.

Design and equipment

- ✓ Control fettlings and dust. Fettle small castings in a ventilated booth.
- ✓ Fettle very small castings using an abrasive or wire wheel fitted with local exhaust ventilation (LEV).
- ✓ You need an air speed typically between 1 and 2.5 metres per second into the fettling booth, or typically between 2.5 and 10 metres per second into pedestal grinder openings. Refer to task sheet 2.1.13.
- ✓ Always confirm that the extraction is turned on and working at the start of work. Check the gauge.
- ✓ Discharge cleaned, extracted air to a safe place outside the building, away from doors, windows and air inlets.
- ✓ Have a supply of clean air coming into the workroom to replace extracted air.
- ✓ Position the work piece so that it is as close as possible to the extraction point.
- ✓ Ensure that fettling dust is directed into the booth and that pneumatic tools do not blow dust out of the booth.
- ✓ Provide a turntable to move the casting.
- ✓ Consult a qualified ventilation engineer to design new control systems.

Maintenance

- ✓ Follow instructions in maintenance manuals.
- ✓ Keep equipment in effective and efficient working order.
- ✓ Repair faulty extraction systems immediately. Meanwhile, wear respiratory protective equipment (RPE).
- ✓ Fettlings are very abrasive and plant wears out quickly. Fettlings can block extraction points. Plan regular maintenance.

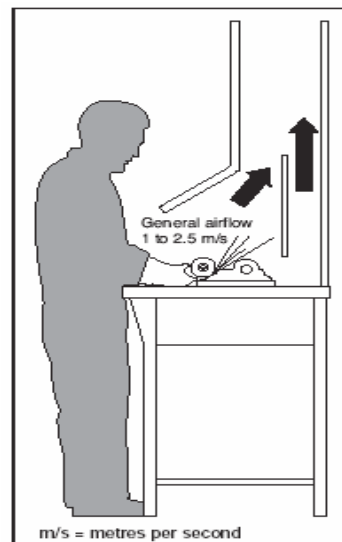

Examination and testing

- ✓ Look daily for signs of damage to the ducting, fan and air filter. Noisy or vibrating fans can indicate a problem. Repair damage immediately.
- ✓ At least once a week, check that the extraction system and gauge work properly.
- ✓ You need to know the manufacturer's performance specification to know if extraction is working properly.
- ✓ If this information isn't available, hire an engineer competent in ventilation techniques to determine its performance.
- ✓ The engineer's report must show the target air speeds.
- ✓ Keep this information in your testing logbook.
- ✓ Get an engineer competent in ventilation techniques to examine the system thoroughly and test its performance at least once every 12 months or obey national regulations.
- ✓ Keep records of inspections for a suitable period of time which complies with national laws (minimum five years).
- ✓ Review records to see if there are failure patterns that make planning maintenance easier.

Cleaning and housekeeping

- ✓ Every day, clear up accumulations of dirt in those areas where people work all the time.
- ✓ Clean general workrooms once a week to stop dust being stirred up and to reduce slips.
- ✓ Use a vacuum cleaner fitted with a filter to clear up fine dust.
- X Don't clean up with a brush or with compressed air**

Personal protective equipment (PPE)

- ✓ Refer to task sheet 2.1.15 dedicated to Personal Protective Equipment.
- ✓ Ask your safety-clothing supplier to help you get the right PPE.
- ✓ Respiratory protective equipment (RPE) is not normally needed when working at a ventilated work bench. RPE is needed for other fettling, for maintenance and cleaning, and for clearing up spills.
- ✓ Use a P3 standard of RPE (Assigned Protection Factor 20) or equivalent standard. Consult your supplier for advice.
- ✓ Replace RPE filters as recommended by your supplier. Throw away disposable masks after one use.
- ✓ Provide storage facilities to keep personal protective equipment clean when not in use.
- ✓ Provide eye protection.
- ✓ Protective gloves are needed to help prevent injuries.
- X Never allow compressed air use for removing dust from clothing.**
- X Workers must not take their coveralls home for washing. Use a contract laundry.**

Training

- ✓ Give your employees information on the health effects associated with respirable crystalline silica dust
- ✓ Provide employees with training on: dust exposure prevention; checking controls are working and using them; when and how to use any respiratory protective equipment provided and what to do if something goes wrong. Refer to task sheet 2.1.19 and part 1 of the Good Practice Guide.

Supervision

- ✓ Have a system to check that control measures are in place and that they are being followed. Refer to task sheet 2.1.17.
- ✓ Employers should make sure that employees have all the means to perform the check list given opposite.

Employee checklist for making the best use of the controls

- Make sure the room is well ventilated and any dust extraction system is switched on and is working.**

- Look for signs of damage, wear or poor operation of any equipment used, if you find any problems, tell your supervisor.**

- If you think there is a problem with your dust control equipment, ensure additional control measures are taken to reduce exposure to respirable crystalline silica dust while the problem persists.**

- Do not interface with ventilation systems – they are provided to protect your working environment.**

- Clean up using vacuum or wet cleaning methods.**

- Use, maintain and store any respiratory protective equipment provided in accordance with instructions.**

Final Treatment (dry) - Ceramics

This activity relates to dry machining operations (e.g. grinding, sawing, drilling) of ceramic products containing crystalline silica.

This guidance sheet is aimed at employers to help them comply with the requirements of workplace health and safety legislation, by controlling exposure to respirable crystalline silica.

Specifically, this sheet provides good practice advice on dust control during dry machining operations on ceramic products containing crystalline silica. Following the key points of this task sheet will help reduce exposure. Depending on the specific circumstances of each case, it may not be necessary to apply all of the control measures identified in this sheet in order to minimize exposure to respirable crystalline silica. i.e. to apply appropriate protection and prevention measures.

This document should also be made available to persons who may be exposed to respirable crystalline silica in the workplace, in order that they may make the best use of the control measures which are implemented.

This sheet forms part of the Good Practices Document on silica dust prevention, which is aimed specifically at the control of personal exposure to respirable crystalline silica dust in the workplace.

Access

- ✓ Restrict access to the working area to authorised personnel only.
- ✓ The work area and equipment should be clearly labelled.
- ✓ Traffic ways should be marked

Design and equipment

- ✓ Enclose the machining station as much as possible.
- ✓ Provide local exhaust ventilation around the machining station with an inward airflow of typically at least 1 m/s at the point where the dust is generated. Refer to task sheet 2.1.13.
- ✓ Consider the need for additional ventilation at the discharge of the machined parts and transfer points.
- ✓ Ensure air discharges from pneumatic systems do not interfere with the dust control measures.
- ✓ Design any enclosure in sections to allow easy access for cleaning and maintenance.
- ✓ Where possible, locate the work area away from doors, windows and walkways to stop draughts interfering with the ventilation and spreading dust.
- ✓ Provide an air supply to the workroom to replace extracted air.
- ✓ Keep ducts short and simple.
- ✗ Avoid long sections of flexible duct.
- ✓ Provide an easy way of checking the control is working, e.g. a manometer, pressure gauge or tell-tale (a small flag).
- ✓ Discharge extracted air to a safe place away from doors, windows and air inlets.
- ✓ You can re-circulate clean filtered air into the workroom. Quantities of recirculated air should be in compliance with existing standards.



Maintenance

- ✓ Ensure equipment used in the task is maintained as advised by the supplier/installer in efficient working order and in good repair.
- ✓ Replace consumables (filters etc.) in accordance with the manufacturer's recommendations.

Examination and testing

- ✓ Obtain information on the design performance of the ventilation equipment from the supplier. Keep this information to compare with future test results.
- ✓ Visually check all equipment at least once per week for signs of damage or, if it is in constant use, check it more frequently. If used infrequently, then check it before each use.
- ✓ Have the ventilation equipment examined and tested against its performance standard, at least once each year.
- ✓ Keep records of inspections for a suitable period of time which complies with national laws (minimum five years).

Cleaning and housekeeping

- ✓ Clean your workplace and equipment on a regular basis.
- ✓ Deal with spills immediately.
- ✓ Use vacuum or wet cleaning methods.
- X Do not clean up with a dry brush or using compressed air.**

Personal Protective Equipment

- ✓ Refer to task sheet 2.1.15 dedicated to Personal Protective Equipment.
- ✓ Risk assessment must be carried out to determine whether existing controls are adequate. If necessary, respiratory protective equipment (with the appropriate protection factor) should be provided and worn.
- ✓ Provide storage facilities to keep personal protective equipment clean, when not in use.
- ✓ Replace personal protective equipment at intervals recommended by the manufacturer/supplier.

Training

- ✓ Give your employees information on the health effects associated with respirable crystalline silica dust.
- ✓ Provide employees with training on: dust exposure prevention; checking controls are working and using them; when and how to use any respiratory protective equipment provided and what to do if something goes wrong. Refer to task sheet 2.1.19 and part 1 of the Good Practice Guide.

Supervision

- ✓ Have a system to check that control measures are in place and that they are being followed. Refer to task sheet 2.1.17.
- ✓ Employers should make sure that employees have all the means to perform the checklist given opposite.

Employee checklist for making the best use of the controls

- Make sure the ventilation system is switched on and is working.
- Make sure it is running properly; check the manometer, pressure gauge or tell-tale.
- Look for signs of damage, wear or poor operation of any equipment used. If you find any problems, tell your supervisor.
- If you think there is a problem with your dust control equipment, ensure additional control measures are taken to reduce exposure to respirable crystalline silica dust while the problem persists.
- Clear up spills immediately. Use vacuum cleaning or wet cleaning methods for solids. Dispose of spills safely.
- Do not clean up with a dry brush or using compressed air.
- Use, maintain and store any respiratory protective equipment provided in accordance with instructions.

2.2.13

Firing (biscuit, glaze, final, decoration) - Ceramics

This activity relates to the firing of ceramic products in periodic or continuous kilns. The measures for biscuit firing, glaze firing, final firing or decoration firing are similar.

This guidance sheet is aimed at employers to help them comply with the requirements of workplace health and safety legislation, by controlling exposure to respirable crystalline silica.

Specifically, this sheet provides good practice advice on dust control during firing of ceramic products containing crystalline silica. The firing process can be periodic or continuous. Following the key points of this task sheet will help reduce exposure. Depending on the specific circumstances of each case, it may not be necessary to apply all of the control measures identified in this sheet in order to minimize exposure to respirable crystalline silica. i.e. to apply appropriate protection and prevention measures.

This document should also be made available to persons who may be exposed to respirable crystalline silica in the workplace, in order that they may make the best use of the control measures which are implemented.

This sheet forms part of the Good Practices Document on silica dust prevention, which is aimed specifically at the control of personal exposure to respirable crystalline silica dust in the workplace.

Access

- ✓ Restrict access to the working area to authorised personnel only.

Design and equipment

- ✓ Good thermal insulation should be applied.
- ✓ Local exhaust ventilation should be applied to the entry and exit points of a continuous kiln or to the door of a periodic kiln (to prevent vapour loss, contamination and dust emissions).
- ✓ Exhaust ventilation systems should be easily controllable, interlocked to the kiln heating controls and fitted with warning lights/alarms.
- ✗ **When feeding the kiln, avoid any friction of the products to be fired (design of transportation units).**
- ✓ Where possible, locate the work area away from doors, windows and walkways to stop draughts interfering with the ventilation and spreading dust.
- ✓ Provide an air supply to the workroom to replace extracted air.
- ✓ Provide an easy way of checking the control is working, e.g. a manometer, pressure gauge or tell-tale (a small flag).
- ✓ Discharge extracted air to a safe place away from doors, windows and air inlets.
- ✗ **Air re-circulation is not recommended.**



Maintenance

- ✓ Ensure equipment used in the task is maintained as advised by the supplier/installer in efficient working order and in good repair.
- ✓ Replace consumables (filters etc.) in accordance with the manufacturer's recommendations.

Examination and testing

- ✓ Obtain information on the design performance of the ventilation equipment from the supplier. Keep this information to compare with future test results.
- ✓ Visually check all equipment at least once per week for signs of damage or, if it is in constant use, check it more frequently. If used infrequently, then check it before each use.
- ✓ Have the ventilation equipment examined and tested against its performance standard, at least once each year.
- ✓ Keep records of inspections for a suitable period of time which complies with national laws (minimum five years).

Cleaning and housekeeping

- ✓ Clean your workplace and equipment on a regular basis.
- ✓ Deal with spills immediately.
- ✓ Use vacuum or wet cleaning methods.
- X Do not clean up with a dry brush or using compressed air.**

Personal Protective Equipment

- ✓ Refer to task sheet 2.1.15 dedicated to Personal Protective Equipment.
- ✓ Risk assessment must be carried out to determine whether existing controls are adequate. If necessary, respiratory protective equipment (with the appropriate protection factor) should be provided and worn.
- ✓ Provide storage facilities to keep personal protective equipment clean, when not in use.
- ✓ Replace personal protective equipment at intervals recommended by the manufacturer/supplier.

Training

- ✓ Give your employees information on the health effects associated with respirable crystalline silica dust.
- ✓ Provide employees with training on: dust exposure prevention; checking controls are working and using them; when and how to use any respiratory protective equipment provided and what to do if something goes wrong. Refer to task sheet 2.1.19 and part 1 of the Good Practice Guide.

Supervision

- ✓ Have a system to check that control measures are in place and that they are being followed. Refer to task sheet 2.1.17.
- ✓ Employers should make sure that employees have all the means to perform the checklist given opposite.

Employee checklist for making the best use of the controls

- Make sure the ventilation system is switched on and is working.
- Make sure it is running properly; check the manometer, pressure gauge or tell-tale.
- Look for signs of damage, wear or poor operation of any equipment used. If you find any problems, tell your supervisor.
- If you think there is a problem with your dust control equipment, ensure additional control measures are taken to reduce exposure to respirable crystalline silica dust while the problem persists.
- Remove broken products immediately from feeding units.
- Clear up spills immediately. Use vacuum cleaning or wet cleaning methods. Dispose of spills safely.
- Do not clean up with a dry brush or using compressed air.
- Use, maintain and store any respiratory protective equipment provided in accordance with instructions.

Glass Furnace Batch Charging (Container Glass)

This activity relates to the charging of glass making raw materials, which contain crystalline silica, to the glass melting furnace.

This guidance sheet is to be read in conjunction with the sheet entitled Cleaning (2.1.1).

This guidance sheet is aimed at employers to help them comply with the requirements of workplace health and safety legislation, by controlling exposure to respirable crystalline silica.

Specifically, this sheet provides advice on dust control during the charging of glass making raw materials to the furnace. Following the key points of this task sheet will help reduce exposure.

Depending on the specific circumstances of each case, it may not be necessary to apply all of the control measures identified in this sheet in order to minimize exposure to respirable crystalline silica. i.e. to apply appropriate protection and prevention measures.

This document should also be made available to persons who may be exposed to respirable crystalline silica in the workplace, in order that they may make the best use of the control measures which are implemented.

This sheet forms part of the Good Practices Guide on silica dust prevention, which is aimed specifically at the control of personal exposure to respirable crystalline silica dust in the workplace.

Access

- ✓ Restrict access to the work area to authorised personnel only.

Design and equipment

- ✓ The extent to which the batch charging equipment can be sealed against the egress of airborne dust is limited by its operational characteristics and the need to work in harsh temperature conditions. Other design and operational features can reduce the release of dust.
- ✓ Stream feed of materials in to the batch charger from the furnace batch hopper will:
 - a) Prevent the blow back of dust in to the atmosphere as a result of the furnace atmosphere being held at a positive pressure.
 - b) Prevent dust being created by materials falling from a height in to the charger.
- ✓ If delivery equipment linking the furnace batch hopper to the batch charger is used instead of flood feed, then the charger hopper should be fitted with level detection/control to prevent it emptying and allowing blow back of dust in to the atmosphere.
- ✓ If delivery equipment linking the furnace batch hopper to the batch charger is used instead of flood feed, then it should be sealed against the release of dust where possible.
- ✓ In the glass industry the use of moist batch (typically 1-3% moisture content) is the normal practice, which aids dust suppression.
- ✓ If dry batch is used then it is recommended that some form of dust extraction or dust suppression should be fitted.
- ✓ Furnace hopper to be equipped with level detection to avoid over filling.

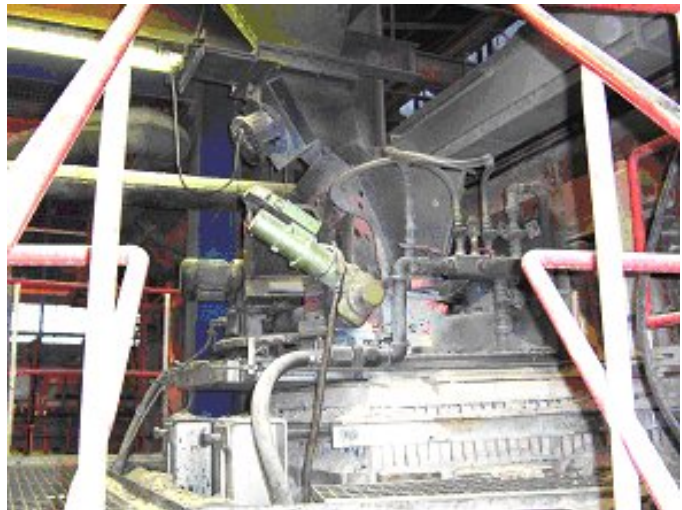

Maintenance

- ✓ Maintain any dust seals fitted to equipment
- ✓ Maintain charging system to prevent any batch spillages
- ✓ Maintain any level detection equipment that is fitted.
- ✓ If a dust extraction system is fitted it must be maintained in accordance with the manufacturers' instructions.

Examination and testing

- ✓ A competent person should test the performance of dust extraction systems at least annually.
- ✓ The batch charging system should be inspected for faults or signs of wear that could cause batch spillages once per week or if it is in constant use, more frequently. If used infrequently, then check it before each use.
- ✓ Keep records of inspections for a suitable period of time which complies with national laws (minimum five years).

Cleaning and housekeeping

- ✓ Clean the batch charger and the surrounding area on a regular basis.
- X Do not clean using compressed air.**
- ✓ If practicable, use a vacuum or wet cleaning measures.
- ✓ Develop written safe working procedures for dealing with large spillages of dusty materials.

Personal Protective Equipment

- ✓ Refer to task sheet 2.1.15 dedicated to Personal Protective Equipment.
- ✓ Appropriate respiratory protective equipment must be provided when carrying out cleaning and if necessary maintenance procedures.
- ✓ Provide storage facilities to keep personal protective equipment clean when not in use and replace as required by manufacturers' instructions.
- ✓ Risk assessment must be carried out to determine whether existing controls are adequate.

Training

- ✓ Give your employees information on the health effects associated with respirable crystalline silica dust
- ✓ Provide employees with training on: dust exposure prevention; checking controls are working and using them; when and how to use any respiratory protective equipment provided and what to do if something goes wrong. Refer to task sheet 2.1.19 and part 1 of the Good Practice Guide.

Supervision

- ✓ Have a system to check that control measures are in place and that they are being followed. Refer to task sheet 2.1.17.
- ✓ Employers should make sure that employees have all the means to perform the checklist given opposite.

Employee checklist for making the best use of the controls

- Make sure the equipment is working properly**
- Look for signs of wear that can lead to batch spillage**
- If fitted make sure all dust extraction systems are working correctly**
- Dust clouds may suggest a problem with the system. Investigate them immediately**
- If you think there is a problem with the plant or with your dust control equipment, ensure additional control measures are taken to reduce exposure to respirable crystalline silica dust while the problem persists**
- Clear up spills straight away. Use vacuum or wet cleaning methods. Dispose of spills safely**
- Use, maintain and store any respiratory protective equipment provided in accordance with instructions**

Glass Sandblasting

This activity relates to the glass sandblasting. The dust generated may contain respirable crystalline silica coming from the sand. This safety sheet is available for a sandblasting line with an enclosed sandblasting equipment. This equipment is fully automatic in normal running (no manual operation during the production).

This guidance sheet is aimed at employers to help them comply with the requirements of workplace health and safety legislation, by controlling exposure to respirable crystalline silica.

Specifically, this sheet provides advice on glass sandblasting. Following the key points of this task sheet will help reduce exposure. Depending on the specific circumstances of each case, it may not be necessary to apply all of the control measures identified in this sheet in order to minimize exposure to respirable crystalline silica. i.e. to apply appropriate protection and prevention measures.

This document should also be made available to persons who may be exposed to respirable crystalline silica in the workplace, in order that they may make the best use of the control measures which are implemented.

This sheet forms part of the Good Practices Guide on silica dust prevention, which is aimed specifically at the control of personal exposure to respirable crystalline silica dust in the workplace.

Access

- ✓ Restrict access to the work area to authorised personnel only.

Design and equipment

- ✓ Ensure the equipment is fit for purpose and that it is well maintained.
- ✓ Equipment should be enclosed as far as technically feasible.
- ✓ The equipment should be connected to a suitable dust extraction system.
- ✓ Ensure all equipment is easily accessible for maintenance work.
- ✓ Ensure that equipments are designed in such a way that there is no individual contact with crystalline silica.

Maintenance

- ✓ Maintain the equipment as advised by the suppliers, in efficient working order and good repair.
- ✓ Check sand seal system on a daily base and adjust if necessary in accordance to supplier recommendations.

Examination and testing

- ✓ Visually check the equipment before use.
- ✓ Keep records of inspections for a suitable period of time which complies with national laws (minimum five years).

Cleaning and housekeeping

- ✓ Clean the equipment regularly
- ✓ Deal immediately with leakages
- ✓ Deal immediately with spills. When dealing with bulk spillages of fine, dry, dusty materials, ensure that cleaning work is undertaken following a written safe working procedure and using the information in this sheet.
- ✓ Use vacuum or wet cleaning methods
- ✗ Do not clean up with a dry brush or using compressed air

Personal Protective Equipment

- ✓ Refer to task sheet 2.1.15 dedicated to Personal Protective Equipment.
- ✓ Indicate areas where personal protective equipment must be worn
- ✓ Provide storage facilities to keep personal protective equipment clean when not in use.
- ✓ Replace respiratory protective equipment at intervals recommended by its suppliers
- ✓ Risk assessment could be carried out to determine whether existing controls are appropriate.

Training

- ✓ Give your employees information on the health effects associated with respirable crystalline silica dust
- ✓ Provide employees with training on: dust exposure prevention; checking controls are working and using them; when and how to use any respiratory protective equipment provided and what to do if something goes wrong. Refer to task sheet 2.1.19 and part 1 of the Good Practice Guide.

Supervision

- ✓ Have a system to check that control measures are in place and that they are followed. Refer to task sheet 2.1.17.
- ✓ Employers should make sure that employees have all the means to perform the checklist given opposite.

Employee checklist for making the best use of the controls

- Make sure that the glass sandblasting equipment is working properly.
- Ensure that you follow your employer's safe working procedures.
- Look for signs damage, wear or poor operation of any of the equipment used. If you find any problems, tell your supervisor.
- Clean up the equipment regularly
- Clean using vacuum or wet cleaning method
- Use maintain and store any respiratory protective equipment provided in accordance with instructions
- Change work clothes when required

Grinding of minerals

This sheet gives guidance on dry grinding operations for products containing crystalline silica.

This guidance sheet is aimed at employers to help them comply with the requirements of workplace health and safety legislation, by controlling exposure to respirable crystalline silica.

Specifically, this sheet provides good practice advice on dust control for grinding operations. Following the key points of this task sheet will help reduce exposure.

Depending on the specific circumstances of each case, it may not be necessary to apply all of the control measures identified in this sheet in order to minimize exposure to respirable crystalline silica.

i.e. to apply appropriate protection and prevention measures.

This document should also be made available to persons who may be exposed to respirable crystalline silica in the workplace, in order that they may make the best use of the control measures which are implemented.

This sheet forms part of the Good Practices Guide on silica dust prevention, which is aimed specifically at the control of personal exposure to respirable crystalline silica dust in the workplace.

Access

- ✓ Restrict access to the work area to authorised personnel only.

Design and equipment

- ✓ Ensure the grinding installation is fit for purpose and that it is well maintained.
- ✓ Use wet milling processes wherever possible, rather than dry grinding operations. This will greatly reduce airborne dust generation.
- ✓ Enclose grinding installations as much as possible and install them in well-ventilated buildings.
- ✓ Where necessary to prevent the escape of dust, grinding installations should be connected to a suitable dust extraction system, which is capable of extracting enough air to keep the relevant parts of the installation under negative pressure.
- ✓ Make arrangements for the dust-free discharge of the product from the grinding mill to other process equipment. Transfer points and subsequent plant should also be connected to a dust extraction system where necessary to prevent the escape of dust.
- ✓ Note that some parts of the system will operate at pressures above atmospheric. Provide good seals between different parts of the installation.
- ✓ Ensure all equipment is easily accessible for maintenance work.
- ✓ Provide ducts with sufficient inclination to avoid settling of product.
- ✓ Ensure minimal internal wear of ducts by using ones of adequate diameter; by selecting wear resistant materials and by avoiding sharp bends. Alumina is a good material to use to line ducts that are subject to high wear.
- ✓ Control rooms should have their own clean air supply and they should be physically separated from dusty areas. Where necessary they should be fitted with forced air filtration and maintained under positive pressure to prevent the ingress of dusty air.
- ✓ Put in place control systems to avoid overloading the grinding mills.
- ✓ Where possible, provide automated sampling, particle size analysis, telemetry and CCTV systems to reduce the amount of time operators need to spend in dusty/noisy areas.



Maintenance

- ✓ Ensure equipment used in the task is maintained as advised by the supplier/installer in efficient working order and in good repair.
- ✓ Replace consumables (filters etc) in accordance with the manufacturer's recommendations.

Examination and testing

- ✓ Visually check the equipment at least once per week for signs of damage or, if it is in constant use, check it more frequently. If used infrequently, then check it before each use.
- ✓ Obtain information on the design performance of dust suppression and/or extraction equipment from the supplier. Keep this information to compare with future test results.
- ✓ Have the extraction equipment examined and tested against its performance standard at least once each year.
- ✓ Keep records of inspections for a suitable period of time which complies with national laws (minimum five years).

Cleaning and housekeeping

- ✓ Clean your workplace on a regular basis.
- ✗ **Do not clean up with a dry brush or using compressed air.**
- ✓ Use vacuum or wet cleaning methods.
- ✓ Develop written safe working procedures for dealing with large spillages of dusty material.

Personal Protective Equipment

- ✓ Refer to task sheet 2.1.15 dedicated to Personal Protective Equipment.
- ✓ Risk assessment must be carried out to determine whether existing controls are adequate. If necessary, respiratory protective equipment (with the appropriate protection factor) should be provided and worn.
- ✓ Provide storage facilities to keep personal protective equipment clean when not in use.
- ✓ Replace respiratory protective equipment at intervals recommended by its suppliers.

Training

- ✓ Give your employees information on the health effects associated with respirable crystalline silica dust
- ✓ Provide employees with training on: dust exposure prevention; checking controls are working and using them; when and how to use any respiratory protective equipment provided and what to do if something goes wrong. Refer to task sheet 2.1.19 and part 1 of the Good Practice Guide.

Supervision

- ✓ Have a system to check that control measures are in place and that they are being followed. Refer to task sheet 2.1.17.
- ✓ Employers should make sure that employees have all the means to perform the checklist given opposite.

Employee checklist for making the best use of the controls

- Make sure the grinding installation is working properly.**
- Make sure all dust extraction systems are switched on and working correctly before starting work.**
- Look for signs of damage, wear or poor operation of any equipment used. If you find any problems, tell your supervisor.**
- Dust clouds may suggest a problem with the system. Investigate them immediately.**
- If you think there is a problem with the plant or with your dust control equipment, ensure additional control measures are taken to reduce exposure to respirable crystalline silica while the problem persists.**
- Clear up spills straight away. Use vacuum or wet cleaning methods. Dispose of spills safely.**
- Clean up control rooms using vacuum or wet cleaning techniques.**
- Use, maintain and store any respiratory protective equipment provided in accordance with instructions.**

Grinding of Glass

This activity relates to the grinding of glass with sand prior to polishing. The dust generated may contain respirable crystalline silica coming from the sand.

This guidance sheet is aimed at employers to help them comply with the requirements of workplace health and safety legislation, by controlling exposure to respirable crystalline silica.

Specifically, this sheet provides advice on the grinding of glass with sand prior to polishing. Following the key points of this task sheet will help reduce exposure.

Depending on the specific circumstances of each case, it may not be necessary to apply all of the control measures identified in this sheet in order to minimize exposure to respirable crystalline silica. i.e. to apply appropriate protection and prevention measures.

This document should also be made available to persons who may be exposed to respirable crystalline silica in the workplace, in order that they may make the best use of the control measures which are implemented.

This sheet forms part of the Good Practices Guide on silica dust prevention, which is aimed specifically at the control of personal exposure to respirable crystalline silica dust in the workplace.

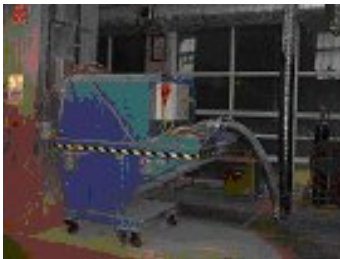

Access

- ✓ Restrict access to the work area to authorised personnel only.

Design and equipment

- ✓ Dust control can be achieved by using wet grinding methods, which prevent fine dust from becoming airborne by trapping it in water.
- ✓ Ensure that water supplies are adequate and that they are maintained. Take precautions during cold weather against freezing.
- ✓ Take precautions to ensure the control of legionella and other biological agents. If the water used for wet grinding is recirculated, ensure that it is checked regularly with respect to PH value and contamination with micro organisms.
- ✓ The provision of appropriate drainage systems is essential when using water sprays and hoses.
- ✓ Ensure that electrical systems etc have adequate protection against the hazards present in the working environment, including water and silica dust.
- ✓ Enclose grinding installations as much as possible and install them in a well ventilated building
- ✓ Ensure all equipment is easily accessible for maintenance work
- ✓ Provide your workers with an adequate supply of clean working clothes, including spare sets. overalls should be made of a finely woven fabric to prevent dust being absorbed. Workers should not take their dirty work clothes home; these should be cleaned by the employer as required.



Maintenance

- ✓ Maintain the equipment as advised by the supplier, in efficient working order and good repair.
- ✓ Check sand seal system on a daily base and adjust if necessary in accordance to supplier recommendations.

Examination and testing

- ✓ Visually check the equipment before use.
- ✓ Keep records of inspections for a suitable period of time which complies with national laws (minimum five years).

Cleaning and housekeeping

- ✓ Clean the equipment regularly
- ✓ Deal immediately with spills. When dealing with bulk spillages of fine, dry, dusty materials, ensure that cleaning work is undertaken following a written safe working procedure and using the information in this sheet.
- ✓ Use vacuum or wet cleaning methods
- ✗ Do not clean up with a dry brush or using compressed air
- ✗ Do not allow deposits of dust/debris to dry out before cleaning up

Personal Protective Equipment

- ✓ Refer to task sheet 2.1.15 dedicated to Personal Protective Equipment.
- ✓ Indicate areas where personal protective equipment must be worn
- ✓ Provide storage facilities to keep personal protective equipment clean when not in use.
- ✓ Replace respiratory protective equipment at intervals recommended by its suppliers
- ✓ Risk assessment could be carried out to determine whether existing controls are appropriate.

Training

- ✓ Give your employees information on the health effects associated with respirable crystalline silica dust
- ✓ Provide employees with training on: dust exposure prevention; checking controls are working and using them; when and how to use any respiratory protective equipment provided and what to do if something goes wrong. Refer to task sheet 2.1.19 and part 1 of the Good Practice Guide.

Supervision

- ✓ Have a system to check that control measures are in place and that they are followed. Refer to task sheet 2.1.17.
- ✓ Employers should make sure that employees have all the means to perform the checklist given opposite.

Employee checklist for making the best use of the controls

- Ensure that you follow your employer's safe working procedures.
- Look for signs of damage, wear or poor operation of any of the equipment used. If you find any problems, tell your supervisor.
- Clean up the equipment after use
- Clean using vacuum or wet cleaning method
- Use maintain and store any respiratory protective equipment provided in accordance with instructions
- Change work clothes when required

Isostatic Pressing (dry) - Ceramics

This activity relates to the isostatic pressing of ceramic products containing crystalline silica. Dust is possible while filling the moulds and when removing them.

This guidance sheet is aimed at employers to help them comply with the requirements of workplace health and safety legislation, by controlling exposure to respirable crystalline silica.

Specifically, this sheet provides good practice advice on dust control during isostatic pressing of ceramic products containing crystalline silica. Following the key points of this task sheet will help reduce exposure. Depending on the specific circumstances of each case, it may not be necessary to apply all of the control measures identified in this sheet in order to minimize exposure to respirable crystalline silica, i.e. to apply appropriate protection and prevention measures.

This document should also be made available to persons who may be exposed to respirable crystalline silica in the workplace, in order that they may make the best use of the control measures which are implemented.

This sheet forms part of the Good Practices Document on silica dust prevention, which is aimed specifically at the control of personal exposure to respirable crystalline silica dust in the workplace.

Access

- ✓ Restrict access to the working area to authorised personnel only.

Design and equipment

- ✓ Control raw material spillage. Make sure the right amount of raw material is used for the mould e.g. by providing a gauge.
- ✓ Enclose the filling/ unforming station as much as possible.
- ✓ Make the enclosure deep enough to contain equipment and materials.
- ✓ Keep the open area as small as possible – while allowing enough room for safe working. Use see-through panels and plastic strips to reduce the open area.
- ✓ The general airflow into the enclosure should typically be at least 0.5 m/s. The airflow towards the hood slots should typically be at least 1 m/s. Refer to task sheet 2.1.13.
- ✗ Do not store items inside the ventilated area; they will obstruct the airflow. Ensure large items do not obstruct the work opening.
- ✓ Where possible, locate the work area away from doors, windows and walkways to stop draughts interfering with the ventilation and spreading dust.
- ✓ Provide an air supply to the workroom to replace extracted air.
- ✓ Provide an easy way of checking the control is working, e.g. a manometer, pressure gauge or tell-tale (a small flag).
- ✓ Discharge extracted air to a safe place away from doors, windows and air inlets.
- ✓ You can re-circulate cleaned and filtered air into the workroom, in quantities recommended by existing standards.



Maintenance

- ✓ Ensure equipment used in the task is maintained as advised by the supplier/installer in efficient working order and in good repair.
- ✓ Replace consumables (filters etc.) in accordance with the manufacturer's recommendations.

Examination and testing

- ✓ Obtain information on the design performance of the ventilation equipment from the supplier. Keep this information to compare with future test results.
- ✓ Visually check all equipment at least once per week for signs of damage or, if it is in constant use, check it more frequently. If used infrequently, then check it before each use.
- ✓ Have the ventilation equipment examined and tested against its performance standard, at least once each year.
- ✓ Keep records of inspections for a suitable period of time which complies with national laws (minimum five years).

Cleaning and housekeeping

- ✓ Clean your workplace and equipment on a regular basis.
- ✓ Deal with spills immediately.
- ✓ Use vacuum or wet cleaning methods.
- X Do not clean up with a dry brush or using compressed air.**

Personal Protective Equipment

- ✓ Refer to task sheet 2.1.15 dedicated to Personal Protective Equipment.
- ✓ Risk assessment must be carried out to determine whether existing controls are adequate. If necessary, respiratory protective equipment (with the appropriate protection factor) should be provided and worn.
- ✓ Provide storage facilities to keep personal protective equipment clean, when not in use.
- ✓ Replace personal protective equipment at intervals recommended by the manufacturer/supplier.

Training

- ✓ Give your employees information on the health effects associated with respirable crystalline silica dust.
- ✓ Provide employees with training on: dust exposure prevention; checking controls are working and using them; when and how to use any respiratory protective equipment provided and what to do if something goes wrong. Refer to task sheet 2.1.19 and part 1 of the Good Practice Guide.

Supervision

- ✓ Have a system to check that control measures are in place and that they are being followed. Refer to task sheet 2.1.17.
- ✓ Employers should make sure that employees have all the means to perform the checklist given opposite.

Employee checklist for making the best use of the controls

- Make sure the ventilation system is switched on and is working.
- Make sure it is running properly; check the manometer, pressure gauge or tell-tale.
- Look for signs of damage, wear or poor operation of any equipment used. If you find any problems, tell your supervisor.
- If you think there is a problem with your dust control equipment, ensure additional control measures are taken to reduce exposure to respirable crystalline silica dust while the problem persists.
- Make sure that paper bags and other waste material aren't drawn into the ventilation duct.
- Make sure that large items do not obstruct the working opening.
- Remove broken products immediately from the work area.
- Put lids on containers immediately after use.
- Clear up spills immediately. Use vacuum cleaning or wet cleaning methods for solids. For liquids contain or absorb with granules or mats or wash away with a lot of water. Dispose of spills safely.
- Do not clean up with a dry brush or using compressed air.
- Use, maintain and store any respiratory protective equipment provided in accordance with instructions.

Jumbo bagging

This activity covers bagging operations for big (bulk) bags (500kg-1500kg) containing crystalline silica products, particularly dry materials.

This guidance sheet is aimed at employers to help them comply with the requirements of workplace health and safety legislation, by controlling exposure to respirable crystalline silica.

Specifically, this sheet provides good practice advice on dust control during the jumbo bag filling. Following the key points of this task sheet will help reduce exposure.

Depending on the specific circumstances of each case, it may not be necessary to apply all of the control measures identified in this sheet in order to minimize exposure to respirable crystalline silica.

i.e. to apply appropriate protection and prevention measures.

This document should also be made available to persons who may be exposed to respirable crystalline silica in the workplace, in order that they may make the best use of the control measures which are implemented.

This sheet forms part of the Good Practices Guide on silica dust prevention, which is aimed specifically at the control of personal exposure to respirable crystalline silica dust in the workplace.

Access

- ✓ Restrict access to the work area to authorised personnel only.

Design and equipment

- ✓ Ensure that bags and bag filling equipment are fit for purpose. When bagging flour products, the quality of bag stitching is crucial in preventing the emission of fine dust through the seams of the bags.
- ✓ The use of a bag with an inner plastic liner will help to reduce the emission of dust through bag seams.
- ✓ Use a bagging head in which the product passes down the centre and in which an annular ring is used for the purposes of dust extraction and for the removal of displaced air.
- ✓ The annular ring should be connected to a dust extraction unit (eg bag filter).
- ✓ Seal the bag collar onto the bagging head to prevent the escape of dust during bag filling. A strip of Velcro, a clamp or an inflatable bladder can be used for this purpose.
- ✓ Install bulk bagging equipment in a well-ventilated area. Outdoor installation (in an area protected from the rain) will help to reduce personal exposure to respirable crystalline silica by taking advantage of natural ventilation.
- ✓ When bagging flour products, consider the installation of a vibrator in the bagging head, to help loosen material from inside the bagging head prior to removal of each bag.
- ✓ When bagging flour products, consider the installation of a vibrating table beneath the bag in order to compact the material and improve stability during subsequent storage and transport.



Maintenance

- ✓ Ensure that the equipment used in this task is maintained as advised by the supplier/installer in efficient working order and in good repair.
- ✓ Replace consumables (filters etc) in accordance with the manufacturer's recommendations.

Examination and testing

- ✓ Visually check the equipment at least once per week for signs of damage or, if it is in constant use, check it more frequently. If used infrequently, then check it before each use.
- ✓ Obtain information on the design performance of the dust suppression and/or extraction equipment from the supplier. Keep this information to compare with future test results.
- ✓ Have the extraction equipment examined and tested against its performance standard, at least once each year.
- ✓ Keep records of inspections for a suitable period of time which complies with national laws (minimum five years).

Cleaning and housekeeping

- ✓ Clean your workplace on a regular basis.
- ✗ **Do not clean up with a dry brush or using compressed air.**
- ✓ Use vacuum or wet cleaning methods.
- ✓ Store bags in a safe place and dispose of empty bags safely.

Personal Protective Equipment

- ✓ Refer to task sheet 2.1.15 dedicated to Personal Protective Equipment.
- ✓ Risk assessment must be carried out to determine whether existing controls are adequate. If necessary, respiratory protective equipment (with the appropriate protection factor) should be provided and worn.
- ✓ Provide storage facilities to keep personal protective equipment clean when not in use.
- ✓ Replace respiratory protective equipment at intervals recommended by its suppliers.

Training

- ✓ Give your employees information on the health effects associated with respirable crystalline silica dust
- ✓ Provide employees with training on: dust exposure prevention; checking controls are working and using them; when and how to use any respiratory protective equipment provided and what to do if something goes wrong. Refer to task sheet 2.1.19 and part 1 of the Good Practice Guide.

Supervision

- ✓ Have a system to check that control measures are in place and that they are being followed. Refer to task sheet 2.1.17.
- ✓ Employers should make sure that employees have all the means to perform the checklist given opposite.

Employee checklist for making the best use of the controls

- Make sure the bagging machine is working properly.**
- Make sure the dust extraction system is switched on and that it is working correctly.**
- Look for signs of damage, wear or poor operation of any equipment used. If you find any problems, tell your supervisor.**
- If you think there is a problem with your dust control equipment, ensure additional control measures are taken to reduce exposure to respirable crystalline silica while the problem persists.**
- Make sure that bags are free of faults, especially the loops, inlet and outlet spouts and inner liner if used.**
- Clear up spills straight away. Use vacuum or wet cleaning methods.**
- Use, maintain and store any respiratory protective equipment provided in accordance with instructions.**

2.2.20

Knock-out and shake-out in foundries

This activity covers knock-out floor and shake-out floor in foundries.

This guidance sheet is aimed at employers to help them comply with the requirements of workplace health and safety legislation, by controlling exposure to respirable crystalline silica.

Specifically, this sheet provides advice on knock-out and shake-out in foundries. Following the key points of this task sheet will help reduce exposure.

Depending on the specific circumstances of each case, it may not be necessary to apply all of the control measures identified in this sheet in order to minimize exposure to respirable crystalline silica. i.e. to apply appropriate protection and prevention measures.

This document should also be made available to persons who may be exposed to respirable crystalline silica in the workplace, in order that they may make the best use of the control measures which are implemented.

This sheet forms part of the Good Practices Guide on silica dust prevention, which is aimed specifically at the control of personal exposure to respirable crystalline silica dust in the workplace.

Access

- ✓ Restrict access to the work area to authorised personnel only.

Design and equipment

- ✓ Respiratory protective equipment (RPE) is needed for manual knock-out.
- ✓ Control dust and fume with extracted knock-out tables, booths and attrition machinery.
- ✓ Where possible, fit flexible strips to the front of the shakeout enclosure.
- ✓ You need an air speed typically between 1 and 1.5 metres per second into the enclosure and at the down-draught knock-out table. Refer to task sheet 2.1.13.
- ✓ Always confirm that the extraction is turned on and working at the start of work. Check the gauge.
- ✓ Discharge cleaned, extracted air to a safe place outside the building, away from doors, windows and air inlets.
- ✓ Have a supply of clean air coming into the workroom to replace extracted air.
- ✓ To reduce exposures, have workers work to one side of the enclosure.
- ✓ Ensure workers stand away while rumbling is underway.
- ✓ Consult a qualified ventilation engineer to design new control systems

Maintenance

- ✓ Follow instructions in maintenance manuals.
- ✓ Keep equipment in effective and efficient working order.
- ✓ Repair faulty extraction systems immediately. Meanwhile, wear respiratory protective equipment (RPE).
- ✓ Sand is very abrasive and plant wears out quickly. Plan regular maintenance.

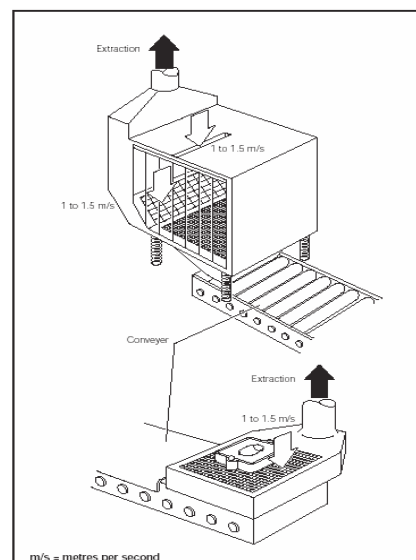

Examination and testing

- ✓ Look daily for signs of damage to the ducting, fan and air filter. Noisy or vibrating fans can indicate a problem. Repair damage immediately.
- ✓ At least once a week, check that the extraction system and gauge work properly.
- ✓ You need to know the manufacturer's performance specification to know if extraction is working properly.
- ✓ If this information isn't available, hire an engineer competent in ventilation techniques to determine its performance.
- ✓ The engineer's report must show the target air speeds.
- ✓ Keep this information in your testing logbook.
- ✓ Get an engineer competent in ventilation techniques to examine the system thoroughly and test its performance at least once every 12 months or obey national regulations.
- ✓ Keep records of inspections for a suitable period of time which complies with national laws (minimum five years).
- ✓ Review records to see if there are failure patterns that make planning maintenance easier.

Cleaning and housekeeping

- ✓ Every day, clear up accumulations of dirt in areas where people work all the time.
- ✓ Clean general workrooms once a week to stop dust being stirred up and to reduce slips.
- ✓ Use a vacuum cleaner fitted with a filter to clear up dust.
- X Don't clean up with a brush or with compressed air.
- ✓ Shovel large spills carefully to avoid stirring up dust.
- ✓ Deal with spills immediately. This needs coveralls, a respirator and single-use gloves.

Personal protective equipment (PPE)

- ✓ Refer to task sheet 2.1.15 dedicated to Personal Protective Equipment.
- ✓ Ask your safety-clothing supplier to help you get the right PPE.
- ✓ Respiratory protective equipment (RPE) is needed for manual knock-out, maintenance and cleaning, and for clearing up spills.
- ✓ Use a P3 standard of RPE (Assigned Protection Factor 20) or equivalent standard. Consult your supplier for advice.
- ✓ Replace RPE filters as recommended by your supplier. Throw away disposable masks after one use.
- ✓ Provide storage facilities to keep personal protective equipment clean when not in use.
- ✓ Protective gloves are needed to help prevent injuries.
- X Never allow compressed air use for removing dust from clothing

Training

- ✓ Give your employees information on the health effects associated with respirable crystalline silica dust.
- ✓ Provide employees with training on: dust exposure prevention; checking controls are working and using them; when and how to use any respiratory protective equipment provided and what to do if something goes wrong. Refer to task sheet 2.1.19 and part 1 of the Good Practice Guide.

Supervision

- ✓ Have a system to check that control measures are in place and that they are being followed. Refer to task sheet 2.1.17.
- ✓ Employers should make sure that employees have all the means to perform the check list given opposite.

Employee checklist for making the best use of the controls

- Make sure the room is well ventilated and any dust extraction system is switched on and is working.**
- Look for signs of damage, wear or poor operation of any equipment used, if you find any problems, tell your supervisor.**
- If you think there is a problem with your dust control equipment, ensure additional control measures are taken to reduce exposure to respirable crystalline silica dust while the problem persists.**
- Do not interface with ventilation systems – they are provided to protect your working environment.**
- Clean up using vacuum or wet cleaning methods.**
- Use, maintain and store any respiratory protective equipment provided in accordance with instructions.**

This guidance sheet is aimed at employers to help them comply with the requirements of workplace health and safety legislation, by controlling exposure to respirable crystalline silica.

Specially, this sheet provides advice on dust control when lining or break-out of refractory material in the workplace of foundries. Following the key points of this task sheet will help reduce exposure to an acceptable level. Depending on the specific circumstances of each case, it may not be necessary to apply all of the control measures identified in this sheet in order to minimize exposure to respirable crystalline silica. i.e. to apply appropriate protection and prevention measures.

This document should also be made available to persons who may be exposed to respirable crystalline silica in the workplace, in order that they may make the best use of the control measures which are implemented.

This sheet forms part of the Good Practices Document on silica dust prevention, which is aimed specifically at the control of personal exposure to respirable crystalline silica dust in the workplace.

Lining and break-out

This activity covers lining and break-out of refractory material in foundries.

Access

- ✓ Restrict access to the work area to authorised and trained personnel only.

Design and equipment

- ✓ Where practicable use pre-formed or “push out” linings to reduce dust generation.
- ✓ Use local exhaust ventilation, e.g. when fettling ladles, when practicable.

Maintenance

- ✓ Follow instructions in maintenance manuals.
- ✓ Keep equipment in effective and efficient working order.
- ✓ Repair faulty extraction systems immediately. Meanwhile, wear respiratory protective equipment (RPE).
- ✓ Plan regular maintenance.

Examination and testing

- ✓ Check visually the equipment before use. Noisy or vibrating fans can indicate a problem. Repair damage immediately.
- ✓ Check the extraction system and gauge work properly.
- ✓ You need to know the manufacturer's performance specification to know if extraction is working properly.
- ✓ If this information isn't available, hire a competent ventilation engineer to determine its performance.
- ✓ The engineer's report must show the target air speeds.
- ✓ Keep this information in your testing logbook.
- ✓ Get a competent ventilation engineer to examine the system thoroughly and test its performance at least once every 12 months or obey the national regulations.
- ✓ Keep records of all examinations and tests for at least five years.
- ✓ Review records to see if there are failure patterns that make planning maintenance easier.

Cleaning and housekeeping

- ✓ Clear up accumulations of dirt in areas where people work all the time.
- ✓ Use a vacuum cleaner fitted with a filter to clear up fine dust.
- X Shovel large spills carefully to avoid stirring up dust.
- ✓ Do not use dry brushing or compressed air.

Personal protective equipment

- ✓ Refer to task sheet 2.1.15 dedicated to PPE.
- ✓ Respiratory protective equipment (RPE) is normally needed for lining and break-out.
- ✓ Use positive pressure RPE with an Assigned Protection Factor (APF) of at least 40.
- ✓ Make sure all RPE is properly fit-tested – get advice from your supplier.
- ✓ Make sure that workers check their RPE works properly before use.
- ✓ Keep RPE clean and store it away from dust.
- ✓ Check the air flow and air quality to air-fed respiratory protective equipment at least every 3 months or before use.
- X **Never allow compressed air use for removing dust from clothing.**
- X **Workers must not take their coveralls home for washing. Use a contract laundry.**

Training

- ✓ Give your employees information on the health effects associated with respirable crystalline silica dust.
- ✓ Provide employees with training on: dust exposure prevention; checking controls are working and using them; when and how to use any respiratory protective equipment provided and what to do if something goes wrong. Refer to task sheet 2.1.19 and part 1 of the Good Practice Guide.

Supervision

- ✓ Check that the extraction is working properly; PPE is being used properly; and the rules on personal hygiene are being followed. Refer to task sheet 2.1.17.
- ✓ Employers should make sure that employees have all the means to perform the check list given opposite.

Employee checklist for making the best use of the controls

Make sure the room is well ventilated and any dust extraction system is switched on and is working.

Check your RPE and the clean air supply.

Look for signs of damage, wear or poor operation of any equipment used, If you find any problems, tell your supervisor.

If you think there is a problem with your dust control equipment, ensure additional control measures are taken to reduce exposure to respirable crystalline silica dust while the problem persists.

Do not interface with ventilation systems – they are provided to protect your working environment.

Clean up using vacuum or wet cleaning methods.

Use, maintain and store any respiratory protective equipment provided in accordance with instructions.

Mixing of materials

This sheet provides guidance on the design and use of equipment used for the mixing of products containing crystalline silica, particularly dry products.

This guidance sheet is aimed at employers to help them comply with the requirements of workplace health and safety legislation, by controlling exposure to respirable crystalline silica.

Specifically, this sheet provides advice on dust control when mixing materials containing crystalline silica dust. Following the key points of this task sheet will help reduce exposure. Depending on the specific circumstances of each case, it may not be necessary to apply all of the control measures identified in this sheet in order to minimize exposure to respirable crystalline silica. i.e. to apply appropriate protection and prevention measures.

This document should also be made available to persons who may be exposed to respirable crystalline silica in the workplace, in order that they may make the best use of the control measures which are implemented.

This sheet forms part of the Good Practices Guide on silica dust prevention, which is aimed specifically at the control of personal exposure to respirable crystalline silica dust in the workplace.

Access

- ✓ Restrict access to the work area to authorised personnel only.

Design and equipment

- ✓ Ensure that mixers are fit for purpose and that they are well maintained.
- ✓ Enclose mixers as much as possible.
- ✓ Mixer lids and other access points should be sealed to prevent the escape of dust.
- ✓ All covers and access doors must be securely closed before starting the mixer.
- ✓ The mixer charging point should be enclosed and provided with local exhaust ventilation.
- ✓ Alternatively, local exhaust ventilation can be supplied at points inside the lid or rear of the mixer casing, so that there is a net influx of air through the charging point and into the mixer.
- ✓ All extraction systems should be designed so as not to draw excessive amounts of raw material from the mixer.
- ✓ When producing a dry mix, consider arrangements for dust-free discharge of mixed products. eg direct discharge to an enclosed conveyor system. Alternatively, provide local exhaust ventilation at the discharge point.
- ✓ Local exhaust ventilation systems must be connected to a suitable dust extraction unit.
- ✓ Where possible, mixer charging points should be located away from doors, windows and walkways to prevent draughts affecting the performance of local exhaust ventilation systems.
- ✓ Provide a clean air supply to the workroom to replace extracted air.

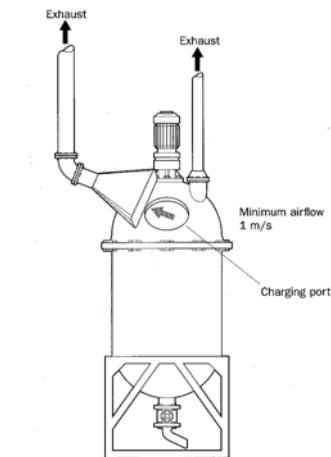

Maintenance

- ✓ Ensure equipment used in the task is maintained as advised by the supplier/installer in efficient working order and in good repair.
- ✓ Replace consumables (filters etc) in accordance with the manufacturer's recommendations.

Examination and testing

- ✓ Visually check the cleaning equipment for signs of damage at least once per week or, if it is in constant use, check it more frequently. If used infrequently, then check it before each use.
- ✓ Obtain information on the design performance of dust suppression and/or extraction equipment from the supplier. Keep this information to compare with future test results.
- ✓ Keep records of inspections for a suitable period of time which complies with national laws (minimum five years).

Cleaning and housekeeping

- ✓ Clean your workplace on a regular basis.
- ✓ Store containers in a safe place and dispose of empty containers safely.
- ✓ Put lids on containers immediately after use.
- ✓ Deal with spills immediately.
- ✗ **Do not clean up with a dry brush or using compressed air.**
- ✓ Use vacuum or wet cleaning methods.

Personal Protective Equipment

- ✓ Refer to task sheet 2.1.15 dedicated to Personal Protective Equipment.
- ✓ Risk assessment must be carried out to determine whether existing controls are adequate. If necessary, respiratory protective equipment (with the appropriate protection factor) should be provided and worn.
- ✓ Provide storage facilities to keep personal protective equipment clean when not in use.
- ✓ Replace respiratory protective equipment at intervals recommended by its suppliers.

Training

- ✓ Give your employees information on the health effects associated with respirable crystalline silica dust
- ✓ Provide employees with training on: dust exposure prevention; checking controls are working and using them; when and how to use any respiratory protective equipment provided and what to do if something goes wrong. Refer to task sheet 2.1.19 and part 1 of the Good Practice Guide.

Supervision

- ✓ Have a system to check that control measures are in place and that they are being followed. Refer to task sheet 2.1.17.
- ✓ Employers should make sure that employees have all the means to perform the checklist given opposite.

Employee checklist for making the best use of the controls

- ☐ **Make sure the work area is well ventilated and that any dust extraction system is switched on and is working correctly.**
- ☐ **Clear up spills straight away. Use vacuum or wet cleaning methods. Dispose of spills immediately.**
- ☐ **Look for signs of damage, wear or poor operation of any equipment used. If you find any problems, tell your supervisor.**
- ☐ **If you think there is a problem with your dust control equipment, ensure additional control measures are taken to reduce exposure to respirable crystalline silica dust while the problem persists.**
- ☐ **Use, maintain and store any respiratory protective equipment provided in accordance with instructions.**

Periodic and continuous drying

This activity relates to the drying of shaped fine and coarse ceramics made of materials containing crystalline silica.

This guidance sheet is aimed at employers to help them comply with the requirements of workplace health and safety legislation, by controlling exposure to respirable crystalline silica.

Specifically, this sheet provides good practice advice on dust control during drying of shaped fine and coarse ceramics made of materials containing crystalline silica. The drying process can be periodic or continuous. Following the key points of this task sheet will help reduce exposure. Depending on the specific circumstances of each case, it may not be necessary to apply all of the control measures identified in this sheet in order to minimize exposure to respirable crystalline silica. i.e. to apply appropriate protection and prevention measures.

This document should also be made available to persons who may be exposed to respirable crystalline silica in the workplace, in order that they may make the best use of the control measures which are implemented.

This sheet forms part of the Good Practices Document on silica dust prevention, which is aimed specifically at the control of personal exposure to respirable crystalline silica dust in the workplace.

Access

- ✓ Restrict access to the working area to authorised personnel only.

Design and equipment

- ✓ Good thermal insulation should be applied.
- ✓ Air knives should be applied to the entry and exit points to continuous dryers (to prevent vapour loss, contamination and dust emissions).
- ✓ Lights/signs should clearly indicate when the dryer is in use.
- ✓ Exhaust ventilation systems should be easily controllable, interlocked to the dryer heating controls and fitted with warning lights/alarms. Refer to task sheet 2.1.13.
- ✓ When the dryer is in use, the extraction should be balanced to a minimum level to maintain a slight negative pressure within the dryer.
- ✗ When feeding the dryer, avoid any friction of the products to be dried (design of transportation units).
- ✓ Where possible, locate the work area away from doors, windows and walkways to stop draughts interfering with the ventilation and spreading dust.
- ✓ Provide an air supply to the workroom to replace extracted air.
- ✓ Provide an easy way of checking the control is working, e.g. a manometer, pressure gauge or tell-tale (a small flag).
- ✓ Discharge extracted air to a safe place away from doors, windows and air inlets.
- ✗ Air re-circulation is not recommended.



Maintenance

- ✓ Ensure equipment used in the task is maintained as advised by the supplier/installer in efficient working order and in good repair.
- ✓ Replace consumables (filters etc.) in accordance with the manufacturer's recommendations.

Examination and testing

- ✓ Obtain information on the design performance of the ventilation equipment from the supplier. Keep this information to compare with future test results.
- ✓ Visually check all equipment at least once per week for signs of damage or, if it is in constant use, check it more frequently. If used infrequently, then check it before each use.
- ✓ Have the ventilation equipment examined and tested against its performance standard, at least once each year.
- ✓ Keep records of inspections for a suitable period of time which complies with national laws (minimum five years).

Cleaning and housekeeping

- ✓ Clean your workplace and equipment on a regular basis.
- ✓ Deal with spills immediately.
- ✓ Use vacuum or wet cleaning methods.
- X Do not clean up with a dry brush or using compressed air.**

Personal Protective Equipment

- ✓ Refer to task sheet 2.1.15 dedicated to Personal Protective Equipment.
- ✓ Risk assessment must be carried out to determine whether existing controls are adequate. If necessary, respiratory protective equipment (with the appropriate protection factor) should be provided and worn.
- ✓ Provide storage facilities to keep personal protective equipment clean, when not in use.
- ✓ Replace personal protective equipment at intervals recommended by the manufacturer/supplier.

Training

- ✓ Give your employees information on the health effects associated with respirable crystalline silica dust.
- ✓ Provide employees with training on: dust exposure prevention; checking controls are working and using them; when and how to use any respiratory protective equipment provided and what to do if something goes wrong. Refer to task sheet 2.1.19 and part 1 of the Good Practice Guide.

Supervision

- ✓ Have a system to check that control measures are in place and that they are being followed. Refer to task sheet 2.1.17.
- ✓ Employers should make sure that employees have all the means to perform the checklist given opposite.

Employee checklist for making the best use of the controls

- Make sure the ventilation system is switched on and is working.
- Make sure it is running properly; check the manometer, pressure gauge or tell-tale.
- Look for signs of damage, wear or poor operation of any equipment used. If you find any problems, tell your supervisor.
- If you think there is a problem with your dust control equipment, ensure additional control measures are taken to reduce exposure to respirable crystalline silica dust while the problem persists.
- Remove broken products immediately from feeding units.
- Clear up spills immediately. Use vacuum cleaning or wet cleaning methods. Dispose of spills safely.
- Do not clean up with a dry brush or using compressed air.
- Use, maintain and store any respiratory protective equipment provided in accordance with instructions.

Plastic Shaping - Ceramics

This activity relates to semi dry shaping of materials containing crystalline silica by different kinds of processes e.g. extrusion or pressing

This guidance sheet is aimed at employers to help them comply with the requirements of workplace health and safety legislation, by controlling exposure to respirable crystalline silica.

Specifically, this sheet provides good practice advice on dust control during plastic shaping of materials containing crystalline silica. Following the key points of this task sheet will help reduce exposure. Depending on the specific circumstances of each case, it may not be necessary to apply all of the control measures identified in this sheet in order to minimize exposure to respirable crystalline silica. i.e. to apply appropriate protection and prevention measures.

This document should also be made available to persons who may be exposed to respirable crystalline silica in the workplace, in order that they may make the best use of the control measures which are implemented.

This sheet forms part of the Good Practices Document on silica dust prevention, which is aimed specifically at the control of personal exposure to respirable crystalline silica dust in the workplace.

Access

- ✓ Restrict access to the working area to authorised personnel only.
- ✓ The work area and equipment should be clearly labelled.

Design and equipment

- ✓ Design the feed to the shaping device without the risk of dropping material to the work area.
- ✓ Provide conveyor belts to feed back clay chips to recycling.
- ✓ Installation should have sufficient free area to allow easy removing of fallen down material.
- ✓ Where possible, design surfaces of installations to avoid settling of waste material.
- ✓ Avoid drying of waste material; dispose it before drying in a proper container.
- ✓ Design surfaces of auxiliary devices (e.g. dryer palettes, boards) for an easy dust free cleaning.
- ✓ For shaping devices and activities which are relevant concerning dust emission, dust extraction should be provided.



Maintenance

- ✓ Ensure equipment used in the task is maintained as advised by the supplier/installer in efficient working order and in good repair.
- ✓ Replace consumables (filters etc.) in accordance with the manufacturer's recommendations.

Examination and testing

- ✓ Obtain information on the design performance of the ventilation equipment from the supplier. Keep this information to compare with future test results.
- ✓ Visually check all equipment at least once per week for signs of damage or, if it is in constant use, check it more frequently. If used infrequently, then check it before each use.
- ✓ Have the ventilation equipment examined and tested against its performance standard, at least once each year.
- ✓ Keep records of inspections for a suitable period of time which complies with national laws (minimum five years).

Cleaning and housekeeping

- ✓ Clean your workplace and equipment on a regular basis.
- ✓ Deal with spills immediately.
- ✓ Use vacuum or wet cleaning methods.
- X Do not clean up with a dry brush or using compressed air.**

Personal Protective Equipment

- ✓ Refer to task sheet 2.1.15 dedicated to Personal Protective Equipment.
- ✓ Risk assessment must be carried out to determine whether existing controls are adequate. If necessary, respiratory protective equipment (with the appropriate protection factor) should be provided and worn.
- ✓ Provide storage facilities to keep personal protective equipment clean, when not in use.
- ✓ Replace personal protective equipment at intervals recommended by the manufacturer/supplier.

Training

- ✓ Give your employees information on the health effects associated with respirable crystalline silica dust.
- ✓ Provide employees with training on: dust exposure prevention; checking controls are working and using them; when and how to use any respiratory protective equipment provided and what to do if something goes wrong. Refer to task sheet 2.1.19 and part 1 of the Good Practice Guide.

Supervision

- ✓ Have a system to check that control measures are in place and that they are being followed. Refer to task sheet 2.1.17.
- ✓ Employers should make sure that employees have all the means to perform the checklist given opposite.

Employee checklist for making the best use of the controls

- Make sure the ventilation system is switched on and is working.
- Make sure it is running properly; check the manometer, pressure gauge or tell-tale.
- Look for signs of damage, wear or poor operation of any equipment used. If you find any problems, tell your supervisor.
- If you think there is a problem with your dust control equipment, ensure additional control measures are taken to reduce exposure to respirable crystalline silica dust while the problem persists.
- Avoid drying of semi wet materials
- Clear up spills immediately. Use vacuum cleaning or wet cleaning methods for solids. Dispose of spills safely.
- Do not clean up with a dry brush or using compressed air.
- Use, maintain and store any respiratory protective equipment provided in accordance with instructions.

Preparation - Ceramics

This activity relates to semi dry preparation of materials containing crystalline silica by different kinds of processes e.g. crushing in pan mills, circular feeders or roller mills, storage in sourcing houses, box feeders or silos and mixing of additives

This guidance sheet is aimed at employers to help them comply with the requirements of workplace health and safety legislation, by controlling exposure to respirable crystalline silica.

Specifically, this sheet provides good practice advice on dust control during the semi dry preparation of materials containing crystalline silica by different kinds of processes. Following the key points of this task sheet will help reduce exposure. Depending on the specific circumstances of each case, it may not be necessary to apply all of the control measures identified in this sheet in order to minimize exposure to respirable crystalline silica. i.e. to apply appropriate protection and prevention measures.

This document should also be made available to persons who may be exposed to respirable crystalline silica in the workplace, in order that they may make the best use of the control measures which are implemented.

This sheet forms part of the Good Practices Document on silica dust prevention, which is aimed specifically at the control of personal exposure to respirable crystalline silica dust in the workplace.

Access

- ✓ Restrict access to the working area to authorised personnel only.
- ✓ The work area and equipment should be clearly labelled.

Design and equipment

- ✓ Installation should have sufficient traffic paths to allow easy cleaning and maintenance
- ✓ For machines and activities which are relevant concerning dust emission, dust extraction should be provided
- ✓ The mixing in from silos (ashes, slag) should be sufficiently protected by enclosures
- ✓ Where possible provide enclosure of silo discharge and dropping from conveyor belt
- ✓ Design any enclosure in sections to allow easy access for cleaning and maintenance.
- ✓ Where possible, locate the work area away from doors, windows and walkways to stop draughts interfering with the ventilation and spreading dust.
- ✓ Discharge extracted air to a safe place away from doors, windows and air inlets.
- ✓ You can re-circulate cleaned and filtered air into the workroom in quantities recommended by existing standards.



Maintenance

- ✓ Ensure equipment used in the task is maintained as advised by the supplier/installer in efficient working order and in good repair.
- ✓ Replace consumables (filters etc.) in accordance with the manufacturer's recommendations.

Examination and testing

- ✓ Obtain information on the design performance of the ventilation equipment from the supplier. Keep this information to compare with future test results.
- ✓ Visually check all equipment at least once per week for signs of damage or, if it is in constant use, check it more frequently. If used infrequently, then check it before each use.
- ✓ Have the ventilation equipment examined and tested against its performance standard, at least once each year.
- ✓ Keep records of inspections for a suitable period of time which complies with national laws (minimum five years).

Cleaning and housekeeping

- ✓ Clean your workplace and equipment on a regular basis.
- ✓ Deal with spills immediately.
- ✓ Use vacuum or wet cleaning methods.
- X Do not clean up with a dry brush or using compressed air.**

Personal Protective Equipment

- ✓ Refer to task sheet 2.1.15 dedicated to Personal Protective Equipment.
- ✓ Risk assessment must be carried out to determine whether existing controls are adequate. If necessary, respiratory protective equipment (with the appropriate protection factor) should be provided and worn.
- ✓ Provide storage facilities to keep personal protective equipment clean, when not in use.
- ✓ Replace personal protective equipment at intervals recommended by the manufacturer/supplier.

Training

- ✓ Give your employees information on the health effects associated with respirable crystalline silica dust.
- ✓ Provide employees with training on: dust exposure prevention; checking controls are working and using them; when and how to use any respiratory protective equipment provided and what to do if something goes wrong. Refer to task sheet 2.1.19 and part 1 of the Good Practice Guide.

Supervision

- ✓ Have a system to check that control measures are in place and that they are being followed. Refer to task sheet 2.1.17.
- ✓ Employers should make sure that employees have all the means to perform the checklist given opposite.

Employee checklist for making the best use of the controls

- Make sure the ventilation system is switched on and is working.
- Make sure it is running properly; check the manometer, pressure gauge or tell-tale.
- Look for signs of damage, wear or poor operation of any equipment used. If you find any problems, tell your supervisor.
- If you think there is a problem with your dust control equipment, ensure additional control measures are taken to reduce exposure to respirable crystalline silica dust while the problem persists.
- Clear up spills immediately. Use vacuum cleaning or wet cleaning methods for solids. Dispose of spills safely
- Use, maintain and store any respiratory protective equipment provided in accordance with instructions.

Preparing sand in foundries

This activity covers sand preparation in foundries.

This guidance sheet is aimed at employers to help them comply with the requirements of workplace health and safety legislation, by controlling exposure to respirable crystalline silica.

Specifically, this sheet provides advice on sand preparation in foundries. Following the key points of this task sheet will help reduce exposure.

Depending on the specific circumstances of each case, it may not be necessary to apply all of the control measures identified in this sheet in order to minimize exposure to respirable crystalline silica. i.e. to apply appropriate protection and prevention measures.

This document should also be made available to persons who may be exposed to respirable crystalline silica in the workplace, in order that they may make the best use of the control measures which are implemented.

This sheet forms part of the Good Practices Guide on silica dust prevention, which is aimed specifically at the control of personal exposure to respirable crystalline silica dust in the workplace.

Access

- ✓ Restrict access to the work area to authorised personnel only.

Design and equipment

- ✓ Stop dust spreading. If possible, segregate the sand plant from other operations.
- ✓ Enclose the sand plant as much as possible. Use flexible strips at the openings.
- ✓ You need an air speed typically between 1 and 1,5 meters per second into the sand plant enclosure. Refer to task sheet 2.1.13.
- ✓ Always confirm that the extraction is turned on and working at the start of work. Check the gauge.
- ✓ Discharge cleaned, extracted air to a safe place outside the building, away from doors, windows and air inlets.
- ✓ Have a supply of clean air coming into the workroom to replace extracted air.
- ✓ If you use a skid-steer loader ('bobcat') with the sand plant, respiratory protection can impair sight lines. Enclose the cab and supply filtered air. Change filters as advised by the supplier. Make sure the driver keeps the windows closed.
- ✓ Consult a qualified ventilation engineer to design new control.

Maintenance

- ✓ Follow instructions in maintenance manuals.
- ✓ Keep equipment in effective and efficient working order.
- ✓ Repair faulty extraction systems immediately. Meanwhile, wear respiratory protective equipment (RPE).
- ✓ Sand is very abrasive and plant wears out quickly. Plan regular maintenance.

Examination and testing

- ✓ Look daily for signs of damage to the ducting, fan and air filter. Noisy or vibrating fans can indicate a problem. Repair damage immediately.
- ✓ At least once a week, check that the extraction system and gauge work properly.
- ✓ You need to know the manufacturer's performance specification to know if extraction is working properly.
- ✓ If this information isn't available, hire an engineer competent in ventilation techniques to determine its performance.
- ✓ The engineer's report must show the target air speeds.
- ✓ Keep this information in your testing logbook.
- ✓ Get an engineer competent in ventilation techniques to examine the system thoroughly and test its performance at least once every 12 months or obey the national regulations.
- ✓ Keep records of inspections for a suitable period of time which complies with national laws (minimum five years).
- ✓ Review records to see if there are failure patterns that make planning maintenance easier.
- ✓ Consider risk assessment to decide the need for RPE and to make sure the controls are working well.

Cleaning and housekeeping

- ✓ Every day, clear up accumulations of dirt in areas where people work all the time.
- ✓ Clean general workrooms once a week to stop dust being stirred up and to reduce slips.
- ✓ Use a vacuum cleaner fitted with a filter to clear up fine dust.
- X Don't clean up with a brush or with compressed air.
- ✓ Shovel large spills carefully to avoid stirring up dust.

Personal protective equipment (PPE)

- ✓ Refer to task sheet 2.1.15 dedicated to Personal Protective Equipment.
- ✓ Ask your safety-clothing supplier to help you get the right PPE.
- ✓ Respiratory protective equipment (RPE) may be needed for work near the sand plant.
- ✓ RPE is needed for maintenance and cleaning.
- ✓ Use airline or powered filtering RPE for entry into the sand plant to clear blockages etc.
- ✓ Use a P3 standard of RPE (Assigned Protection Factor 20) or equivalent standard. Consult your supplier for advice.
- ✓ Replace RPE filters as recommended by your supplier.
- ✓ Provide storage facilities to keep personal protective equipment clean when not in use.
- ✓ Protective gloves are needed for maintenance and cleaning.
- X Never allow compressed air use for removing dust from clothing.
- X Workers must not take their coveralls home for washing. Use a contract laundry.

Training

- ✓ Give your employees information on the health effects associated with respirable crystalline silica dust.
- ✓ Provide employees with training on: dust exposure prevention; checking controls are working and using them; when and how to use any respiratory protective equipment provided and what to do if something goes wrong. Refer to task sheet 2.1.19 and part 1 of the Good Practice Guide.

Supervision

- ✓ Have a system to check that control measures are in place and that they are being followed. Refer to task sheet 2.1.17.
- ✓ Employers should make sure that employees have all the means to perform the check list given opposite.

Employee checklist for making the best use of the controls

- Make sure the room is well ventilated and any dust extraction system is switched on and is working.**

- Look for signs of damage, wear or poor operation of any equipment used, if you find any problems, tell your supervisor.**

- If you think there is a problem with your dust control equipment, ensure additional control measures are taken to reduce exposure to respirable crystalline silica dust while the problem persists.**

- Do not interface with ventilation systems – they are provided to protect your working environment.**

- Clean up using vacuum or wet cleaning methods.**

- Use, maintain and store any respiratory protective equipment provided in accordance with instructions.**

2.2.27a

Proportioning (small quantities) - Ceramics

This activity relates to proportioning of small quantities of dry materials containing crystalline silica by manual methods.

This guidance sheet is aimed at employers to help them comply with the requirements of workplace health and safety legislation, by controlling exposure to respirable crystalline silica.

Specifically, this sheet provides good practice advice on dust control during proportioning small quantities of materials containing dry crystalline silica by handwork. Following the key points of this task sheet will help reduce exposure. Depending on the specific circumstances of each case, it may not be necessary to apply all of the control measures identified in this sheet in order to minimize exposure to respirable crystalline silica. i.e. to apply appropriate protection and prevention measures.

This document should also be made available to persons who may be exposed to respirable crystalline silica in the workplace, in order that they may make the best use of the control measures which are implemented.

This sheet forms part of the Good Practices Document on silica dust prevention, which is aimed specifically at the control of personal exposure to respirable crystalline silica dust in the workplace.

Access

- ✓ Restrict access to the working area to authorised personnel only.

Design and equipment

- ✓ Enclose the weigh station as much as possible (see illustration).
- ✓ Make the enclosure deep enough to contain equipment and materials.
- ✓ Keep the open area as small as possible – while allowing enough room for safe working. Use see-through panels and plastic strips to reduce the open area.
- ✓ The general airflow into the enclosure should typically be at least 0,5 m/s. The airflow towards the hood slots should typically be at least 1 m/s. Refer to task sheet 2.1.13.
- ✗ Avoid using deep kegs or kegs / bags over 25 kg.
- ✓ Where possible, locate the work area away from doors, windows and walkways to stop draughts interfering with the ventilation and spreading dust.
- ✓ Provide an air supply to the workroom to replace extracted air.
- ✓ Provide an easy way of checking the control is working, e.g. a manometer, pressure gauge or tell-tale (a small flag).
- ✓ Discharge extracted air to a safe place away from doors, windows and air inlets.
- ✓ You can re-circulate cleaned and filtered air into the workroom in quantities recommended by existing standards.

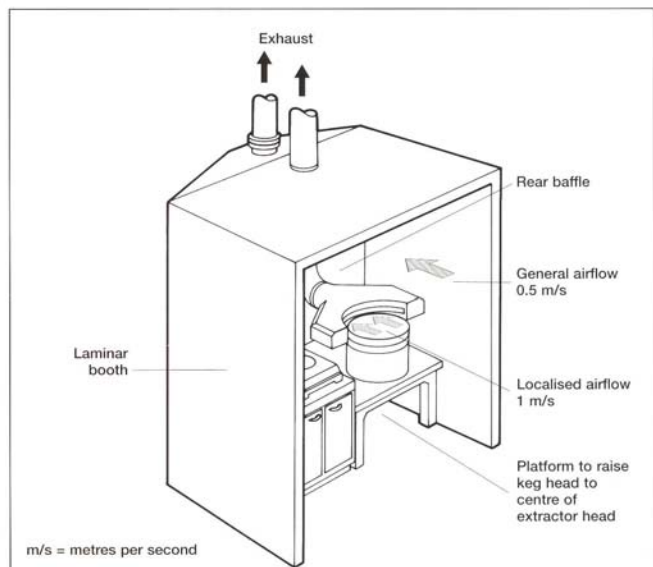

Maintenance

- ✓ Ensure equipment used in the task is maintained as advised by the supplier/installer in efficient working order and in good repair.
- ✓ Replace consumables (filters etc.) in accordance with the manufacturer's recommendations.

Examination and testing

- ✓ Obtain information on the design performance of the ventilation equipment from the supplier. Keep this information to compare with future test results.
- ✓ Visually check all equipment at least once per week for signs of damage or, if it is in constant use, check it more frequently. If used infrequently, then check it before each use.
- ✓ Have the ventilation equipment examined and tested against its performance standard, at least once each year.
- ✓ Keep records of inspections for a suitable period of time which complies with national laws (minimum five years).

Cleaning and housekeeping

- ✓ Clean your workplace and equipment on a regular basis.
- ✓ Deal with spills immediately.
- ✓ Use vacuum or wet cleaning methods.
- X **Do not clean up with a dry brush or using compressed air.**

Personal Protective Equipment

- ✓ Refer to task sheet 2.1.15 dedicated to Personal Protective Equipment.
- ✓ Risk assessment must be carried out to determine whether existing controls are adequate. If necessary, respiratory protective equipment (with the appropriate protection factor) should be provided and worn.
- ✓ Provide storage facilities to keep personal protective equipment clean, when not in use.
- ✓ Replace personal protective equipment at intervals recommended by the manufacturer/supplier.

Training

- ✓ Give your employees information on the health effects associated with respirable crystalline silica dust.
- ✓ Provide employees with training on: dust exposure prevention; checking controls are working and using them; when and how to use any respiratory protective equipment provided and what to do if something goes wrong. Refer to task sheet 2.1.19 and part 1 of the Good Practice Guide.

Supervision

- ✓ Have a system to check that control measures are in place and that they are being followed. Refer to task sheet 2.1.17.
- ✓ Employers should make sure that employees have all the means to perform the checklist given opposite.

Employee checklist for making the best use of the controls

- Make sure the ventilation system is switched on and is working.**
- Make sure it is running properly; check the manometer, pressure gauge or tell-tale.**
- Look for signs of damage, wear or poor operation of any equipment used. If you find any problems, tell your supervisor.**
- If you think there is a problem with your dust control equipment, ensure additional control measures are taken to reduce exposure to respirable crystalline silica dust while the problem persists.**
- Make sure that paper bags and other waste material aren't drawn into the ventilation duct.**
- Make sure that large items do not obstruct the working opening.**
- Put lids on containers immediately after use.**
- Clear up spills immediately. Use vacuum cleaning or wet cleaning methods. Dispose of spills safely**
- Do not clean up with a dry brush or using compressed air**
- Use, maintain and store any respiratory protective equipment provided in accordance with instructions.**

2.2.27b

Proportioning of bulk materials

This activity relates to proportioning of dry bulk materials containing crystalline silica out of silos or large volume feeders or big bags.

This guidance sheet is aimed at employers to help them comply with the requirements of workplace health and safety legislation, by controlling exposure to respirable crystalline silica.

Specifically, this sheet provides good practice advice on dust control during proportioning medium and large quantities of materials containing crystalline silica. Following the key points of this task sheet will help reduce exposure. Depending on the specific circumstances of each case, it may not be necessary to apply all of the control measures identified in this sheet in order to minimize exposure to respirable crystalline silica. i.e. to apply appropriate protection and prevention measures.

This document should also be made available to persons who may be exposed to respirable crystalline silica in the workplace, in order that they may make the best use of the control measures which are implemented.

This sheet forms part of the Good Practices Document on silica dust prevention, which is aimed specifically at the control of personal exposure to respirable crystalline silica dust in the workplace.

Access

- ✓ Restrict access to the working area to authorised personnel only.
- ✓ The work area and equipment should be clearly labelled.

Design and equipment

- ✓ Ensure dust-tight connections between feed hopper, load cell and receiving container.
- ✓ Provide a controlled feeding device between the feed hopper and load cell.
- ✓ Provide as much space as possible within the enclosures. This will help contain the dust.
- ✓ Consider how to prevent or deal with blockages without breaching the integrity of the closed system, eg vibrating pads or pneumatic jets.
- ✓ Design the enclosure in sections to allow easy access for cleaning and maintenance.
- * Do not allow entry to a feed hopper to remove a blockage without isolating the equipment, checking the atmosphere for oxygen deficiency and selecting suitable personal protective equipment.
- ✓ Keep the process equipment under negative pressure to prevent leaks.
- ✓ Discharge extracted air to a safe place away from doors, windows and air inlets.



Maintenance

- ✓ Ensure equipment used in the task is maintained as advised by the supplier/installer in efficient working order and in good repair.
- ✓ Adopt a “permit to work” system for maintenance work.
- ✓ Replace consumables (filters etc.) in accordance with the manufacturer’s recommendations.

Examination and testing

- ✓ Obtain information on the design performance of the ventilation equipment from the supplier. Keep this information to compare with future test results.
- ✓ Visually check all equipment at least once per week for signs of damage or, if it is in constant use, check it more frequently. If used infrequently, then check it before each use.
- ✓ Have the ventilation equipment examined and tested against its performance standard, at least once each year.
- ✓ Keep records of inspections for a suitable period of time which complies with national laws (minimum five years).

Cleaning and housekeeping

- ✓ Clean your workplace and equipment on a regular basis.
- ✓ Deal with spills immediately.
- ✓ Use vacuum or wet cleaning methods.
- X Do not clean up with a dry brush or using compressed air.**

Personal Protective Equipment

- ✓ Refer to task sheet 2.1.15 dedicated to Personal Protective Equipment.
- ✓ Risk assessment must be carried out to determine whether existing controls are adequate. If necessary, respiratory protective equipment (with the appropriate protection factor) should be provided and worn.
- ✓ Provide storage facilities to keep personal protective equipment clean, when not in use.
- ✓ Replace personal protective equipment at intervals recommended by the manufacturer/supplier.

Training

- ✓ Give your employees information on the health effects associated with respirable crystalline silica dust.
- ✓ Provide employees with training on: dust exposure prevention; checking controls are working and using them; when and how to use any respiratory protective equipment provided and what to do if something goes wrong. Refer to task sheet 2.1.19 and part 1 of the Good Practice Guide.

Supervision

- ✓ Have a system to check that control measures are in place and that they are being followed. Refer to task sheet 2.1.17.
- ✓ Employers should make sure that employees have all the means to perform the checklist given opposite.

Employee checklist for making the best use of the controls

- Make sure any extraction system is switched on and is working.
- Look for signs of leaks, wear or damage of any equipment used. If you find any problems, tell your supervisor.
- If you think there is a problem with your dust control equipment, ensure additional control measures are taken to reduce exposure to respirable crystalline silica dust while the problem persists.
- Put lids on containers immediately after use.
- Clear up spills immediately. Use vacuum cleaning or wet cleaning methods. Dispose of spills safely
- Do not clean up with a dry brush or using compressed air.
- Use, maintain and store any respiratory protective equipment provided in accordance with instructions.
- Follow any special procedures that are needed before the system is opened or entered, e.g. purging and washing

Quarry mobile plant - excavation & haulage

Large quantities of airborne dust may be generated by the operation of mobile plant in quarries. Dust is generated during mineral extraction and loading operations and during movement of vehicles across the quarry floor and on haul roads.

This guidance sheet is aimed at employers to help them comply with the requirements of workplace health and safety legislation, by controlling exposure to respirable crystalline silica.

Specifically, this sheet provides advice on the design and use of mobile plant in a quarry. Following the key points of this task sheet will prevent personal exposure to the dust released into the air during quarry mobile plant operations, including excavation and haulage. Depending on the specific circumstances of each case, it may not be necessary to apply all of the control measures identified in this sheet in order to minimize exposure to respirable crystalline silica. i.e. to apply appropriate protection and prevention measures.

This document should also be made available to persons who may be exposed to respirable crystalline silica in the workplace, in order that they may make the best use of the control measures which are implemented.

This sheet forms part of the Good Practices Guide on silica dust prevention, which is aimed specifically at the control of personal exposure to respirable crystalline silica dust in the workplace.

Access

- ✓ Restrict access to the work area to authorised personnel only.

Design and equipment

- ✓ Little can be done to prevent the generation of airborne dust during activities using mobile plant, so control of exposure relies upon enclosure of the machine operator in an enclosed, sealed cab.
- ✓ The cab should be equipped with air conditioning or fresh air supply, fitted with an air filter that is designed to withstand a high loading of respirable dust particles.
- ✓ In order for the air conditioning system or fresh air supply to provide the greatest protection from dust exposure, the doors and windows of the cab must be kept closed at all times while the machine is in operation. This will help to maintain the cab under positive pressure.
- ✓ Where possible, timing of extraction operations, to coincide with the wetter seasons of the year, will help to reduce airborne dust generation.
- ✓ In dry weather, use spray mist dust suppression in order to help reduce airborne dust generation. Rippers may be fitted with a mist boom mounted on the ripper/shank mechanism.



Maintenance

- ✓ Maintain the air conditioning system as advised by the supplier, in effective and efficient working order.
- ✓ The air conditioning filter should be changed each time it is deemed necessary and at least at intervals advised by the manufacturer.

Examination and testing

- ✓ Machine drivers must check that the air conditioning system is working within accepted parameters.
- ✓ Machine operators should check the condition of the filter (usually located behind the driver's seat) as recommended by the manufacturer.
- ✓ Any faults with the air conditioning/filtration system must be reported as soon as possible so that remedial action can be taken.

Cleaning and housekeeping

- ✓ A build up of fine dust on the internal surfaces of the driver's cab might suggest a problem with the air conditioning system.
- ✓ Preference should be given to the use of vacuum or wet cleaning methods. Avoid using a dry brush when cleaning the internal surfaces of the driver's cab.

Personal Protective Equipment

- ✓ Refer to task sheet 2.1.15 dedicated to Personal Protective Equipment.
- ✓ Risk assessment must be carried out to check the effectiveness of control measures. Respiratory protective equipment (with the appropriate protection factor) may need to be worn temporarily in the event control measures fail.
- ✓ Provide storage facilities to keep personal protective equipment clean when not in use.
- ✓ Replace respiratory protective equipment at intervals recommended by its suppliers.

Training

- ✓ Give your employees information on the health effects associated with respirable crystalline silica dust
- ✓ Provide employees with training on: dust exposure prevention; checking controls are working and using them; when and how to use any respiratory protective equipment provided and what to do if something goes wrong. Refer to task sheet 2.1.19 and part 1 of the Good Practice Guide.

Supervision

- ✓ Have a system to check that dust control measures are in place and that they are being followed. Refer to task sheet 2.1.17.
- ✓ Employers should make sure that employees have all the means to perform the checklist given opposite.

Employee checklist for making the best use of the controls

- Keep the cab doors and windows closed at all times when the machine is in operation.
- Monitor the performance of the air conditioning system each time the machine is used.
- Check the condition of the air filter once a week.
- Keep records of all safety checks on a daily check sheet.
- Look for signs of dust build up on the surfaces of the cab. This may be a sign that the air filter is in poor condition.
- If you think there is a problem with your dust control equipment, ensure additional control measures are taken to reduce exposure to respirable crystalline silica while the problem persists.
- Keep the interior of the cabin clean.
- Use, maintain and store any respiratory protective equipment provided in accordance with instructions.

Screening

This activity covers the dry screening of products containing crystalline silica.

This guidance sheet is aimed at employers to help them comply with the requirements of workplace health and safety legislation, by controlling exposure to respirable crystalline silica.

Specifically, this sheet provides advice on dust control for dry screening operations. Following the key points of this task sheet will help reduce exposure.

Depending on the specific circumstances of each case, it may not be necessary to apply all of the control measures identified in this sheet in order to minimize exposure to respirable crystalline silica.

i.e. to apply appropriate protection and prevention measures.

This document should also be made available to persons who may be exposed to respirable crystalline silica in the workplace, in order that they may make the best use of the control measures which are implemented.

This sheet forms part of the Good Practices Guide on silica dust prevention, which is aimed specifically at the control of personal exposure to respirable crystalline silica dust in the workplace.

Access

- ✓ Restrict access to the work area to authorised personnel only.

Design and equipment

- ✓ Ensure the dry screening equipment is fit for purpose and that it is well maintained.
- ✓ Screens should be enclosed as far as possible.
- ✓ Screen enclosures should be connected to a suitable dust extraction system (e.g. bag filter/cyclone/scrubber).
- ✓ Flexible hoses should be used to connect screen enclosures to the extraction system. These hoses must be durable (due to the constant motion of the screen) and must be properly sealed onto the screen enclosure. Any gaps will reduce performance of the extraction system and result in dust emissions into the workplace air.
- ✓ Transfer points, between screens and conveyors, should be sealed as far as possible and served with dust extraction systems.
- ✓ Ensure that screening equipment is designed and installed so as to be easily accessible for maintenance work.
- ✓ Control cabins should have their own clean air supply. Where necessary, they should be fitted with forced air filtration and maintained under positive pressure to prevent the ingress of dusty air.
- ✓ Screens should be equipped with lifting aids for use when lifting and positioning new screens.



Maintenance

- ✓ Ensure equipment used in the task is maintained as advised by the supplier/installer in efficient working order and in good repair.
- ✓ Replace consumables (filters etc) in accordance with the manufacturer's recommendations.

Examination and testing

- ✓ Visually check the equipment at least once per week for signs of damage or, if it is in constant use, check it more frequently. If used infrequently, then check it before each use.
- ✓ Obtain information on the design performance of the dust suppression and/or extraction equipment from the supplier. Keep this information to compare with future test results.
- ✓ Keep records of inspections for a suitable period of time which complies with national laws (minimum five years).
- ✓ Check on a regular basis that extraction ducting and flexible hoses are not obstructed.

Cleaning and housekeeping

- ✓ Clean your workplace on a regular basis.
- ✗ **Do not clean up with a dry brush or using compressed air.**
- ✓ Use vacuum or wet cleaning methods

Personal Protective Equipment

- ✓ Refer to task sheet 2.1.15 dedicated to Personal Protective Equipment.
- ✓ Risk assessment must be carried out to determine whether existing controls are adequate. If necessary, respiratory protective equipment (with the appropriate protection factor) should be provided and worn.
- ✓ Provide storage facilities to keep personal protective equipment clean when not in use.
- ✓ Replace respiratory protective equipment at intervals recommended by its suppliers.

Training

- ✓ Give your employees information on the health effects associated with respirable crystalline silica dust
- ✓ Provide employees with training on: dust exposure prevention; checking controls are working and using them; when and how to use any respiratory protective equipment provided and what to do if something goes wrong. Refer to task sheet 2.1.19 and part 1 of the Good Practice Guide.

Supervision

- ✓ Have a system to check that control measures are in place and that they are being followed. Refer to task sheet 2.1.17.
- ✓ Employers should make sure that employees have all the means to perform the checklist given opposite.

Employee checklist for making the best use of the controls

- Make sure the screening equipment is working properly.**
- Make sure the dust extraction system is switched on and is working correctly.**
- Check that screen enclosures are securely connected to the extraction system and that the flexible hoses are in good condition.**
- Look for signs of damage, wear or poor operation of any equipment used. If you find any problems, tell your supervisor.**
- If you think there is a problem with your dust control equipment, ensure additional control measures are taken to reduce exposure to respirable crystalline silica while the problem persists.**
- Use handling aids when available.**
- Clear up spills straight away. Use vacuum or wet cleaning methods.**
- Clean up control rooms using vacuum or wet cleaning methods.**
- Use, maintain and store any respiratory protective equipment provided in accordance with instructions.**

Shot-blasting in foundries

This activity covers shot-blasting plant in foundries.

This guidance sheet is aimed at employers to help them comply with the requirements of workplace health and safety legislation, by controlling exposure to respirable crystalline silica.

Specifically, this sheet provides advice on shot-blasting plant in foundries. Following the key points of this task sheet will help reduce exposure.

Depending on the specific circumstances of each case, it may not be necessary to apply all of the control measures identified in this sheet in order to minimize exposure to respirable crystalline silica. i.e. to apply appropriate protection and prevention measures.

This document should also be made available to persons who may be exposed to respirable crystalline silica in the workplace, in order that they may make the best use of the control measures which are implemented.

This sheet forms part of the Good Practices Guide on silica dust prevention, which is aimed specifically at the control of personal exposure to respirable crystalline silica dust in the workplace.

Access

- ✓ Restrict access to the work area to authorised personnel only.

Design and equipment

- ✓ Use a fully enclosed cabinet or booth for shotblasting, held under negative pressure.
- ✓ For shot blasting, use material containing a maximum of 2% crystalline silica, or such lower value as may be stipulated in national regulations.
- ✓ Ensure a pressure gauge is fitted and interlocked with the blasting medium supply.
- ✓ You need a high standard of filtration for the air discharged from the booth.
- ✓ Discharge filtered air outside the building, away from doors, windows and air inlets.
- ✓ Place the booth carefully to make loading and unloading easy.
- ✓ Run the booth for two minutes after blasting has ceased to clear the air.

Maintenance

- ✓ Follow instructions in maintenance manuals.
- ✓ Use a written system of work for maintenance and define the PPE necessary.
- ✓ Keep equipment in effective and efficient working order.
- ✓ If the extraction system is faulty, stop work until it is repaired.
- ✓ Abrasives wear out plant quickly. Plan regular maintenance

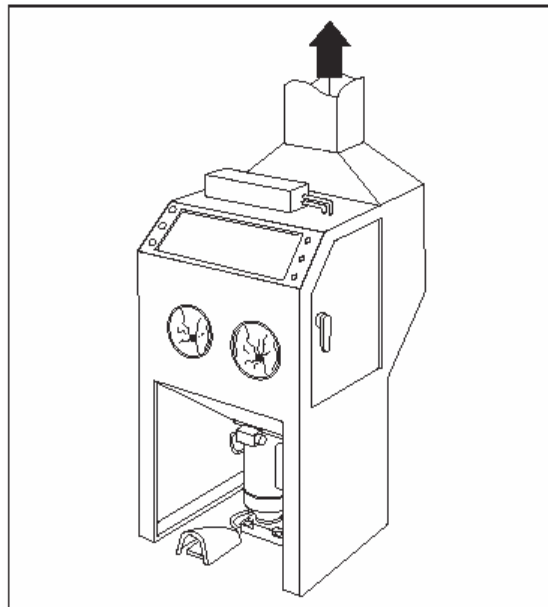

Examination and testing

- ✓ Look daily for signs of damage to the ducting, fan and air filter. Noisy or vibrating fans can indicate a problem. Repair damage immediately.
- ✓ At least once a week, check that the extraction system and gauge work properly, with no dust leaks.
- ✓ You need to know the manufacturer's performance specification to know if extraction is working properly.
- ✓ If this information isn't available, hire an engineer competent in ventilation techniques to determine its performance.
- ✓ The engineer's report must show the target air speeds.
- ✓ Keep this information in your testing logbook.
- ✓ Get an engineer competent in ventilation techniques to examine the system thoroughly and test its performance at least once every 12 months or obey the national regulations.
- ✓ Keep records of inspections for a suitable period of time which complies with national laws (minimum five years).
- ✓ Review records to see if there are failure patterns that make planning maintenance easier.

Cleaning and housekeeping

- ✓ Every day, clear up accumulations of dirt in areas where people work all the time.
- ✓ Clean general workrooms once a week to stop dust being stirred up and to reduce slips.
- ✓ Use a vacuum cleaner fitted with a filter to clear up dust.
- ✓ Don't clean up with a brush or with compressed air
- ✓ Deal with spills immediately. This needs coveralls, a respirator and single-use gloves.
- ✓ Store containers in a safe place.
- ✓ Keep lids on containers when they are not being filled or emptied.
- ✓ Dispose of wastes safely.

Personal protective equipment

- ✓ Refer to task sheet 2.1.15 dedicated to Personal Protective Equipment.
 - ✓ Ask your safety-clothing supplier to help you get the right PPE.
 - ✓ Respiratory protective equipment (RPE) should not be needed if the extraction is designed correctly and working properly.
 - ✓ RPE is needed for maintenance and cleaning, and for clearing up spills.
 - ✓ Use a P3 standard of RPE (Assigned Protection Factor 20) or equivalent standard. Consult your supplier for advice.
 - ✓ Replace RPE filters as recommended by your supplier. Throw away disposable masks after one use.
 - ✓ Provide storage facilities to keep personal protective equipment clean when not in use.
- X Never use compressed air use for removing dust from clothing.**
- X Workers must not take their coveralls home for washing. Use a contract laundry.**

Training

- ✓ Give your employees information on the health effects associated with shot blasting and respirable crystalline silica.
- ✓ Provide employees with training on: dust exposure prevention; checking controls are working and using them; when and how to use any respiratory protective equipment provided and what to do if something goes wrong. Refer to task sheet 2.1.19 and part 1 of the Good Practice Guide.

Supervision

- ✓ Have a system to check that control measures are in place and that they are being followed. Refer to task sheet 2.1.17.
- ✓ Employers should make sure that employees have all the means to perform the check list given opposite.

Employee checklist for making the best use of the controls

- Make sure the room is well ventilated and any dust extraction system is switched on and is working.**
- Look for signs of damage, wear or poor operation of any equipment used, if you find any problems, tell your supervisor.**
- If you think there is a problem with your dust control equipment, ensure additional control measures are taken to reduce exposure to respirable crystalline silica dust while the problem persists.**
- Do not interface with ventilation systems – they are provided to protect your working environment.**
- Clean up using vacuum or wet cleaning methods.**
- Use, maintain and store any respiratory protective equipment provided in accordance with instructions.**

2.2.31a

Small bag filling – coarse products

This activity covers bagging operations for small bags (15kg-50kg) with dry products containing crystalline silica.

This sheet is only relevant to products in which the grains have not been ground down to flour. The bagging of flours is covered in sheet 2.2.31.b.

This guidance sheet is aimed at employers to help them comply with the requirements of workplace health and safety legislation, by controlling exposure to respirable crystalline silica.

Specifically, this sheet provides advice on dust control during the filling of small bags with coarse products. Following the key points of this task sheet will help reduce exposure.

Depending on the specific circumstances of each case, it may not be necessary to apply all of the control measures identified in this sheet in order to minimize exposure to respirable crystalline silica. i.e. to apply appropriate protection and prevention measures.

This document should also be made available to persons who may be exposed to respirable crystalline silica in the workplace, in order that they may make the best use of the control measures which are implemented.

This sheet forms part of the Good Practices Guide on silica dust prevention, which is aimed specifically at the control of personal exposure to respirable crystalline silica in the workplace.

Access

- ✓ Restrict access to the work area to authorised personnel only.

Design and equipment

- ✓ Ensure that bags and bag filling equipment are fit for purpose. The quality of the bags is crucial to preventing leakage of dust through the bag seams.
- ✓ Use bagging heads in which the product passes down the centre and in which an outer, annular ring is used for the purposes of dust extraction and for the removal of displaced air. The outer, annular ring should be connected to a dust extraction unit (eg bag filter).
- ✓ Ensure that bags are effectively clamped/sealed onto the bagging head during bag filling to prevent the escape of dust.
- ✓ Position the bagging head inside a dust extraction hood which is enclosed as much as possible.
- ✓ The dust extraction system serving the hood must have sufficient capture velocity to prevent the escape of dust emitted through the bag seams and dust discharged from the bagging head when the bag is removed. Refer to task sheet 2.1.13.
- ✓ Bags must be sealed shut as soon as they are removed from the bagging head. Bags with self-sealing valves are available or, alternatively, bag stitching or heat sealing techniques may be used.
- ✓ Consider mechanical/pneumatic assistance with bag handling.
- ✓ In automated bagging systems, the use of a carousel system enables many bags to be filled simultaneously at a very slow rate using a screw feed. When bags are filled slowly, less dust is emitted.



Maintenance

- ✓ Ensure equipment used in the task is maintained as advised by the supplier/installer in efficient working order and in good repair.
- ✓ Replace consumables (filters etc) in accordance with the manufacturer's recommendations.

Examination and testing

- ✓ Visually check the equipment at least once per week for signs of damage or, if it is in constant use, check it more frequently. If used infrequently, then check it before each use.
- ✓ Obtain information on the design performance of the dust suppression and/or extraction equipment from the supplier. Keep this information to compare with future test results.
- ✓ Keep records of inspections for a suitable period of time which complies with national laws (minimum five years).

Cleaning and housekeeping

- ✓ Clean your workplace on a regular basis.
- ✗ **Do not clean up with a dry brush or using compressed air.**
- ✓ Use vacuum or wet cleaning methods.
- ✓ Store bags in a safe place and dispose of empty bags safely.

Personal Protective Equipment

- ✓ Refer to task sheet 2.1.15 dedicated to Personal Protective Equipment.
- ✓ Risk assessment must be carried out to determine whether existing controls are adequate. If necessary, respiratory protective equipment (with the appropriate protection factor) should be provided and worn.
- ✓ Provide storage facilities to keep personal protective equipment clean when not in use.
- ✓ Replace respiratory protective equipment at intervals recommended by its suppliers.

Training

- ✓ Give your employees information on the health effects associated with respirable crystalline silica dust
- ✓ Provide employees with training on: dust exposure prevention; checking controls are working and using them; when and how to use any respiratory protective equipment provided and what to do if something goes wrong. Refer to task sheet 2.1.19 and part 1 of the Good Practice Guide.

Supervision

- ✓ Have a system to check that control measures are in place and that they are being followed. Refer to task sheet 2.1.17.
- ✓ Employers should make sure that employees have all the means to perform the checklist given opposite.

Employee checklist for making the best use of the controls

- ☐ **Make sure that the bagging machine is working properly.**
- ☐ **Make sure that bags are free from defects, especially as regards valve construction.**
- ☐ **Make sure that the dust extraction system is switched on and is working correctly.**
- ☐ **Look for signs of damage, wear or poor operation of any equipment used. If you find any problems, tell your supervisor.**
- ☐ **If you think there is a problem with your dust control equipment, ensure additional control measures are taken to reduce exposure to respirable crystalline silica while the problem persists.**
- ☐ **Even if it is not normally necessary for you to wear a dust mask, it may be necessary for you to wear one temporarily in the event of a spillage or if other control measures fail.**
- ☐ **Clear up spills straight away. Use vacuum or wet cleaning methods.**
- ☐ **Use, maintain and store any respiratory protective equipment provided in accordance with instructions.**
- ☐ **Use handling aids when available.**

2.2.31b

Small bag filling - flours

This activity covers bagging operations for small bags (15kg-50kg) with dry products containing crystalline silica.

This sheet is only relevant to the non-automated bagging of flours (products in which the grains have been ground down to a fine powder). The bagging of coarse products is covered by sheet 2.2.31a.

This guidance sheet is aimed at employers to help them comply with the requirements of workplace health and safety legislation, by controlling exposure to respirable crystalline silica.

Specifically, this sheet provides advice on dust control during the filling of small bags with flour products. Following the key points of this task sheet will help reduce exposure.

Depending on the specific circumstances of each case, it may not be necessary to apply all of the control measures identified in this sheet in order to minimize exposure to respirable crystalline silica. i.e. to apply appropriate protection and prevention measures.

This document should also be made available to persons who may be exposed to respirable crystalline silica in the workplace, in order that they may make the best use of the control measures which are implemented.

This sheet forms part of the Good Practices Guide on silica dust prevention, which is aimed specifically at the control of personal exposure to respirable crystalline silica in the workplace.

Access

- ✓ Restrict access to the work area to authorised personnel only.

Design and equipment

- ✓ Ensure that bags and bag filling equipment are fit for purpose. The quality of the bags is crucial to preventing leakage of dust through the bag seams.
- ✓ Consideration should be given to screw bag filling, rather than combined rotary impellor / air packing. The screw filling method will reduce the problem of having to remove entrained dusty air from the bags.
- ✓ Flour products should be conditioned prior to bag filling. By leaving the flour to settle inside the storage silo, the material will become compacted thus removing entrained air. Conditioning in this way will ensure a more consistent bulk density, facilitating better control of the bagging process.
- ✓ When designing hoppers for effective product conditioning, consideration will need to be given to height constraints.
- ✓ Ensure that bags are effectively clamped/sealed onto the bagging head during bag filling to prevent the escape of dust.
- ✓ Position the bagging head inside a dust extraction hood which is enclosed as much as possible. Refer to task sheet 2.1.13.
- ✓ The dust extraction system serving the hood must have sufficient capture velocity to prevent the escape of any dust emitted through the bag seams and dust discharged from the bagging head when the bag is removed.
- ✓ Bags must be sealed shut as soon as they are removed from the bagging head. Bags with self-sealing valves are available or, alternatively, bag stitching techniques may be used.
- ✓ Consider mechanical/pneumatic assistance with bag handling.
- ✓ When bagging silica flour products, consideration should be given to full or partial automation of the process in order to prevent personal exposure to respirable crystalline silica dust.
- ✓ In automated bagging systems, the use of a carousel system enables many bags to be filled simultaneously at a very slow rate using a screw feed. When bags are filled slowly, less dust is emitted.



Maintenance

- ✓ Ensure equipment used in the task is maintained as advised by the supplier/installer in efficient working order and in good repair.
- ✓ Replace consumables (filters etc) in accordance with the manufacturer's recommendations.

Examination and testing

- ✓ Visually check the equipment at least once per week for signs of damage or, if it is in constant use, check it more frequently. If used infrequently, then check it before each use.
- ✓ Obtain information on the design performance of the dust suppression and/or extraction equipment from the supplier. Keep this information to compare with future test results.
- ✓ Keep records of inspections for a suitable period of time which complies with national laws (minimum five years).

Cleaning and housekeeping

- ✓ Clean your workplace on a regular basis.
- ✗ **Do not clean up with a dry brush or using compressed air.**
- ✓ Use vacuum or wet cleaning methods.
- ✓ Store bags in a safe place and dispose of empty bags safely.

Personal Protective Equipment

- ✓ Refer to task sheet 2.1.15 dedicated to Personal Protective Equipment.
- ✓ Risk assessment must be carried out to determine whether existing controls are adequate. If necessary, respiratory protective equipment (with the appropriate protection factor) should be provided and worn.
- ✓ Provide storage facilities to keep personal protective equipment clean when not in use.
- ✓ Replace respiratory protective equipment at intervals recommended by its suppliers.

Training

- ✓ Give your employees information on the health effects associated with respirable crystalline silica dust
- ✓ Provide employees with training on: dust exposure prevention; checking controls are working and using them; when and how to use any respiratory protective equipment provided and what to do if something goes wrong. Refer to task sheet 2.1.19 and part 1 of the Good Practice Guide.

Supervision

- ✓ Have a system to check that control measures are in place and that they are being followed. Refer to task sheet 2.1.17.
- ✓ Employers should make sure that employees have all the means to perform the checklist given opposite.

Employee checklist for making the best use of the controls

- Make sure that the bagging machine is working properly.**
- Make sure that bags are free from defects, especially as regards valve construction.**
- Make sure that the dust extraction system is switched on and is working correctly.**
- Look for signs of damage, wear or poor operation of any equipment used. If you find any problems, tell your supervisor.**
- If you think there is a problem with your dust control equipment, ensure additional control measures are taken to reduce exposure to respirable crystalline silica while the problem persists.**
- Even if it is not normally necessary for you to wear a dust mask, it may be necessary for you to wear one temporarily in the event of a spillage or if other control measures fail.**
- Clear up spills straight away. Use vacuum or wet cleaning methods.**
- Use, maintain and store any respiratory protective equipment provided in accordance with instructions.**
- Use handling aids when available.**

Spray drying - ceramics

This activity relates to spray drying of materials containing crystalline silica as a process step to prepare raw materials for shaping

This guidance sheet is aimed at employers to help them comply with the requirements of workplace health and safety legislation, by controlling exposure to respirable crystalline silica.

Specifically, this sheet provides good practice advice on dust control during spray drying medium and large quantities of materials containing crystalline silica. Following the key points of this task sheet will help reduce exposure. Depending on the specific circumstances of each case, it may not be necessary to apply all of the control measures identified in this sheet in order to minimize exposure to respirable crystalline silica. i.e. to apply appropriate protection and prevention measures.

This document should also be made available to persons who may be exposed to respirable crystalline silica in the workplace, in order that they may make the best use of the control measures which are implemented.

This sheet forms part of the Good Practices Document on silica dust prevention, which is aimed specifically at the control of personal exposure to respirable crystalline silica dust in the workplace.

Access

- ✓ Restrict access to the working area to authorised personnel only.
- ✓ The work area and equipment should be clearly labelled.

Design and equipment

- ✓ Design the feed and discharge to and from the drying chamber through pipes rather than a loading door.
- ✓ Use discharge containers with lids for spray dried materials.
- ✓ Apply good thermal insulation.
- ✓ Lights/signs should clearly indicate when the dryer is in use
- ✓ Use a heat reclamation and air filtration system in conjunction with the dryer
- ✓ Air throughput should be via a negative pressure fan
- ✓ Consider the need for explosion relief if using direct heating (burners with gas or oil).
- ✓ Design closed system to allow easy access for cleaning and maintenance.
- ✓ Keep the process equipment under negative pressure to prevent leaks.
- ✓ Discharge extracted air to a safe place away from doors, windows and air inlets.



Maintenance

- ✓ Ensure equipment used in the task is maintained as advised by the supplier/installer in efficient working order and in good repair.
- ✓ Adopt a “permit to work” system for maintenance work.
- ✓ Replace consumables (filters etc.) in accordance with the manufacturer’s recommendations.

Examination and testing

- ✓ Obtain information on the design performance of the ventilation equipment from the supplier. Keep this information to compare with future test results.
- ✓ Visually check all equipment at least once per week for signs of damage or, if it is in constant use, check it more frequently. If used infrequently, then check it before each use.
- ✓ Have the ventilation equipment examined and tested against its performance standard, at least once each year.
- ✓ Keep records of inspections for a suitable period of time which complies with national laws (minimum five years).

Cleaning and housekeeping

- ✓ Clean your workplace and equipment on a regular basis.
- ✓ Deal with spills immediately.
- ✓ Use vacuum or wet cleaning methods.
- X Do not clean up with a dry brush or using compressed air.**

Personal Protective Equipment

- ✓ Refer to task sheet 2.1.15 dedicated to Personal Protective Equipment.
- ✓ Risk assessment must be carried out to determine whether existing controls are adequate. If necessary, respiratory protective equipment (with the appropriate protection factor) should be provided and worn.
- ✓ Provide storage facilities to keep personal protective equipment clean, when not in use.
- ✓ Replace personal protective equipment at intervals recommended by the manufacturer/supplier.

Training

- ✓ Give your employees information on the health effects associated with respirable crystalline silica dust.
- ✓ Provide employees with training on: dust exposure prevention; checking controls are working and using them; when and how to use any respiratory protective equipment provided and what to do if something goes wrong. Refer to task sheet 2.1.19 and part 1 of the Good Practice Guide.

Supervision

- ✓ Have a system to check that control measures are in place and that they are being followed. Refer to task sheet 2.1.17.
- ✓ Employers should make sure that employees have all the means to perform the checklist given opposite.

Employee checklist for making the best use of the controls

- Before use, check that the seals are intact.
- Make sure the ventilation system is switched on and is working.
- Look for signs of leaks, wear or damage of any equipment used. If you find any problems, tell your supervisor.
- If you think there is a problem with your dust control equipment, ensure additional control measures are taken to reduce exposure to respirable crystalline silica dust while the problem persists.
- Put lids on containers immediately after use.
- Clear up spills immediately. Use vacuum cleaning or wet cleaning methods for solids. For liquids, contain or absorb with granules or mats. Dispose of spills safely
- Do not clean up with a dry brush or using compressed air.
- Use, maintain and store any respiratory protective equipment provided in accordance with instructions.
- Follow any special procedures that are needed before the system is opened or entered, e.g. purging and washing.

2.2.33

Spray glazing - Ceramics

This activity relates to the automatic or manual spray glazing of ceramic products with glazes containing crystalline silica.

This guidance sheet is aimed at employers to help them comply with the requirements of workplace health and safety legislation, by controlling exposure to respirable crystalline silica.

Specifically, this sheet provides good practice advice on dust control during spray glazing of ceramic products with glazes containing crystalline silica. Following the key points of this task sheet will help reduce exposure. Depending on the specific circumstances of each case, it may not be necessary to apply all of the control measures identified in this sheet in order to minimize exposure to respirable crystalline silica.
i.e. to apply appropriate protection and prevention measures.

This document should also be made available to persons who may be exposed to respirable crystalline silica in the workplace, in order that they may make the best use of the control measures which are implemented.

This sheet forms part of the Good Practices Document on silica dust prevention, which is aimed specifically at the control of personal exposure to respirable crystalline silica dust in the workplace.

Access

- ✓ Restrict access to the working area to authorised personnel only.

Design and equipment

- ✓ If possible, enclose the work area fully.
- ✓ Make the enclosure deep enough to contain equipment and materials.
- ✓ The airflow at the face of the enclosure should be at least 1 m/s. Refer to task sheet 2.1.13.
- ✓ Keep the open area as small as possible while allowing enough room for safe working.
- ✓ Provide a turntable to make it easier to cover all surfaces and the operator does not need to spray against the airflow
- ✗ Do not store items inside the ventilated area; they will obstruct the airflow. Ensure large items do not obstruct the work opening.
- ✓ Use filters to avoid glaze deposits on electric motors, fan blades and ventilation ducts.
- ✓ If possible, provide a water spray system, to absorb overspray of glaze and put it to a reservoir
- ✓ Where possible, locate the work area away from doors, windows and walkways to stop draughts interfering with the ventilation and spreading dust.
- ✓ Provide an air supply to the workroom to replace extracted air.
- ✓ Provide an easy way of checking the control is working, e.g. a manometer, pressure gauge or tell-tale (a small flag).
- ✓ Discharge extracted air to a safe place away from doors, windows and air inlets.
- ✗ **Air re-circulation is not recommended.**

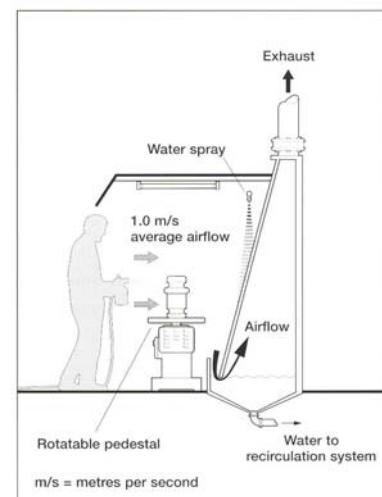

Maintenance

- ✓ Ensure equipment used in the task is maintained as advised by the supplier/installer in efficient working order and in good repair.

Replace consumables (filters etc.) in accordance with the manufacturer's recommendations.

Examination and testing

- ✓ Obtain information on the design performance of the ventilation equipment from the supplier. Keep this information to compare with future test results.
- ✓ Visually check all equipment at least once per week for signs of damage or, if it is in constant use, check it more frequently. If used infrequently, then check it before each use.
- ✓ Have the ventilation equipment examined and tested against its performance standard, at least once each year.
- ✓ Keep records of inspections for a suitable period of time which complies with national laws (minimum five years).

Cleaning and housekeeping

- ✓ Clean your workplace and equipment on a regular basis.
- ✓ Deal with spills immediately.
- ✓ Use vacuum or wet cleaning methods.
- ✗ **Do not clean up with a dry brush or using compressed air.**
- ✓ Store containers in a safe place and dispose of empty containers safely.

Personal Protective Equipment

- ✓ Refer to task sheet 2.1.15 dedicated to Personal Protective Equipment.
- ✓ Risk assessment must be carried out to determine whether existing controls are adequate. If necessary, respiratory protective equipment (with the appropriate protection factor) should be provided and worn.
- ✓ Provide storage facilities to keep personal protective equipment clean, when not in use.
- ✓ Replace personal protective equipment at intervals recommended by the manufacturer/supplier.

Training

- ✓ Give your employees information on the health effects associated with respirable crystalline silica dust.
- ✓ Provide employees with training on: dust exposure prevention; checking controls are working and using them; when and how to use any respiratory protective equipment provided and what to do if something goes wrong. Refer to task sheet 2.1.19 and part 1 of the Good Practice Guide.

Supervision

- ✓ Have a system to check that control measures are in place and that they are being followed. Refer to task sheet 2.1.17.
- ✓ Employers should make sure that employees have all the means to perform the checklist given opposite.

Employee checklist for making the best use of the controls

- Make sure the ventilation system is switched on and is working.**
- Make sure it is running properly; check the manometer, pressure gauge or tell-tale.**
- Look for signs of damage, wear or poor operation of any equipment used. If you find any problems, tell your supervisor.**
- If you think there is a problem with your dust control equipment, ensure additional control measures are taken to reduce exposure to respirable crystalline silica dust while the problem persists.**
- Make sure that paper bags and other waste material aren't drawn into the ventilation duct.**
- Make sure that large items do not obstruct the working opening.**
- Remove broken products immediately from the work area.**
- Put lids on containers immediately after use.**
- Clear up spills immediately. Use vacuum cleaning or wet cleaning methods for solids. For liquids. Contain or absorb with granules or mats or wash away with a lot of water. Dispose of spills safely[^].**
- Do not clean up with a dry brush or using compressed air.**
- Use, maintain and store any respiratory protective equipment provided in accordance with instructions.**

Transport systems for fine dry silica products

This activity relates to the design of the transport systems for fine dry silica products.

This guidance sheet is aimed at employers to help them comply with the requirements of workplace health and safety legislation, by controlling exposure to respirable crystalline silica.

Specifically, this sheet provides advice on the design of transport systems for silica flour products. Following the key points of this task sheet will help reduce exposure. Depending on the specific circumstances of each case, it may not be necessary to apply all of the control measures identified in this sheet in order to minimize exposure to respirable crystalline silica. i.e. to apply appropriate protection and prevention measures.

This document should also be made available to persons who may be exposed to respirable crystalline silica in the workplace, in order that they may make the best use of the control measures which are implemented.

This sheet forms part of the Good Practices Guide on silica dust prevention, which is aimed specifically at the control of personal exposure to respirable crystalline silica dust in the workplace.

Access

- ✓ Restrict access to the work area to authorised personnel only.

Design and equipment

- ✓ It is preferable to use enclosed handling systems when transporting silica flour.
- ✓ **Pneumatic systems** are appropriate for both horizontal and vertical transport of silica flour.
- ✓ For horizontal transport in **pneumatic systems**, pipes should be angled downwards where possible to prevent flour settling in the pipes and causing a blockage in the event system pressure is lost.
- ✓ The pipe work in **pneumatic systems** should be designed to minimise unnecessary obstacles and to minimise sharp bends. Pipe connections should be properly sealed.
- ✓ For **air slides**, the fluidising air will be drawn away by the dust extraction system. For this reason, air slides cannot be used if the product is too fine. If the surface area is more than 10,000 cm²/g, use screw conveyors. More than one de-dusting connection may be required on long lengths in order to correctly balance airflows.
- ✓ **Air slides** should be inclined slightly in order to assist the horizontal transport of silica flour. The quality of the cloth used in air slides should be selected to avoid excessive pressure loss for the fan, whilst also preventing silica flour from falling through the cloth and causing it to become blocked.
- ✓ For **screw conveyors**, the screw must be enclosed. Specialist design is required due to the abrasive properties of silica flour (contact an experienced supplier).
- ✓ **Screw conveyors** may need to be equipped with dust extraction systems unless they are connected to equipment that already operates under negative pressure. Refer to task sheet 2.1.13.
- × **Conveyor belts** are not suitable for the transportation of loose silica flour. However, they may be used for the transport of other, coarser, materials and in machinery that handles bags of silica flour. Conveyors handling bags of silica flour, or other dusty materials, should be enclosed and equipped with dust extraction.
- ✓ **Elevators** are suitable for vertical transport, provided they are fully enclosed. Dust extraction systems may be required unless elevators are connected to equipment that already operates under negative pressure.
- ✓ It may be necessary to apply fluidising air at the base of **silos** holding silica flour. Such systems should be designed so that the fluidising air is only applied at times when it is necessary to make the silica flour flow out of the silo. Fluidising air should not be left switched on permanently in situations where the air could migrate and cause silica flour to be emitted under pressure from elsewhere in the system.

Maintenance

- ✓ Ensure equipment used in the task and building are maintained as advised by the supplier/installer in efficient working order and in good repair.
- ✓ Replace consumables (filters etc) in accordance with the manufacturer's recommendations.

Examination and testing

- ✓ Visually check the cleaning equipment for signs of damage at least once per week or, if it is in constant use, check it more frequently. If used infrequently, then check it before each use.
- ✓ Obtain information on the design performance of dust suppression and/or extraction equipment from the supplier. Keep this information to compare with future test results.
- ✓ Keep records of inspections for a suitable period of time which complies with national laws (minimum five years).

Cleaning and housekeeping

- ✓ Clean your workplace on a regular basis.
- ✗ **Do not clean up with a dry brush or using compressed air.**
- ✓ Use vacuum or wet cleaning methods.

Personal Protective Equipment

- ✓ Refer to task sheet 2.1.15 dedicated to Personal Protective Equipment.
- ✓ Provide pictograms on doors to indicate areas where respiratory protective equipment must be worn.
- ✓ Provide storage facilities to keep personal protective equipment clean when not in use.
- ✓ Provide enough places where Personal protective equipment can be found (e.g. box with disposable dust masks). Indicate those places with pictograms.

Training

- ✓ Give your employees information on the health effects associated with respirable crystalline silica dust
- ✓ Provide employees with training on: dust exposure prevention; checking controls are working and using them; when and how to use any respiratory protective equipment provided and what to do if something goes wrong. Refer to task sheet 2.1.19 and part 1 of the Good Practice Guide.

Supervision

- ✓ Have a system to check that control measures are in place and that they are being followed. Refer to task sheet 2.1.17.
- ✓ Employers should make sure that employees have all the means to perform the checklist given opposite.

Employee checklist for making the best use of the controls

- ☐ **Look for signs of damage or wear of building parts and of your work equipment. If you find any problems, tell your supervisor.**
- ☐ **Problems with silica flour transportation systems may be indicated by emissions of dust into the workplace air and by the appearance of piles of silica flour on floors and surfaces. Report any of these to your supervisor.**
- ☐ **If you think there is a problem with your dust control equipment, ensure additional control measures are taken to reduce exposure to respirable crystalline silica dust while the problem persists.**
- ☐ **Clear up spills straight away. Use vacuum cleaning or wet mopping. Dispose of spills safely.**
- ☐ **Clean up control cabins using vacuum or wet cleaning methods.**
- ☐ **Use, maintain and store any respiratory protective equipment provided in accordance with instructions.**

2.2.35

Use of a drilling rig

This activity covers drilling operations into rocks or strata containing crystalline silica.

Drilling may be carried out for exploratory or reserve assessment purposes, or as part of the minerals extraction process

This guidance sheet is aimed at employers to help them comply with the requirements of workplace health and safety legislation, by controlling exposure to respirable crystalline silica.

Specifically, this sheet provides advice on dust control during the use of a drilling rig in hard rock quarries. Following the key points of this task sheet will help reduce exposure.

Depending on the specific circumstances of each case, it may not be necessary to apply all of the control measures identified in this sheet in order to minimize exposure to respirable crystalline silica. i.e. to apply appropriate protection and prevention measures.

This document should also be made available to persons who may be exposed to respirable crystalline silica in the workplace, in order that they may make the best use of the control measures which are implemented.

This sheet forms part of the Good Practices Guide on silica dust prevention, which is aimed specifically at the control of personal exposure to respirable crystalline silica in the workplace.

Access

- ✓ Restrict access to the work area to authorised personnel only.

Design and equipment

- ✓ Dust control can be achieved using water fed into the compressed air supply, thereby suppressing the dust. Additives may need to be used for lubrication.
- ✓ Ensure that water supplies are adequate and that they are maintained. Take extra precautions during cold weather to protect against freezing.
- ✓ The use of a foaming agent for dust suppression is also possible.
- ✓ Alternatively, dust control may be achieved by extraction of the dry dust using local exhaust ventilation, connected to a suitable dust extraction system (e.g. a bag filter/cyclone), or by using spray mist dust suppression. Refer to task sheet 2.1.13.
- ✓ Drilling equipment with an integral control cabin or remote control facility with closed doors and windows may be used to isolate personnel from dust sources.
- ✓ Control cabins can be fitted with forced air filtration or full air conditioning.



Maintenance

- ✓ Ensure equipment used in the task is maintained as advised by the supplier/installer in efficient working order and in good repair.
- ✓ Replace consumables (filters etc) in accordance with the manufacturer's recommendations.
- ✓ It is preferable that all maintenance functions that could be done in a workshop be done in a workshop.

Examination and testing

- ✓ Visually check the equipment at least once per week for signs of damage or, if it is in constant use, check it more frequently. If used infrequently, then check it before each use.
- ✓ Obtain information on the design performance of the dust suppression and/or extraction equipment from the supplier. Keep this information to compare with future test results.
- ✓ Keep records of inspections for a suitable period of time which complies with national laws (minimum five years).

Cleaning and housekeeping

- ✓ Clean your workplace on a regular basis.
- ✗ **Do not clean up with a dry brush or using compressed air.**
- ✓ Use vacuum or wet cleaning methods.

Personal Protective Equipment

- ✓ Refer to task sheet 2.1.15 dedicated to Personal Protective Equipment.
- ✓ Risk assessment must be carried out to determine whether existing controls are adequate. If necessary, respiratory protective equipment (with the appropriate protection factor) should be provided and worn.
- ✓ Provide storage facilities to keep personal protective equipment clean when not in use.
- ✓ Replace respiratory protective equipment at intervals recommended by its suppliers.

Training

- ✓ Give your employees information on the health effects associated with respirable crystalline silica dust
- ✓ Provide employees with training on: dust exposure prevention; checking controls are working and using them; when and how to use any respiratory protective equipment provided and what to do if something goes wrong. Refer to task sheet 2.1.19 and part 1 of the Good Practice Guide.

Supervision

- ✓ Have a system to check that control measures are in place and that they are being followed. Refer to task sheet 2.1.17.
- ✓ Employers should make sure that employees have all the means to perform the checklist given opposite.

Employee checklist for making the best use of the controls

- ☐ **For wet dust suppression methods, make sure the water supply is working before starting the drilling equipment**
- ☐ **For dry dust collection methods, make sure the dust extraction system is switched on and is working**
- ☐ **Look for signs of damage, wear or poor operation of any equipment used. If you find any problems, tell your supervisor.**
- ☐ **If you think there is a problem with your dust control equipment, ensure additional control measures are taken to reduce exposure to respirable crystalline silica while the problem persists.**
- ☐ **Clean up any control cabin using vacuum or wet cleaning methods.**
- ☐ **Use, maintain and store any respiratory protective equipment provided in accordance with instructions.**

Water Assisted Dust Suppression

This activity relates to the use of water flooding and of atomised water mists to suppress the generation and lower the concentration of airborne crystalline silica dusts

This guidance sheet is aimed at employers to help them comply with the requirements of workplace health and safety legislation, by controlling exposure to respirable crystalline silica.

Specifically, this sheet provides good practice advice on dust control by using water flooding and atomized water mists. Following the key points of this task sheet will help reduce exposure. Depending on the specific circumstances of each case, it may not be necessary to apply all of the control measures identified in this sheet in order to minimize exposure to respirable crystalline silica.

i.e. to apply appropriate protection and prevention measures.

This document should also be made available to persons who may be exposed to respirable crystalline silica in the workplace, in order that they may make the best use of the control measures which are implemented.

This sheet forms part of the Good Practices Document on silica dust prevention, which is aimed specifically at the control of personal exposure to respirable crystalline silica dust in the workplace.

Access

- ✓ Restrict access to the work area to authorised personnel only.

Design and equipment

- ✓ If possible, use water fed tools for cutting, grinding and shaping crystalline silica containing products.
- ✓ Consider the application of water sprays or trickles to working surfaces when water fed tools are not available.
- ✓ In circumstances where there will be no adverse impact on process conditions, product quality or health and safety, apply water mists in work areas where airborne crystalline silica may be generated by material and product handling.
- ✓ Ensure electrical systems have adequate protection when used with water flooding, spraying or misting.
- ✓ Take precautions to ensure the control of legionella and other biological agents in water storage and delivery systems.
- ✓ Take precautions to ensure that wastewater and sludges are disposed according to appropriate prescriptions.



Maintenance

- ✓ Ensure water dust suppression equipment used in the task is maintained as advised by the supplier/ installer in efficient working order and good repair.
- ✓ Replace consumables in accordance with the manufacturer's recommendations.

Examination and testing

- ✓ Visually check all equipment for signs of damage at least once per week or, if it is in constant use, check it more frequently. If used infrequently, then check it before each use.
- ✓ Obtain information on the design performance of dust suppression equipment from the supplier. Keep this information to compare with future test results.
- ✓ Keep records of inspections for a suitable period of time which complies with national laws (minimum five years).

Cleaning and housekeeping

- ✓ Clean water dust suppression equipment as instructed by the manufacturer/supplier.
- ✓ Avoid accumulation of slurries/sludges.
- ✓ Ensure spills are cleaned up immediately, and provide adequate spill control equipment.
- X Do not allow collected slurries/sludges to dry out and the dust to become airborne.**

Personal Protective Equipment

- ✓ Refer to task sheet 2.1.15 dedicated to Personal Protective Equipment.
- ✓ Risk assessment must be carried out to determine areas where personal protective equipment must be used. If necessary, respiratory protective equipment (with the appropriate protection factor) should be provided and worn.
- ✓ Provide storage facilities to keep personal protective equipment clean, when not in use.
- ✓ Replace personal protective equipment at intervals recommended by the manufacturer/supplier.

Training

- ✓ Give your employees information on the health effects associated with respirable crystalline silica dust.
- ✓ Provide employees with training on: dust exposure prevention; checking controls are working and using them; when and how to use any respiratory protective equipment provided and what to do if something goes wrong. Refer to task sheet 2.1.19 and part 1 of the Good Practice Guide.

Supervision

- ✓ Have a system to check that control measures are in place and that they are being followed. Refer to task sheet 2.1.17.
- ✓ Employers should make sure that employees have all the means to perform the checklist given opposite.

Employee checklist for making the best use of the controls

- Make sure that water dust suppression equipment is working properly.**
- Ensure water supplies are adequate with an uninterrupted supply during use for dust suppression.**
- Protect water supplies against freezing.**
- Look for signs of damage or malfunction, and if you find any tell your supervisor immediately.**
- Clean up spills immediately.**
- Clean dust suppression equipment regularly and after use.**
- Keep personal protective equipment clean and properly stored.**